

FOR M11
CH7011

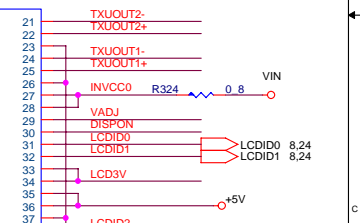

ST2	ST1	ST0	FSB Frequency	Memory Frequency	FX Core Clock - Low	FX Core Clock - High
*	0	0	400MHz	266MHz	1.33MHz	200MHz
0	0	1	400MHz	200MHz	1.00MHz	200MHz
0	1	0	400MHz	200MHz	1.00MHz	1.33MHz
0	1	1	400MHz	266MHz	1.33MHz	266MHz
1	0	0	533MHz	266MHz	1.33MHz	200MHz
1	0	1	533MHz	266MHz	1.33MHz	266MHz
1	1	0	533MHz	333MHz	1.66MHz	266MHz
1	1	1	400MHz	333MHz	1.66MHz	250MHz

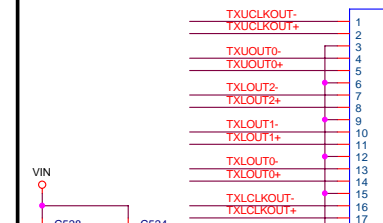
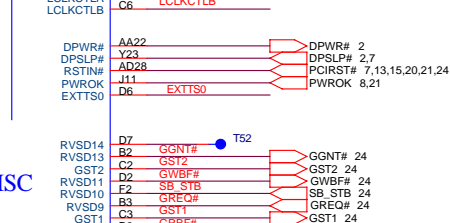
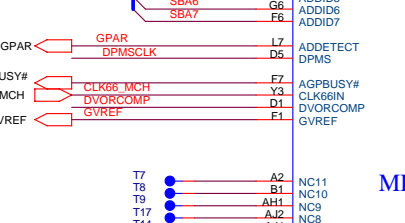
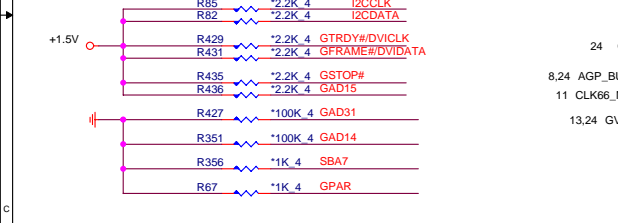
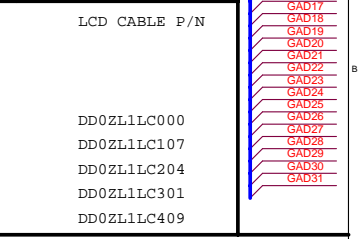
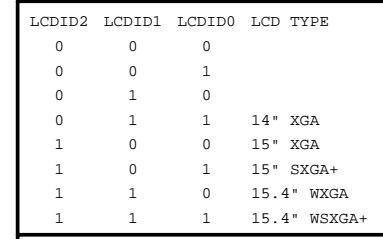
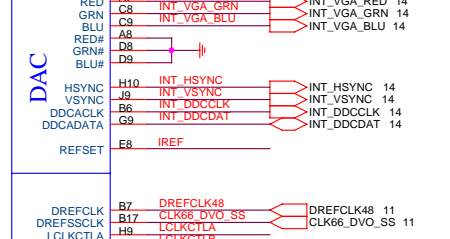
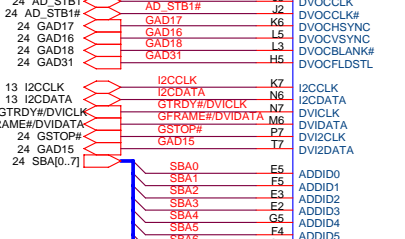
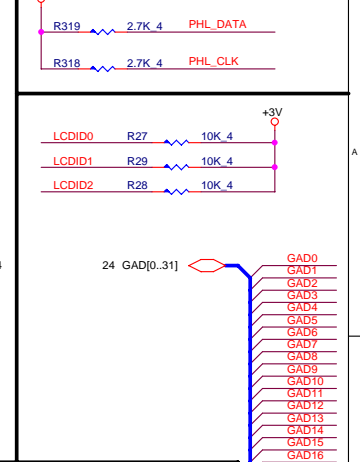
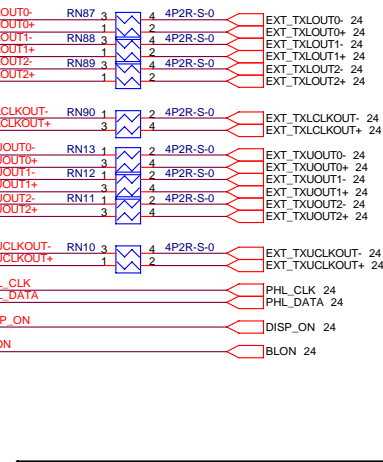
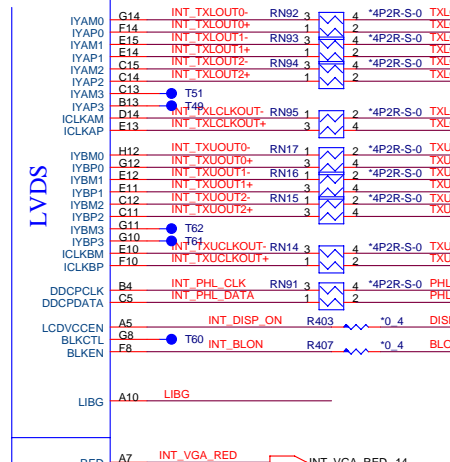
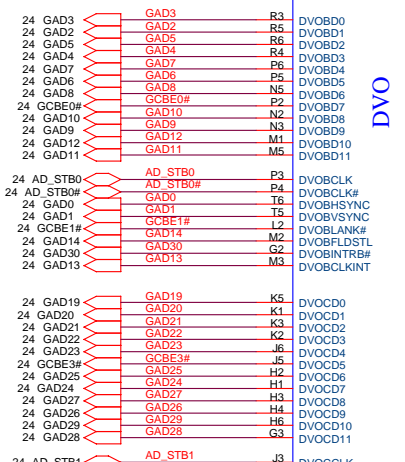
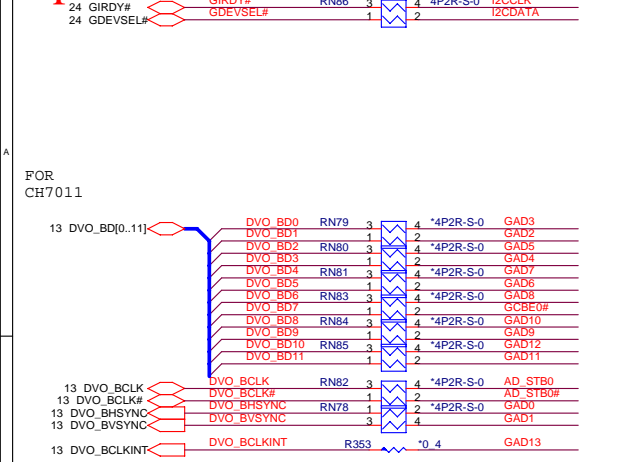
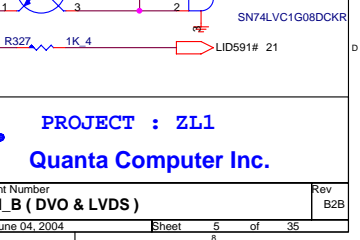
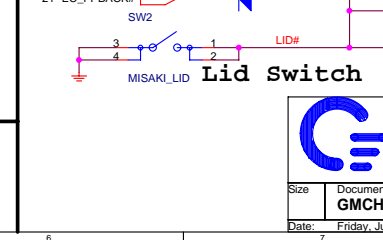
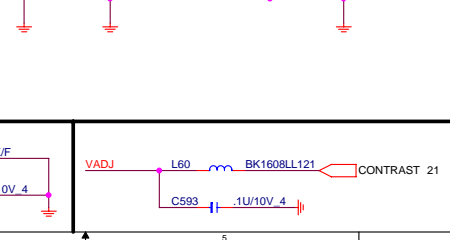
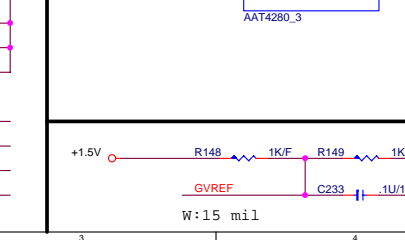
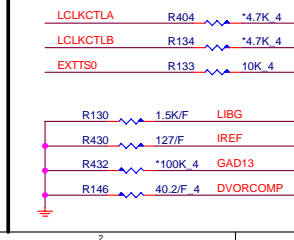
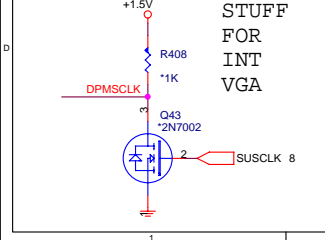
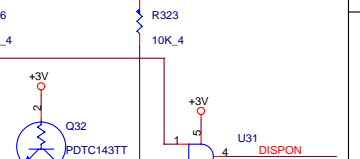
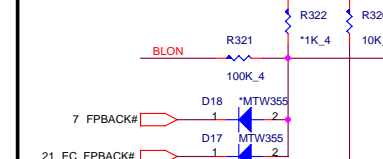
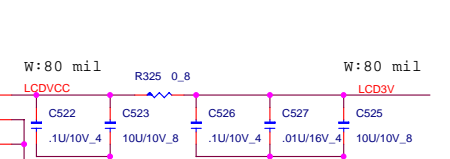
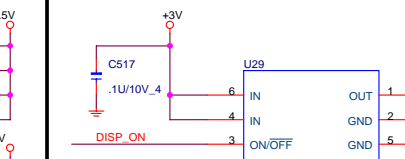
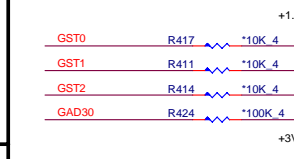
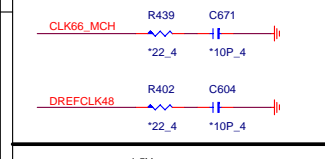

LCDID2	LCDID1	LCDID0	LCD TYPE	LCD CABLE P/N
0	0	0		
0	0	1		
0	1	0	14" XGA	DD0ZL1LC000
0	1	1	15" XGA	DD0ZL1LC107
1	0	1	15" SXGA+	DD0ZL1LC204
1	1	0	15.4" WXGA	DD0ZL1LC301
1	1	1	15.4" WSXGA+	DD0ZL1LC409

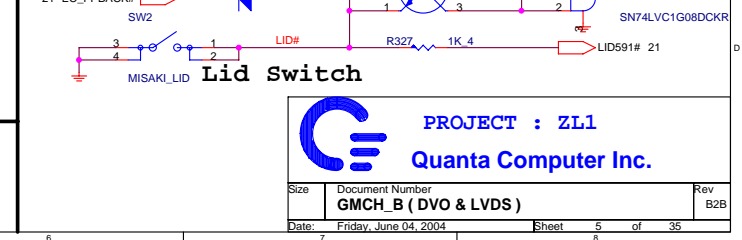
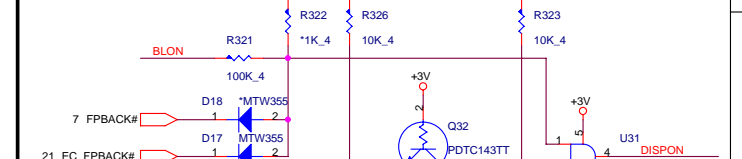
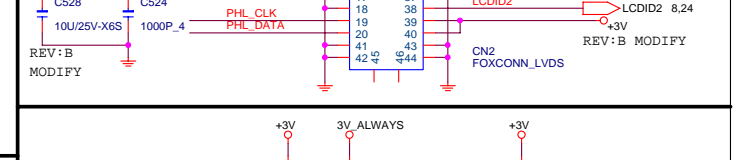
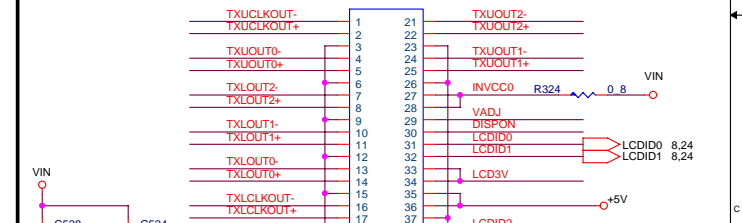

PROJECT : ZL1
Quanta Computer Inc.

Size: Document Number: Rev: B2B
 Date: Friday, June 04, 2004 Sheet 5 of 35

U15D

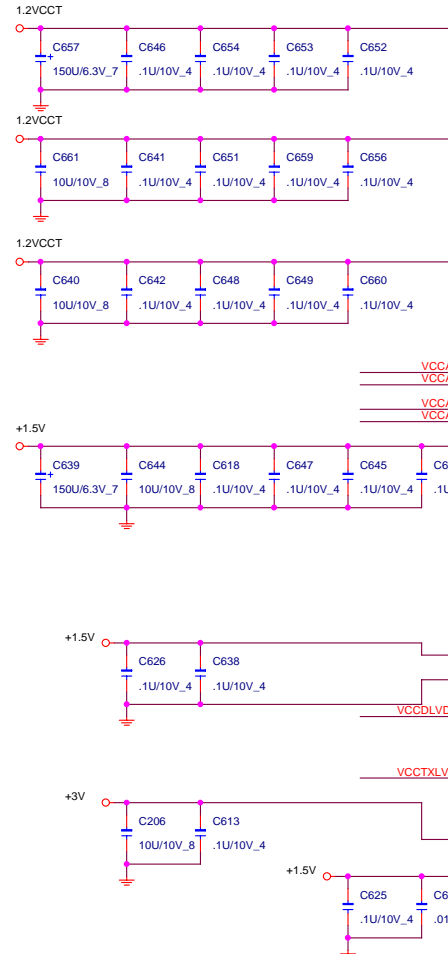

POWER

W21	VCC0
AA19	VCC1
AA17	VCC2
T17	VCC3
P17	VCC4
U16	VCC5
R16	VCC6
N16	VCC7
AA15	VCC8
T15	VCC9
P15	VCC10
J15	VCC11
U14	VCC12
R14	VCC13
H14	VCC14
H14	VCC15
T13	VCC16
P13	VCC17
V9	VCCCH0
W8	VCCCH1
J8	VCCCH2
Y7	VCCCH3
U6	VCCCH4
W5	VCCCH5
Y1	VCCCH6
V1	VCCCH7
D29	VCCAHPLL
Y2	VCCAGPLL
A6	VCCADPLLA
B16	VCCADPLLB
P9	VCCDVO0
M9	VCCDVO1
K9	VCCDVO2
R8	VCCDVO3
U8	VCCDVO4
M8	VCCDVO5
L8	VCCDVO6
J8	VCCDVO7
H7	VCCDVO8
E6	VCCDVO9
M4	VCCDVO10
J4	VCCDVO11
E4	VCCDVO12
N1	VCCDVO13
J1	VCCDVO14
E1	VCCDVO15
B9	VCCADAC0
A9	VCCADAC1
B8	VSSADAC
B15	VCCDLVDS0
B14	VCCDLVDS1
J13	VCCDLVDS2
G13	VCCDLVDS3
A12	VCCTXLVD0
D10	VCCTXLVD1
D10	VCCTXLVD2
F9	VCCTXLVD3
A4	VCCPI00
A3	VCCPI01
A11	VCCALVDS
B11	VSSALVDS

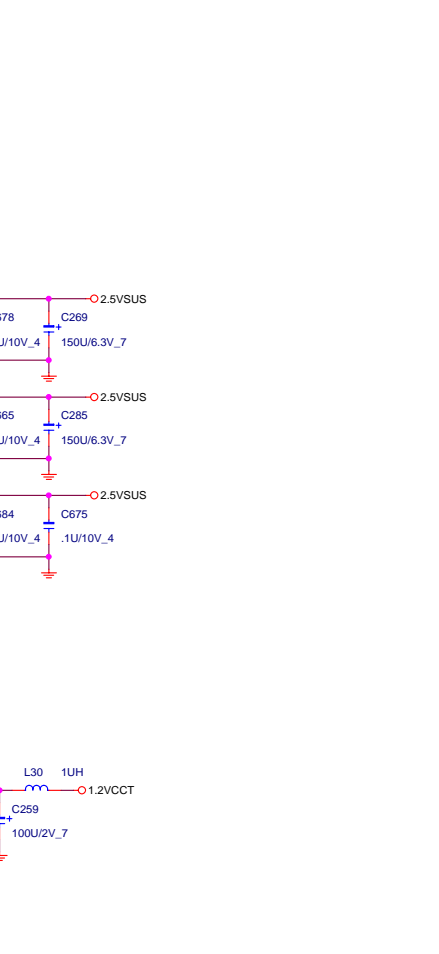
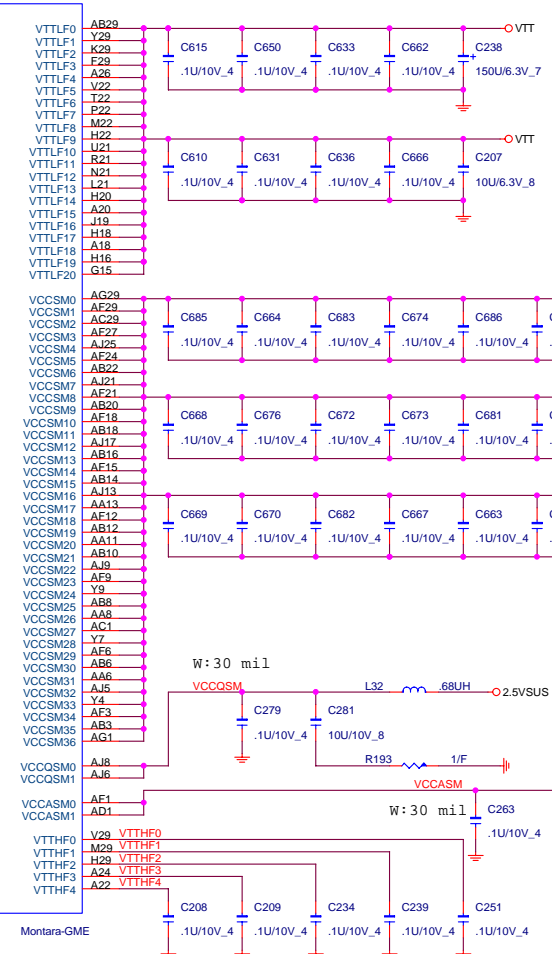

VSS

AA29	VSS0	VSS91	P16
W29	VSS1	VSS92	J16
U29	VSS2	VSS93	F16
N29	VSS3	VSS94	AC15
L29	VSS4	VSS95	AB15
J29	VSS5	VSS96	U15
G29	VSS6	VSS97	R15
E29	VSS7	VSS98	N15
C29	VSS8	VSS99	D15
AE28	VSS100	VSS101	H15
AC28	VSS102	VSS103	AA14
E28	VSS104	VSS105	T14
D28	VSS106	VSS107	P14
AJ27	VSS108	VSS109	J14
AG27	VSS110	VSS111	F14
AC27	VSS112	VSS113	AE13
F27	VSS114	VSS115	AB13
VSS16	VSS116	VSS117	U13
VSS17	VSS118	VSS119	R13
AJ26	VSS120	VSS121	H13
AB26	VSS122	VSS123	D13
W26	VSS124	VSS125	F13
J26	VSS126	VSS127	H13
R26	VSS128	VSS129	D13
N26	VSS130	VSS131	A13
L26	VSS132	VSS133	AE12
J26	VSS134	VSS135	AG12
G26	VSS136	VSS137	AA12
AE25	VSS138	VSS139	J12
AA25	VSS140	VSS141	AJ11
D25	VSS142	VSS143	AC11
A25	VSS144	VSS145	AB11
AG24	VSS146	VSS147	H11
AA24	VSS148	VSS149	F11
V24	VSS150	VSS151	D11
T24	VSS152	VSS153	AJ10
P24	VSS154	VSS155	AE10
M24	VSS156	VSS157	AA10
K24	VSS158	VSS159	AJ10
H24	VSS160	VSS161	C10
F24	VSS162	VSS163	AG9
B24	VSS164	VSS165	AB9
AJ23	VSS166	VSS167	W9
AC23	VSS168	VSS169	U9
AA23	VSS170	VSS171	T9
D23	VSS172	VSS173	R9
A23	VSS174	VSS175	N9
AG22	VSS176	VSS177	L9
AE22	VSS178	VSS179	E9
W22	VSS180	VSS181	AC8
R22	VSS182	VSS183	Y8
VSS140	VSS184	VSS185	V8
N22	VSS186	VSS187	V8
L22	VSS188	VSS189	T8
J22	VSS190	VSS191	P8
F22	VSS192	VSS193	K8
C22	VSS194	VSS195	H8
AG21	VSS196	VSS197	AJ7
AB21	VSS198	VSS199	AE7
AA21	VSS200	VSS201	AB7
Y21	VSS202	VSS203	R7
V21	VSS204	VSS205	M7
T21	VSS206	VSS207	J7
P21	VSS208	VSS209	G7
M21	VSS210	VSS211	E7
H21	VSS212	VSS213	C7
D21	VSS214	VSS215	AC6
A21	VSS216	VSS217	Y6
AJ20	VSS218	VSS219	L6
AC20	VSS220	VSS221	Y6
AA20	VSS222	VSS223	U6
J20	VSS224	VSS225	B6
AE19	VSS226	VSS227	AE4
AB19	VSS228	VSS229	AC4
H19	VSS230	VSS231	AA4
D19	VSS232	VSS233	W4
A19	VSS234	VSS235	T4
AJ18	VSS236	VSS237	N4
AG18	VSS238	VSS239	K4
AA18	VSS240	VSS241	G4
J18	VSS242	VSS243	D4
E18	VSS244	VSS245	AJ3
AC17	VSS246	VSS247	AG3
AB17	VSS248	VSS249	R2
U17	VSS250	VSS251	AJ1
R17	VSS252	VSS253	AE1
N17	VSS254	VSS255	AA1
H17	VSS256	VSS257	U1
D17	VSS258	VSS259	L1
A17	VSS260	VSS261	C1
AE16	VSS262	VSS263	F20
AA16	VSS264	VSS265	
T16	VSS266	VSS267	

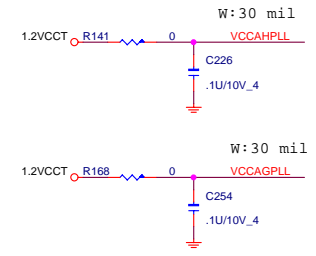
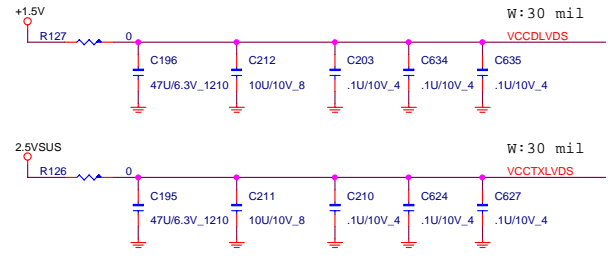
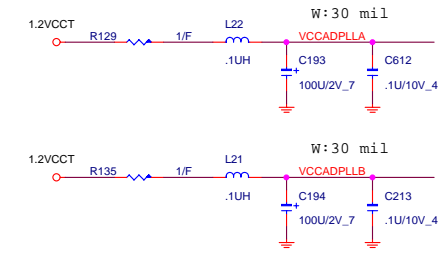

PROJECT : ZL1
Quanta Computer Inc.

Size	Document Number	Rev
	GMCH_C (POWER)	A1A
Date:	Friday, June 04, 2004	Sheet 6 of 35

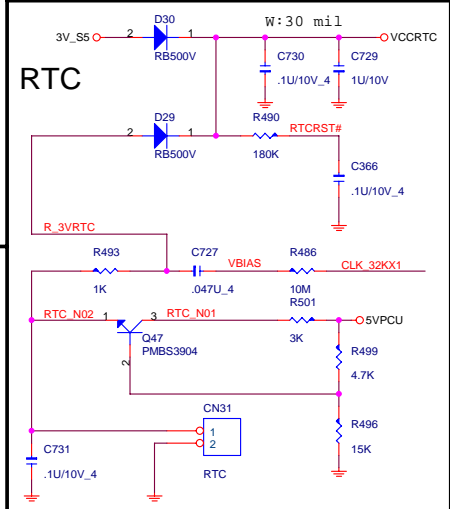
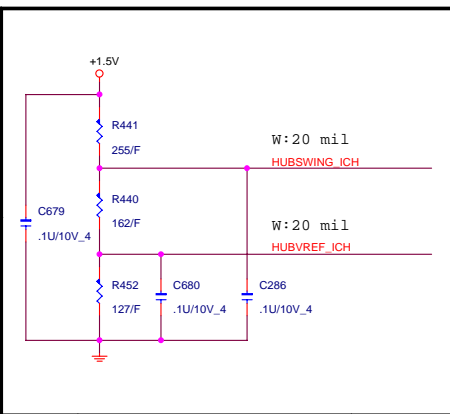
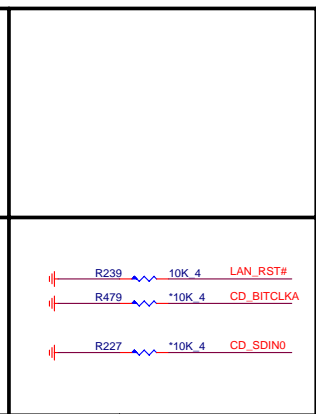
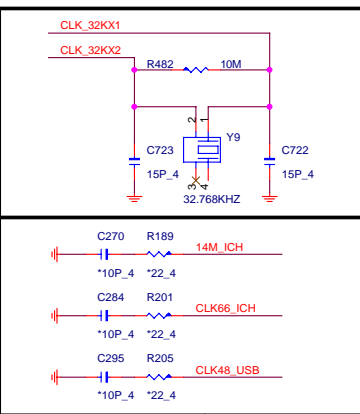
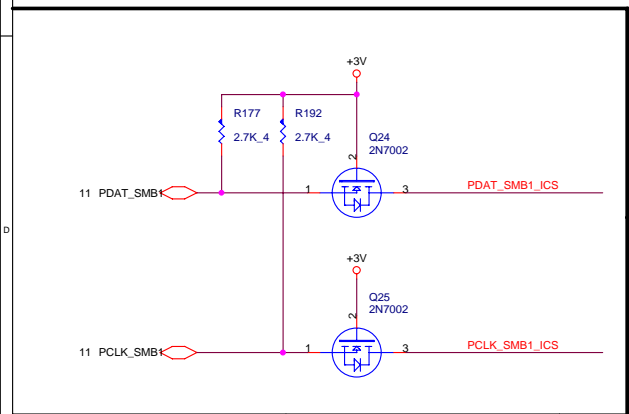
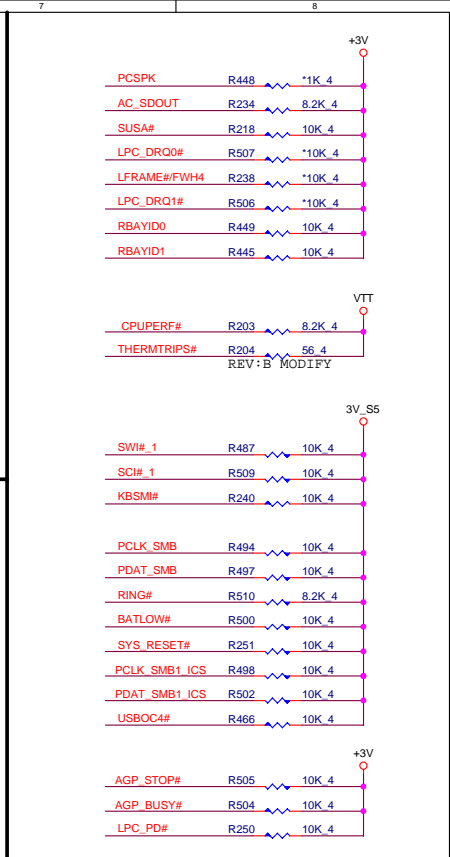
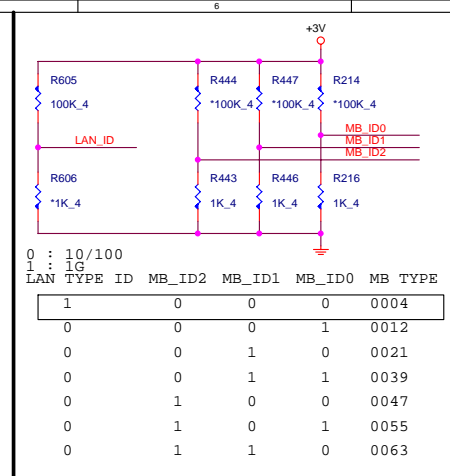
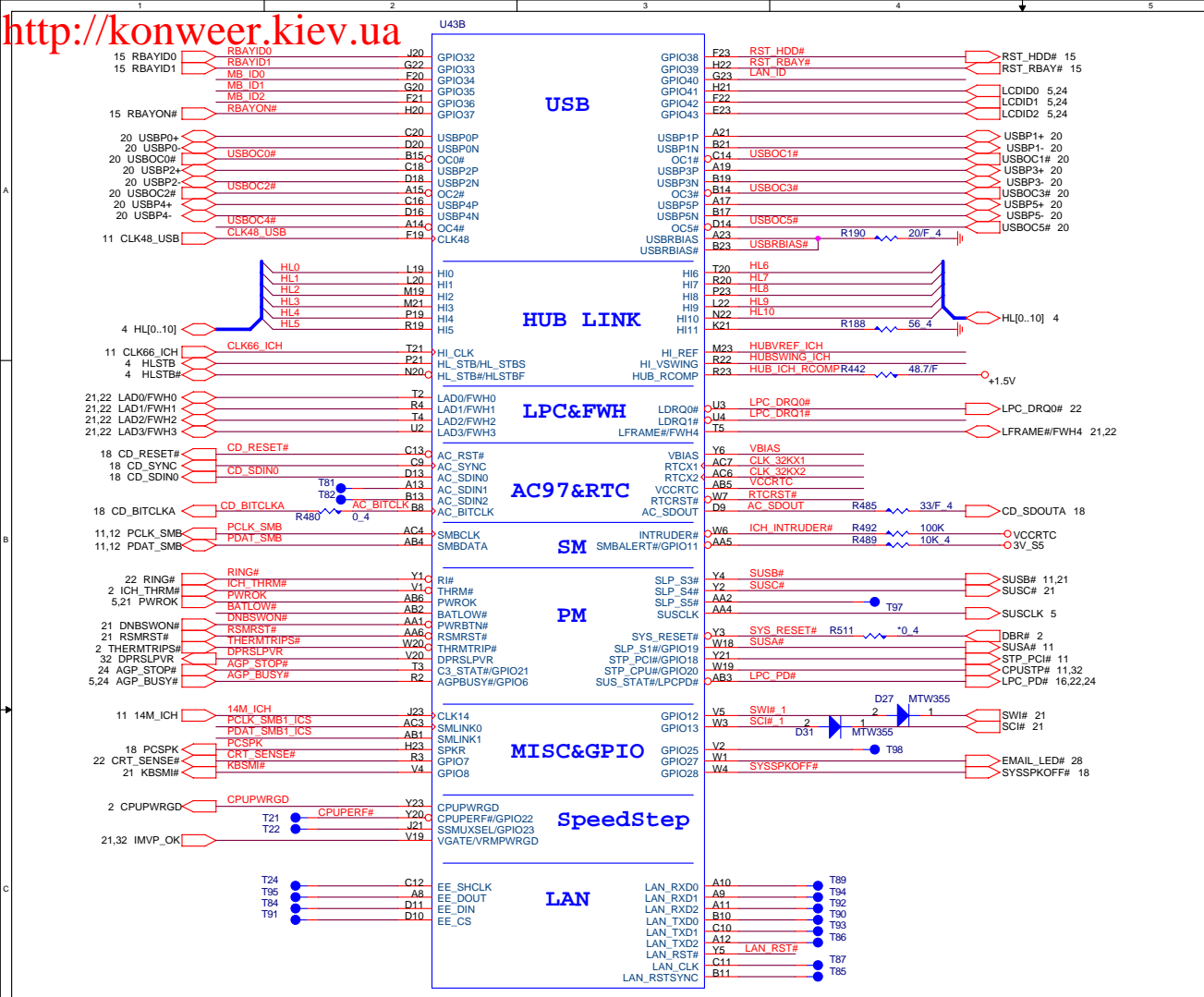

SMDDR_VTERM

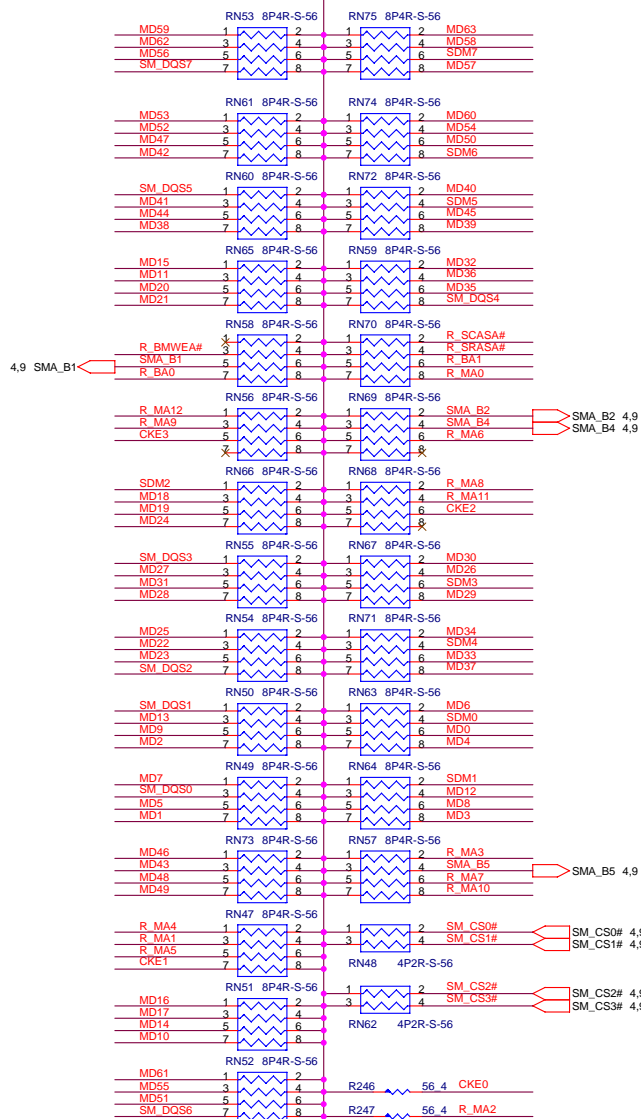

Damping put BOT, termination put TOP

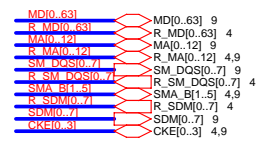

For terminal R-pack.

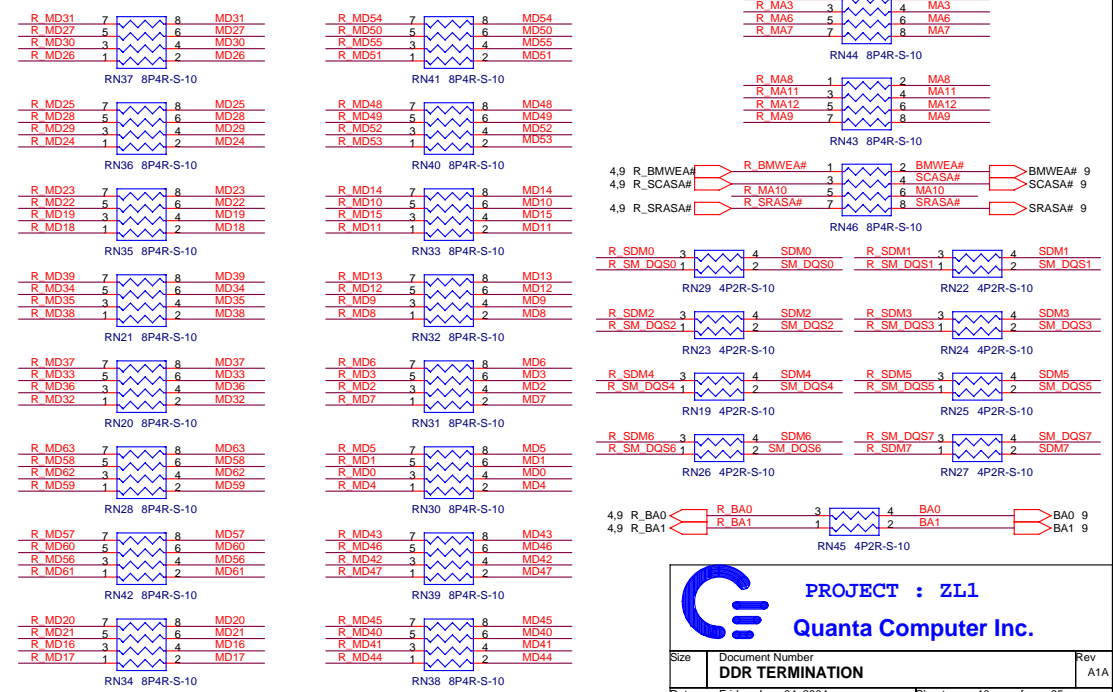
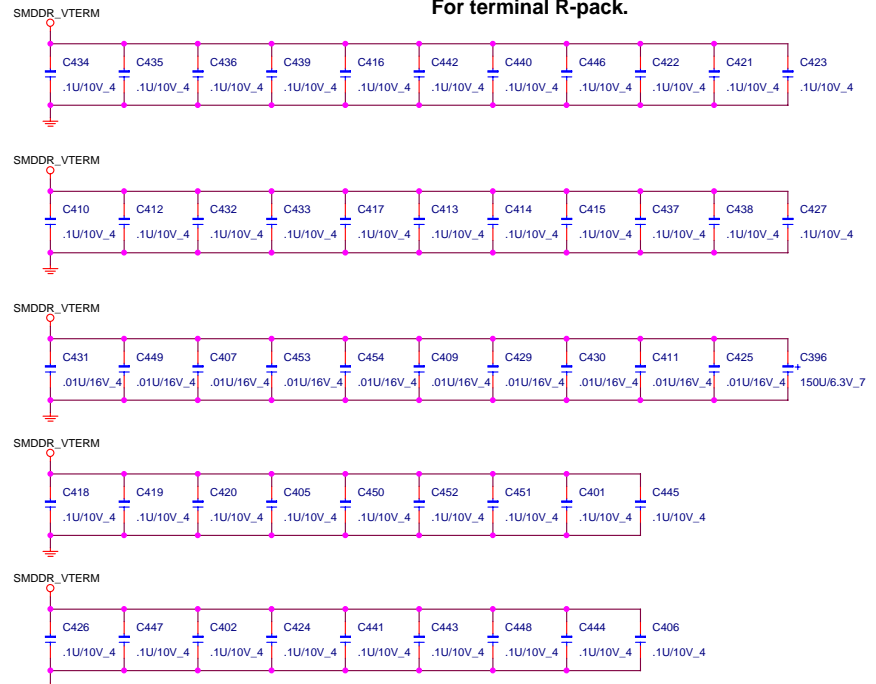

PROJECT : ZL1
Quanta Computer Inc.

Size: Document Number
DDR TERMINATION
 Date: Friday, June 04, 2004 Sheet 10 of 35 Rev A1A

<https://www.onsemi.com/pdf/datasheet/3V661.pdf>

1	0	0	66	66IN	66 Input
1	0	1	100	66IN	66 Input
1	1	0	200	66IN	66 Input
1	1	1	133	66IN	66 Input
0	0	0	66	66	66
0	0	1	100	66	66
0	1	0	200	66	66
0	1	1	133	66	66

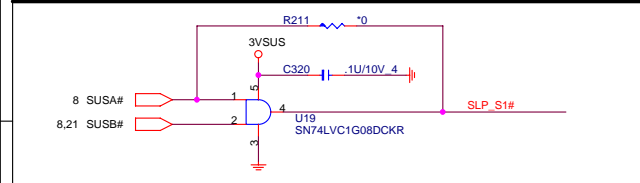
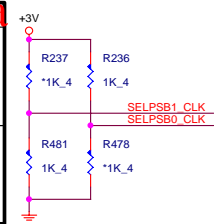

3V66_1/VCH
 SMBus Byte 0, Bit 5 = 0 66 MHz W S/S
 SMBus Byte 0, Bit 5 = 1 48 MHz W/O S/S

Byte 0, Bit 7 = 0 Disable Spread Spectrum
 Byte 0, Bit 7 = 1 Enable Spread Spectrum

Byte 4 Bit 7	Byte 5 Bit 7	Byte 5 Bit 6	Spread Mode	Spread %
SS2	SS1	SS0		
0	0	0	DOWN	+0.00, -0.25
0	0	1	DOWN	+0.00, -0.50
0	1	0	DOWN	+0.00, -0.75
0	1	1	DOWN	+0.00, -1.00
1	0	0	CENTER	+0.13, -0.13
1	0	1	CENTER	+0.25, -0.25
1	1	0	CENTER	+0.37, -0.37
1	1	1	CENTER	+0.50, -1.50

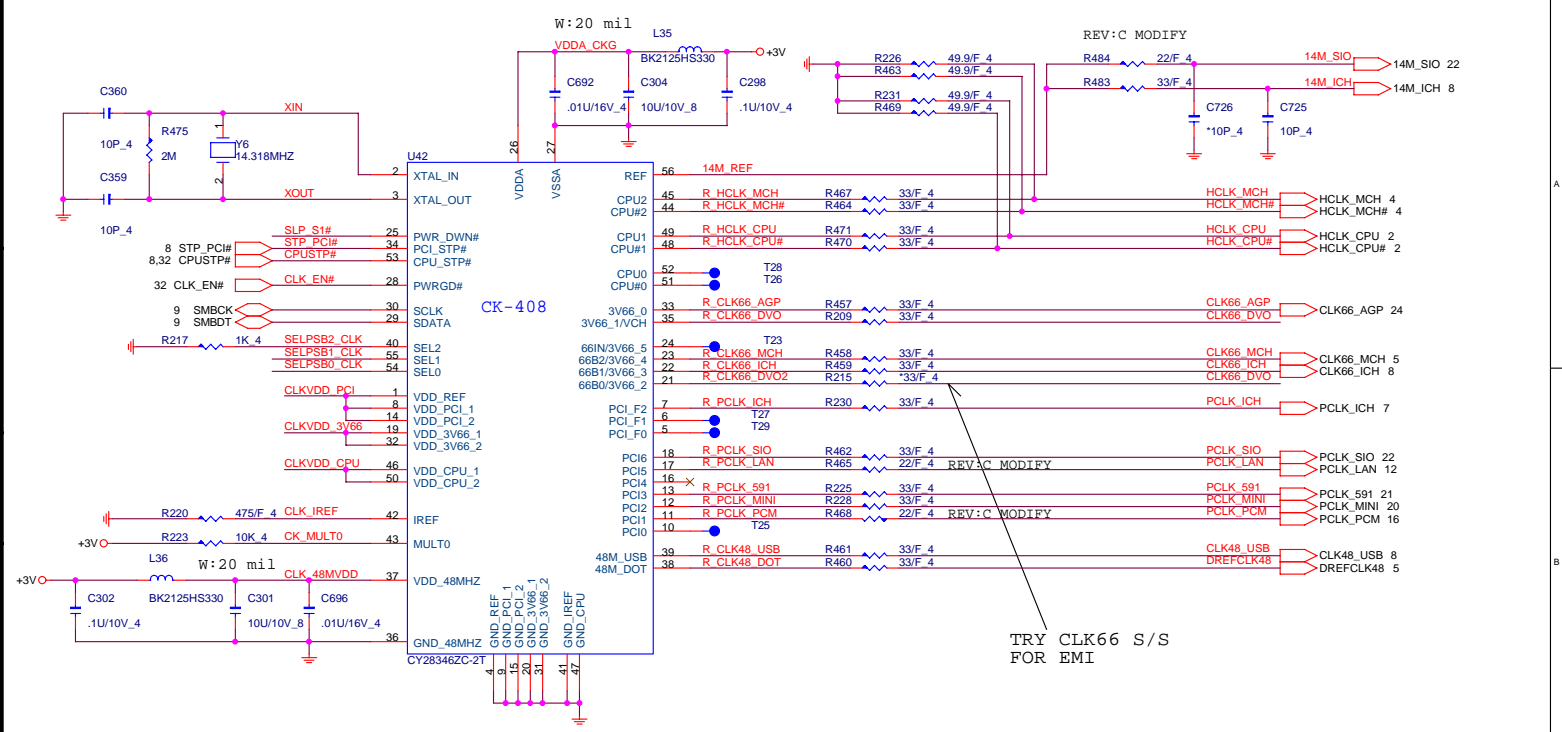

TRY CLK66 S/S FOR EMI

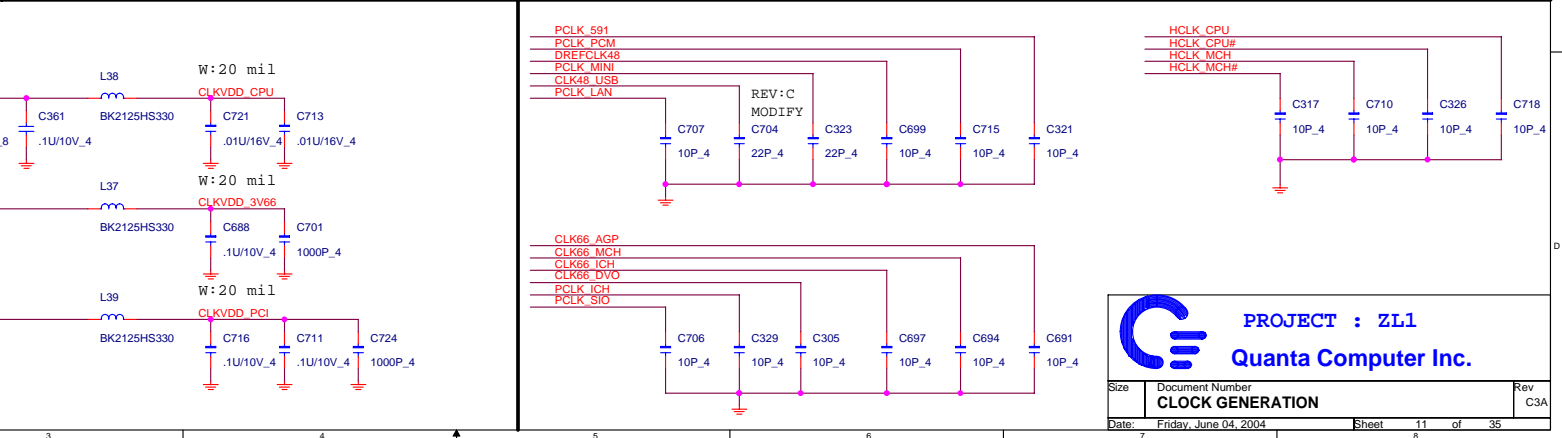
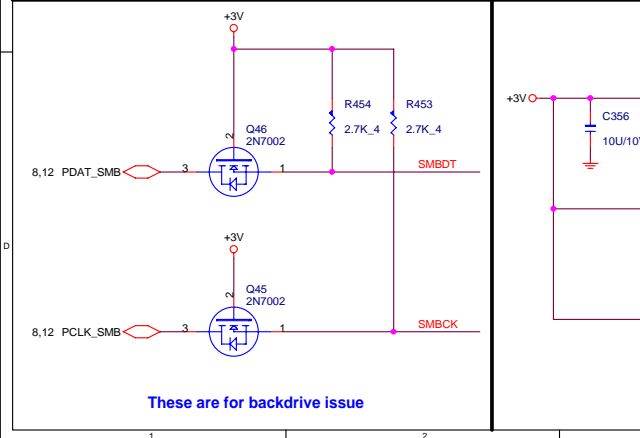
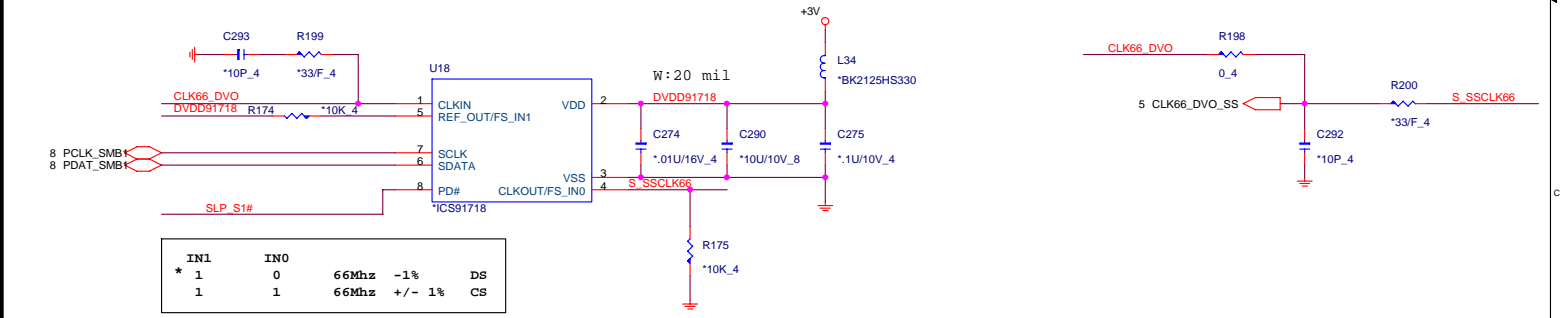

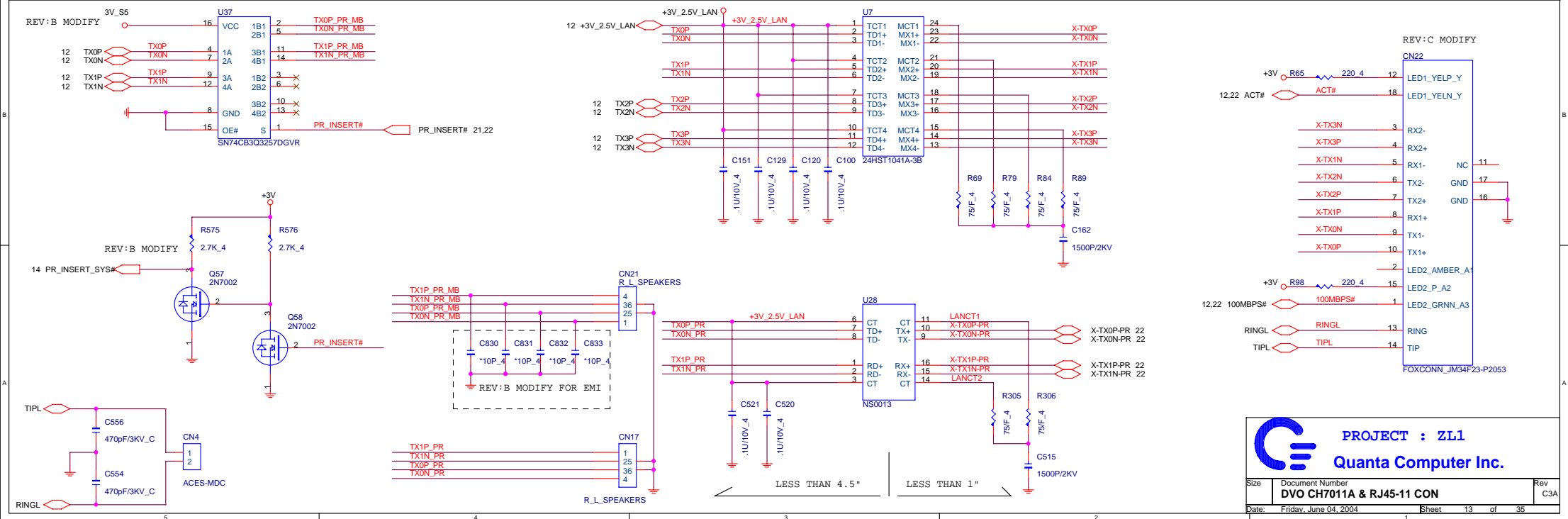
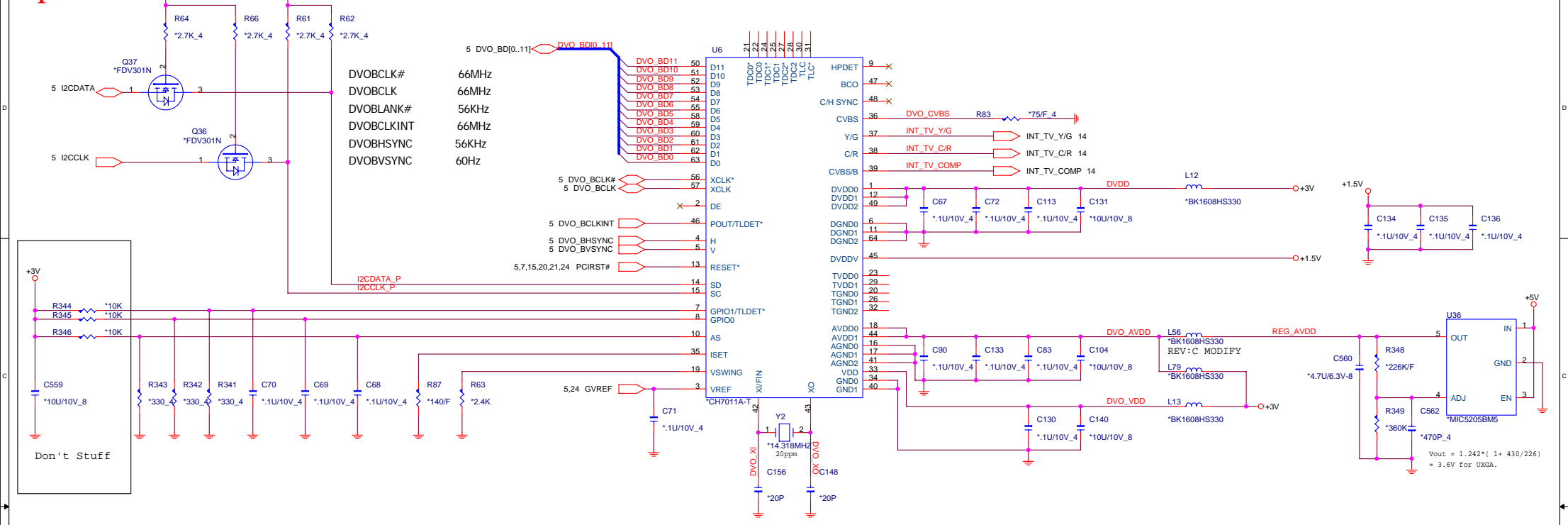

PROJECT : ZL1
Quanta Computer Inc.

Size	Document Number	Rev
	DVO CH7011A & RJ45-11 CON	CSA
Date:	Friday, June 04, 2004	Sheet 13 of 35

SEL	FUNCTION
LOW	IN_B0
HIGH	IN_B1

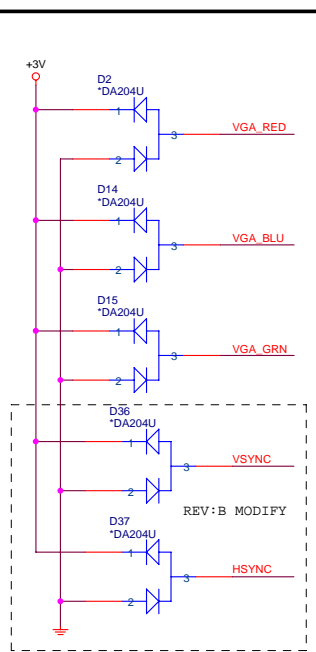
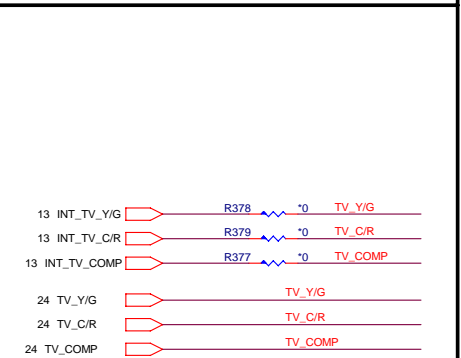
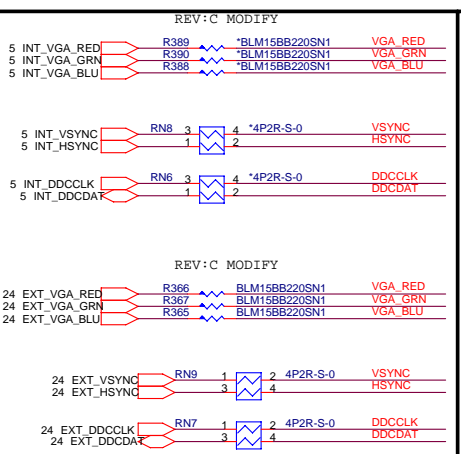
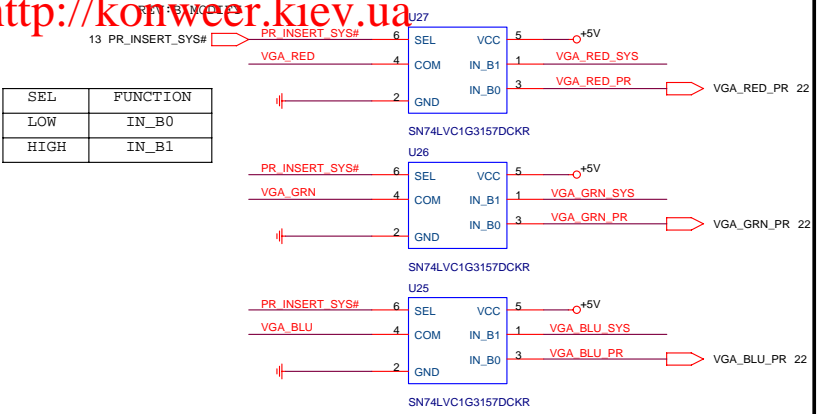

CRT PORT

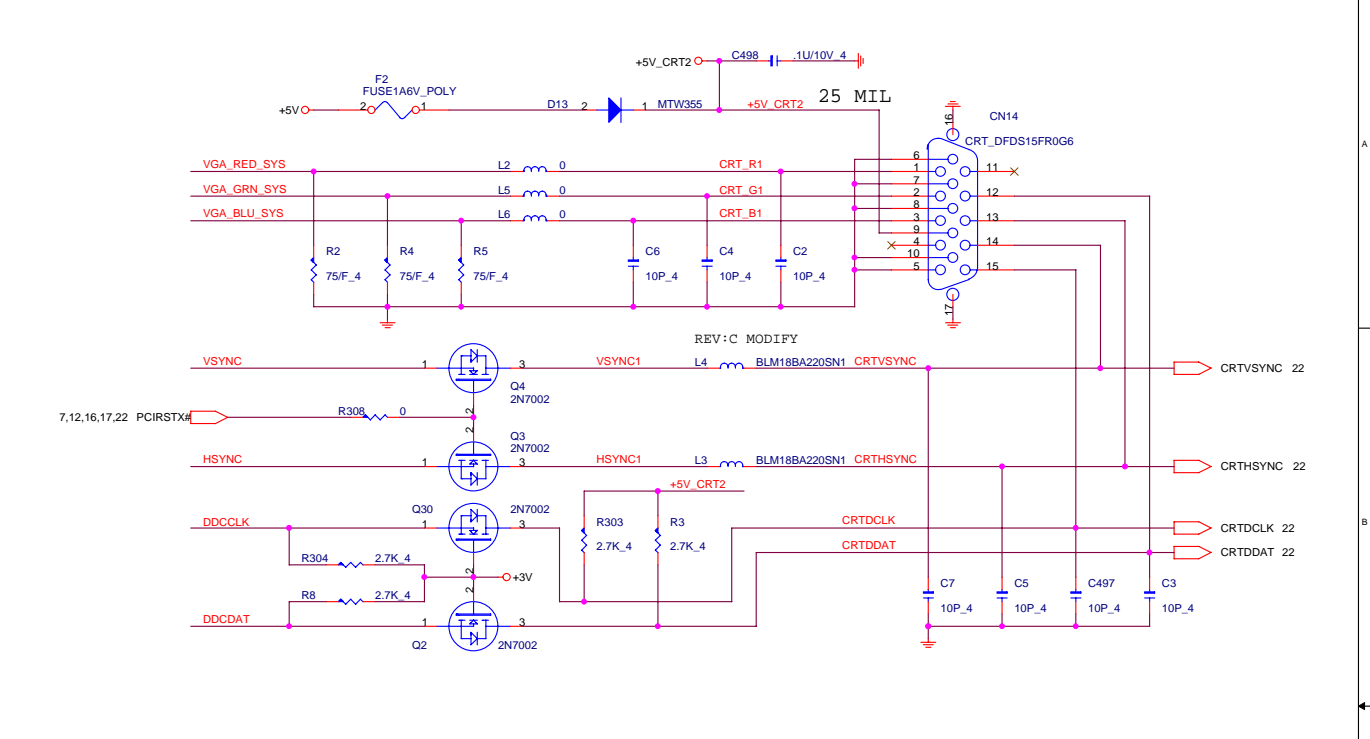

S-VIDEO

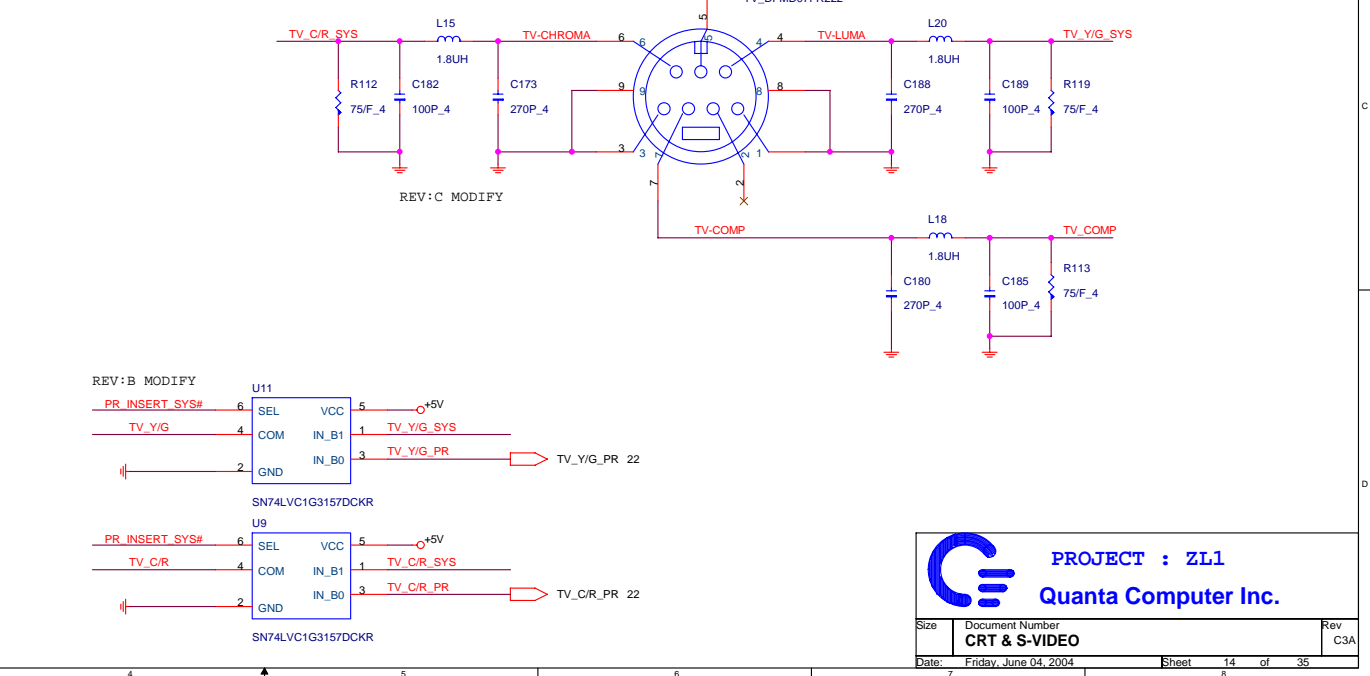

PROJECT : ZL1
Quanta Computer Inc.

Size	Document Number	Rev
	CRT & S-VIDEO	C3A
Date:	Friday, June 04, 2004	Sheet 14 of 35

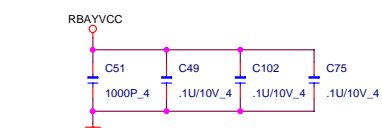
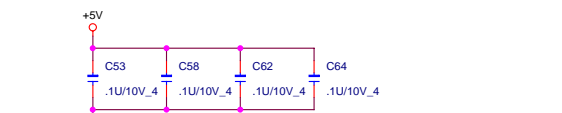
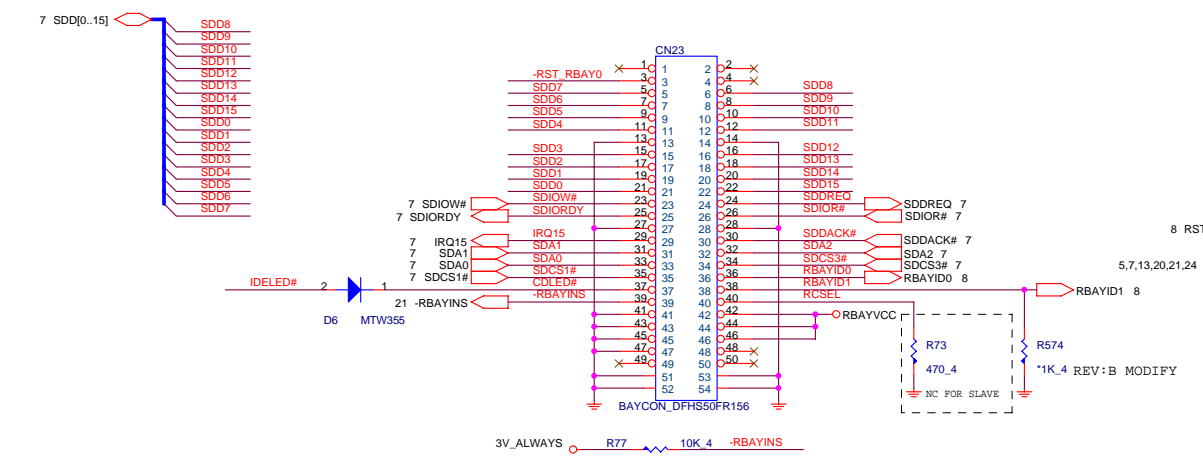
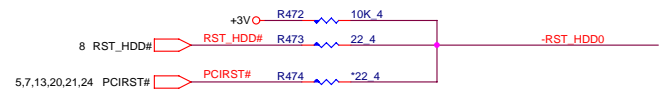
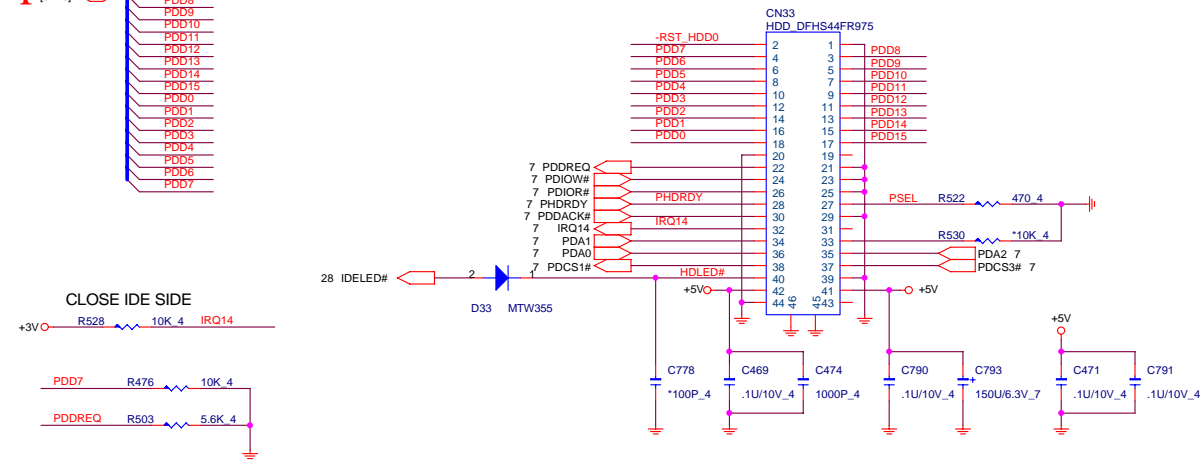

BAY ID STATUS

RBAYID0/ LBAYID0	RBAYID1/ LBAYID1	STATUS
0	0	FDD
0	1	HDD
1	0	CD/DVD

Component	W/O Media Bay	W Media Bay
R472, R473	DNS	STUFF
R94, R96	DNS	STUFF
R474, R101	STUFF	DNS
R48, R50	STUFF	DNS
Q10, Q35	DNS	STUFF
R340, C553	DNS	STUFF
R73, CN23	DNS	STUFF
R51, CN19	STUFF	DNS
R574	STUFF	DNS

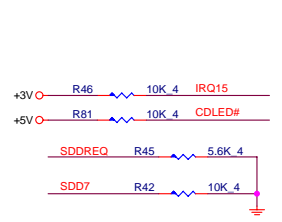

ODD Connector

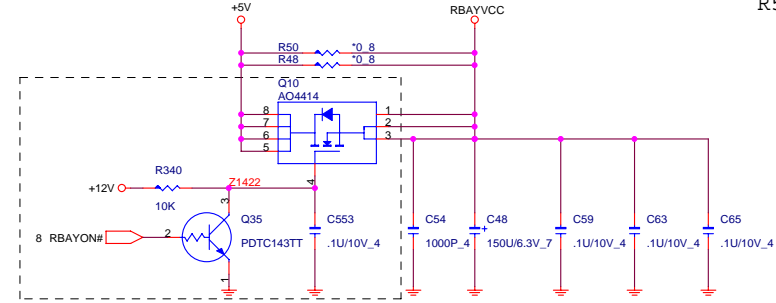
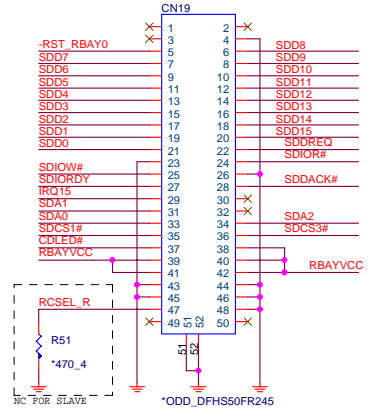

PROJECT : ZL1
Quanta Computer Inc.

Size	Document Number	Rev
	HDD & CDROM & MEDIA BAY	B2B
Date:	Friday, June 04, 2004	Sheet 15 of 35

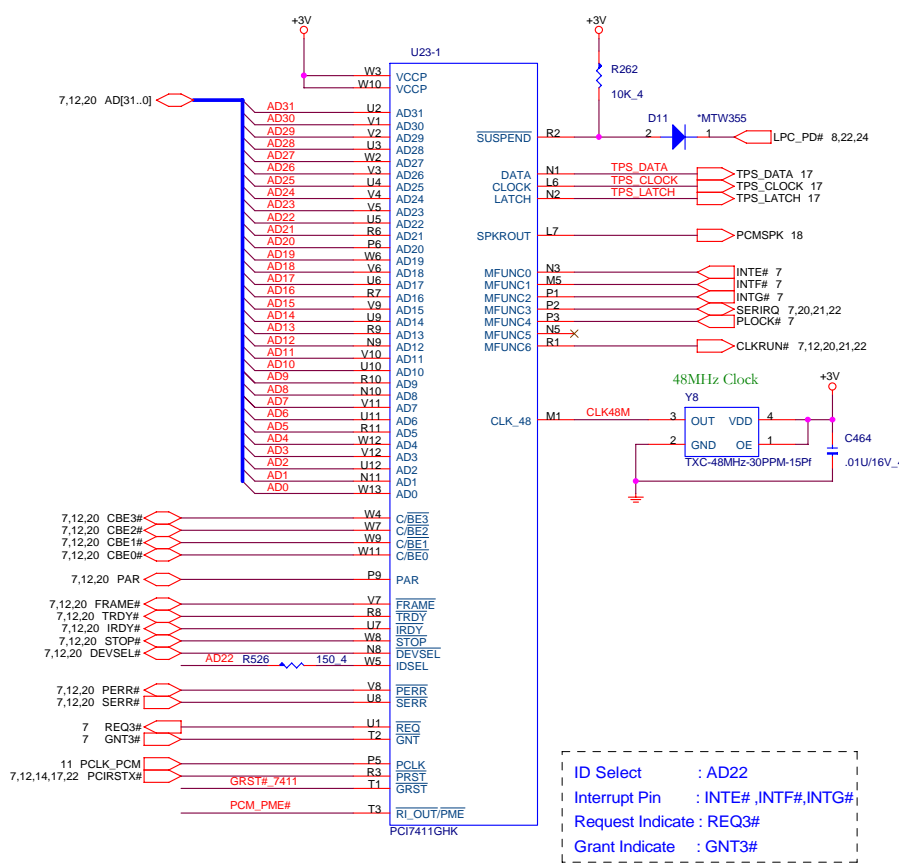

ID Select : AD22
 Interrupt Pin : INTE#, INTF#, INTG#
 Request Indicate : REQ3#
 Grant Indicate : GNT3#

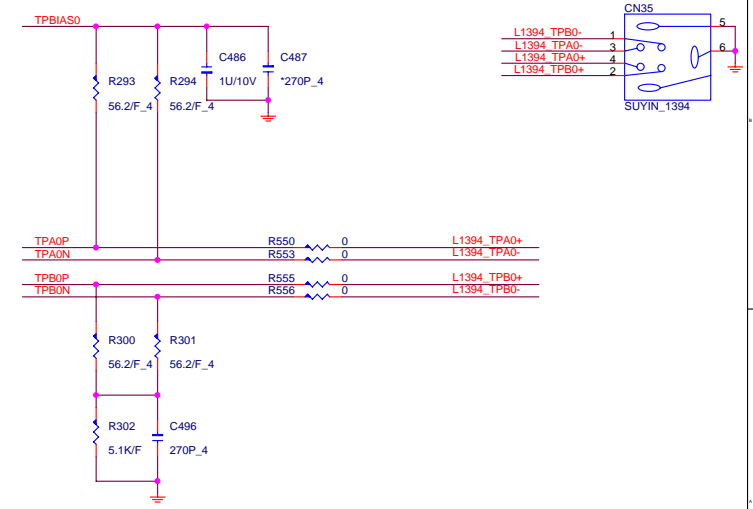
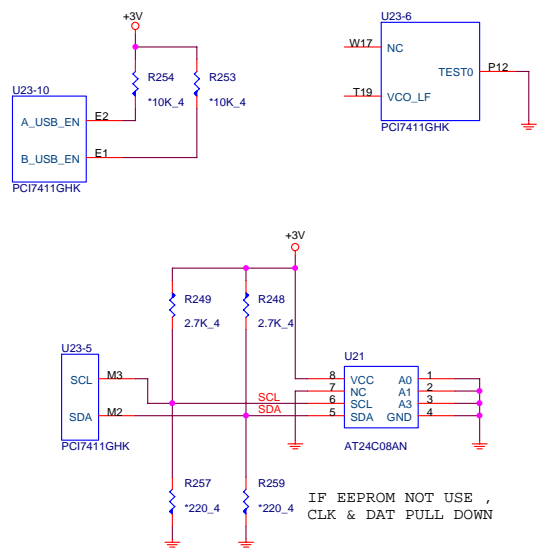
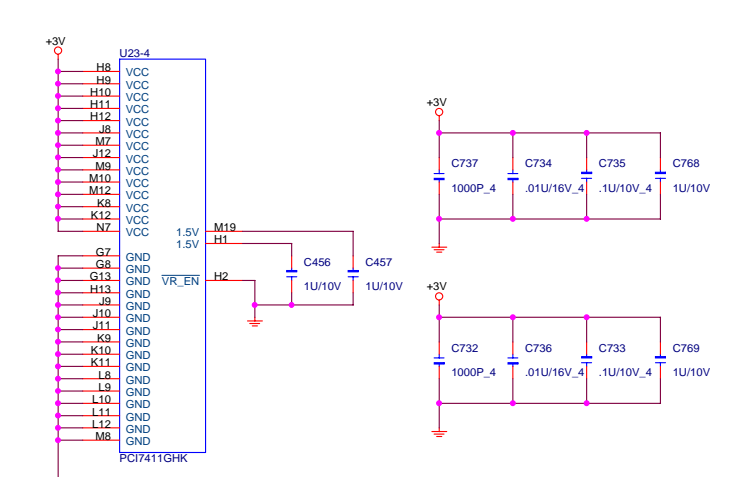
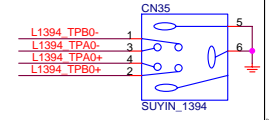
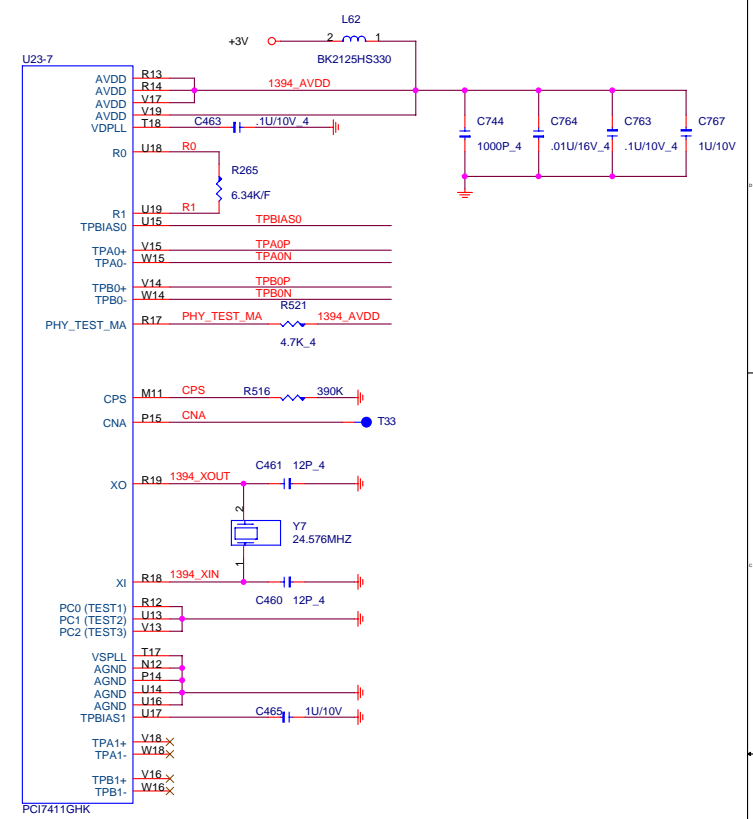
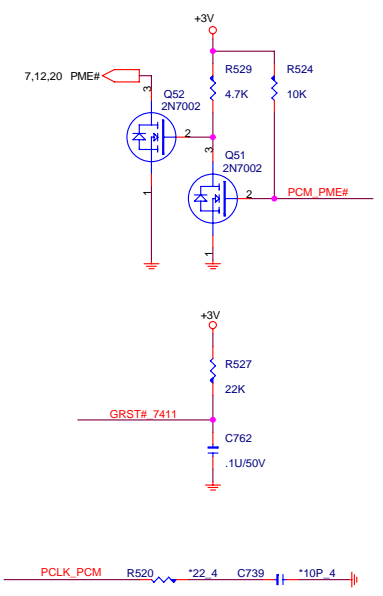

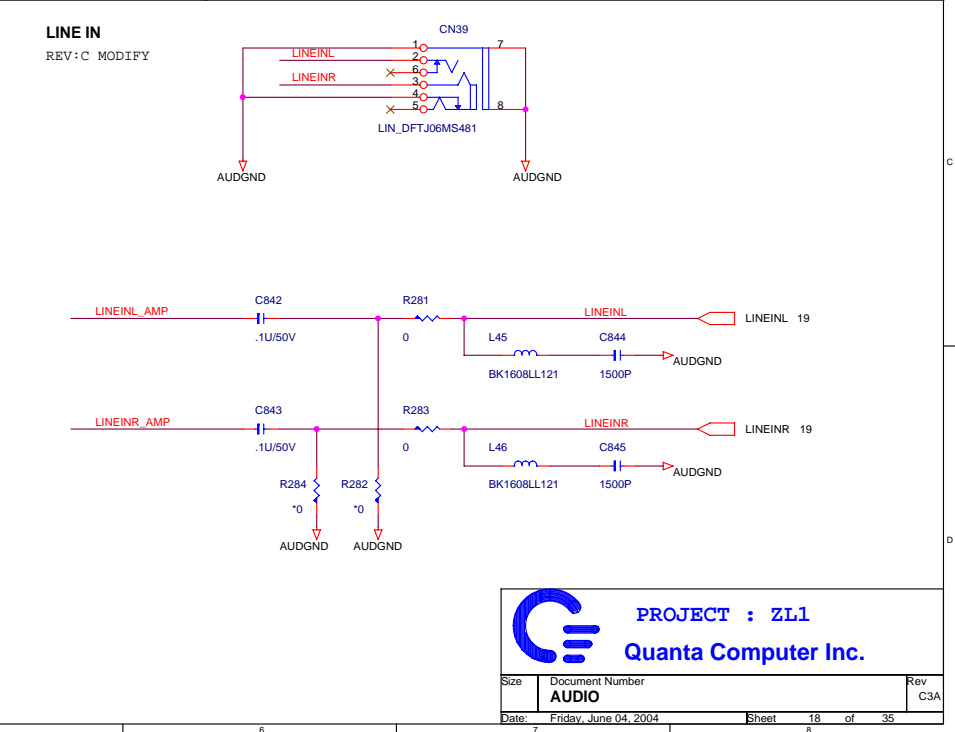
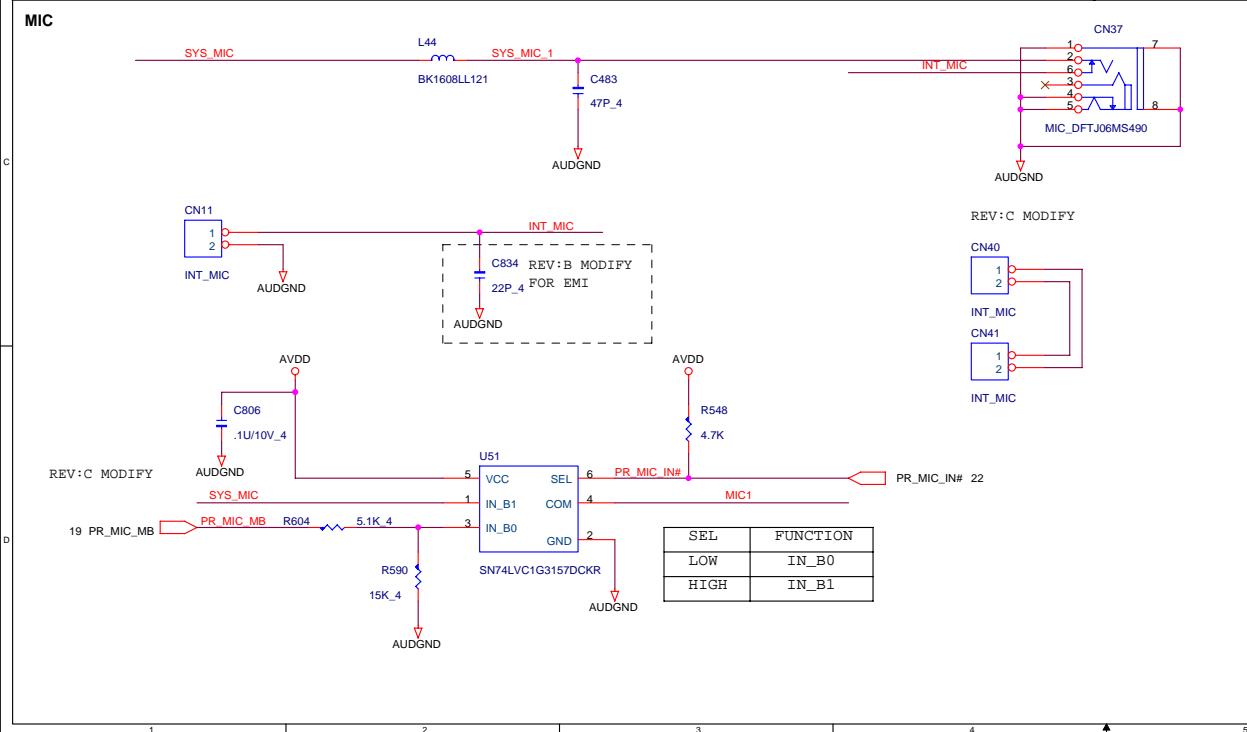
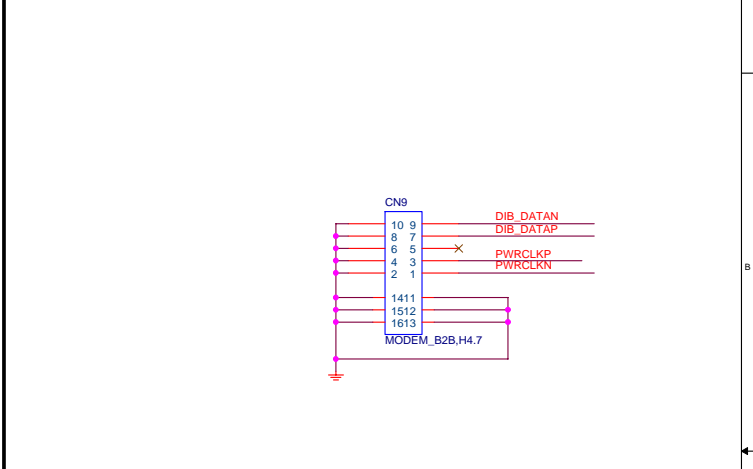
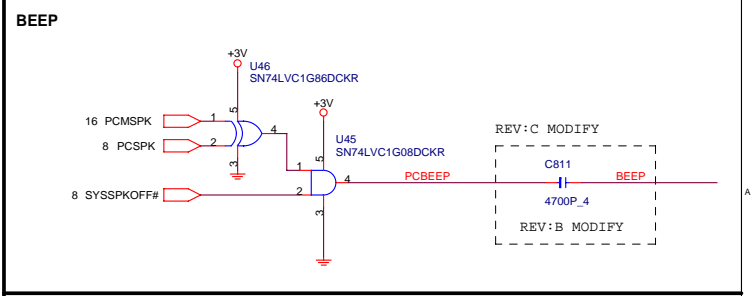
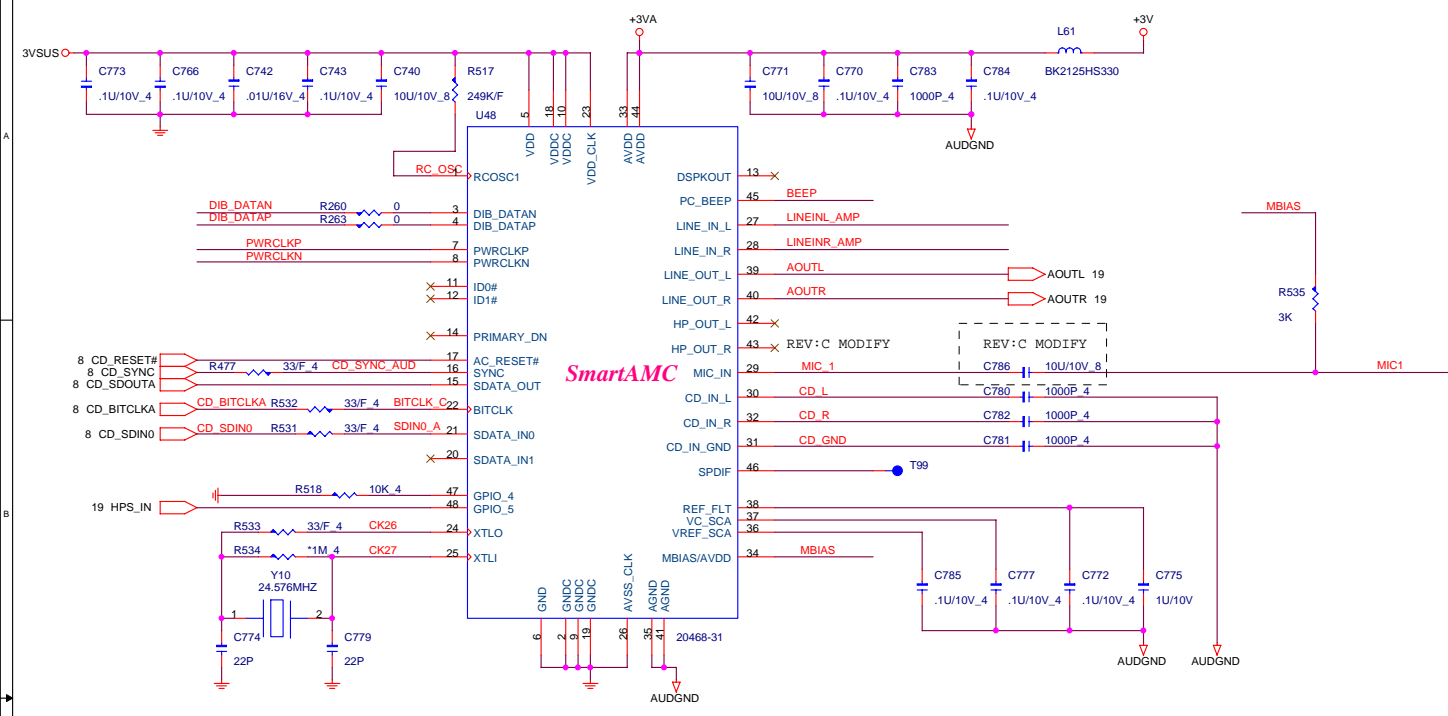

GAIN1	SPKR MODE	HP MODE
0	10.5	3
1	9	0

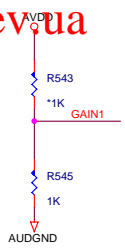

AMP POWER

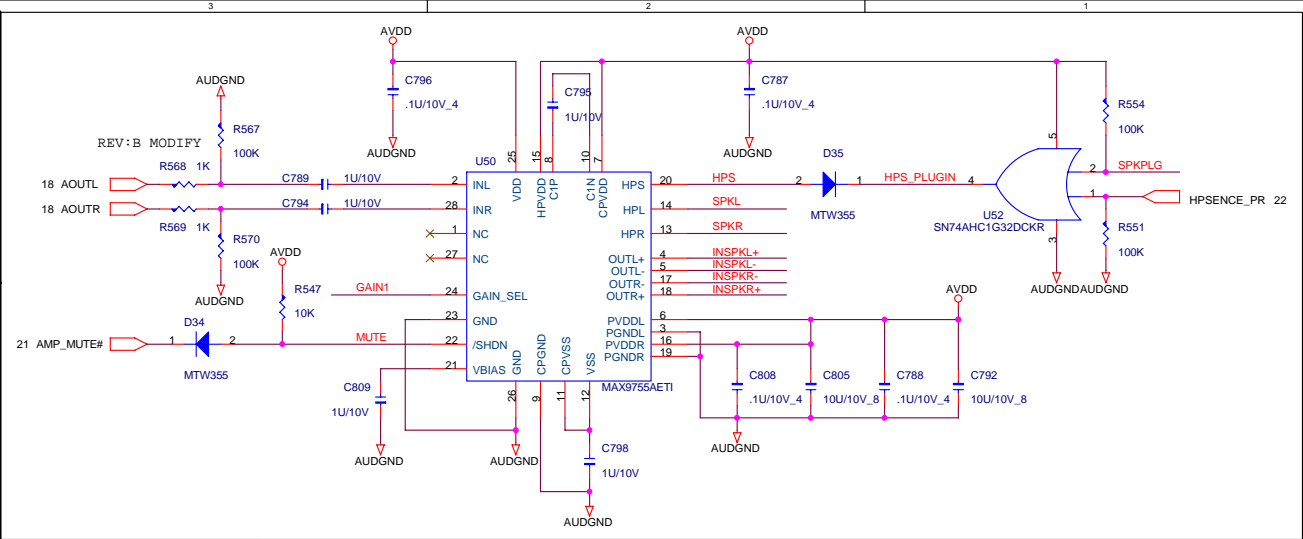
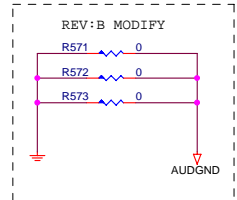
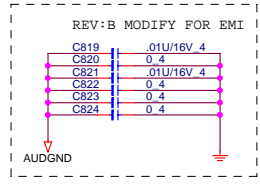
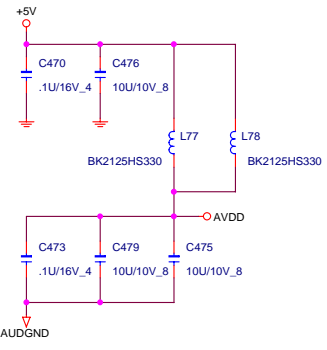

SPEAKER CON.

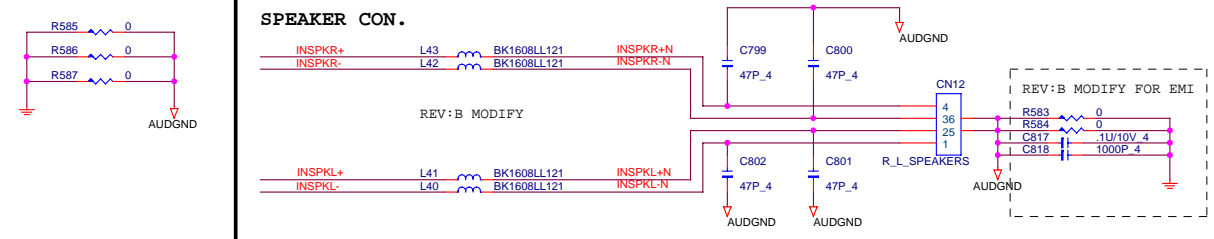

LINE OUT

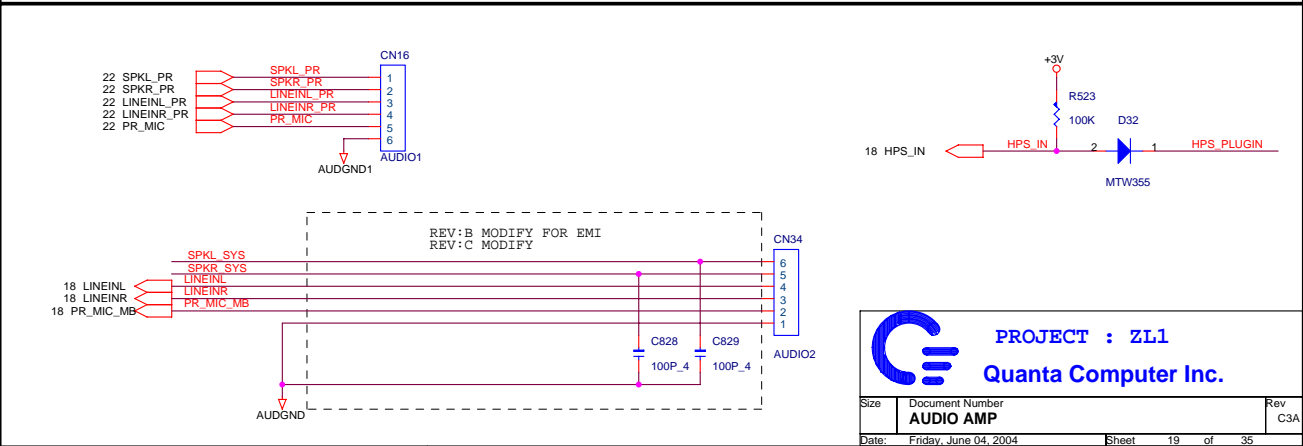
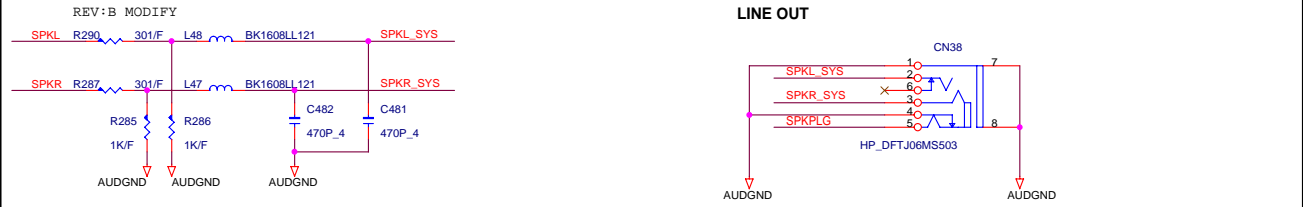

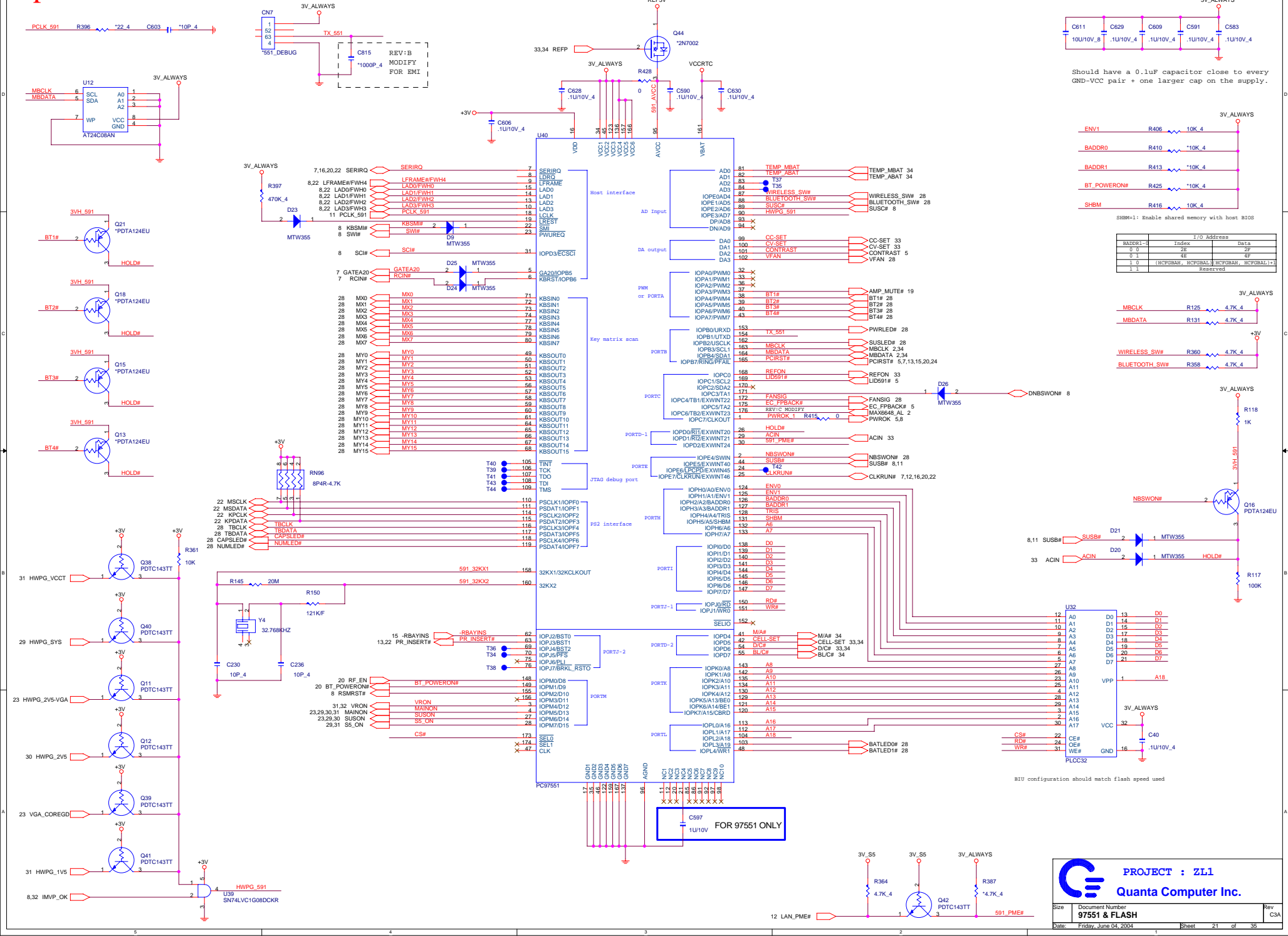

Should have a 0.1uF capacitor close to every GND-VCC pair + one larger cap on the supply.

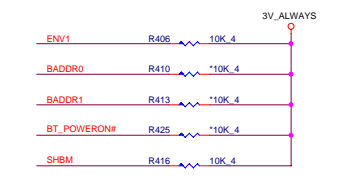

I/O Address	Index	Data
BADDR0	0	2E
BADDR1	1	4E
BADDR2	2	4E
BADDR3	3	4E
BADDR4	4	4E
BADDR5	5	4E
BADDR6	6	4E
BADDR7	7	4E
BADDR8	8	4E
BADDR9	9	4E
BADDR10	10	4E
BADDR11	11	4E
BADDR12	12	4E
BADDR13	13	4E
BADDR14	14	4E
BADDR15	15	4E
BADDR16	16	4E
BADDR17	17	4E
BADDR18	18	4E
BADDR19	19	4E
BADDR20	20	4E
BADDR21	21	4E
BADDR22	22	4E
BADDR23	23	4E
BADDR24	24	4E
BADDR25	25	4E
BADDR26	26	4E
BADDR27	27	4E
BADDR28	28	4E
BADDR29	29	4E
BADDR30	30	4E
BADDR31	31	4E
BADDR32	32	4E
BADDR33	33	4E
BADDR34	34	4E
BADDR35	35	4E
BADDR36	36	4E
BADDR37	37	4E
BADDR38	38	4E
BADDR39	39	4E
BADDR40	40	4E
BADDR41	41	4E
BADDR42	42	4E
BADDR43	43	4E
BADDR44	44	4E
BADDR45	45	4E
BADDR46	46	4E
BADDR47	47	4E
BADDR48	48	4E
BADDR49	49	4E
BADDR50	50	4E
BADDR51	51	4E
BADDR52	52	4E
BADDR53	53	4E
BADDR54	54	4E
BADDR55	55	4E
BADDR56	56	4E
BADDR57	57	4E
BADDR58	58	4E
BADDR59	59	4E
BADDR60	60	4E
BADDR61	61	4E
BADDR62	62	4E
BADDR63	63	4E
BADDR64	64	4E
BADDR65	65	4E
BADDR66	66	4E
BADDR67	67	4E
BADDR68	68	4E
BADDR69	69	4E
BADDR70	70	4E
BADDR71	71	4E
BADDR72	72	4E
BADDR73	73	4E
BADDR74	74	4E
BADDR75	75	4E
BADDR76	76	4E
BADDR77	77	4E
BADDR78	78	4E
BADDR79	79	4E
BADDR80	80	4E
BADDR81	81	4E
BADDR82	82	4E
BADDR83	83	4E
BADDR84	84	4E
BADDR85	85	4E
BADDR86	86	4E
BADDR87	87	4E
BADDR88	88	4E
BADDR89	89	4E
BADDR90	90	4E
BADDR91	91	4E
BADDR92	92	4E
BADDR93	93	4E
BADDR94	94	4E
BADDR95	95	4E
BADDR96	96	4E
BADDR97	97	4E
BADDR98	98	4E
BADDR99	99	4E
BADDR100	100	4E

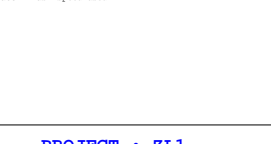
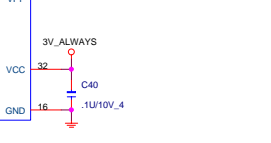
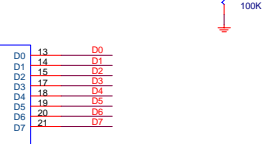
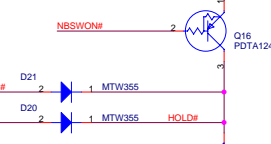
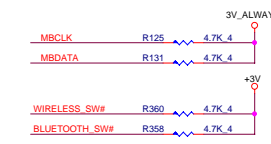

BU configuration should match flash speed used

PROJECT : ZL1
Quanta Computer Inc.

Size	Document Number	Rev
	97551 & FLASH	C3A
Date	Friday, June 04, 2004	Sheet 21 of 35

MINI-PCI

Interrupt Pin : INTB#, INTCA#
Request Indicate : REQ1#
Grant Indicate : GNT1#

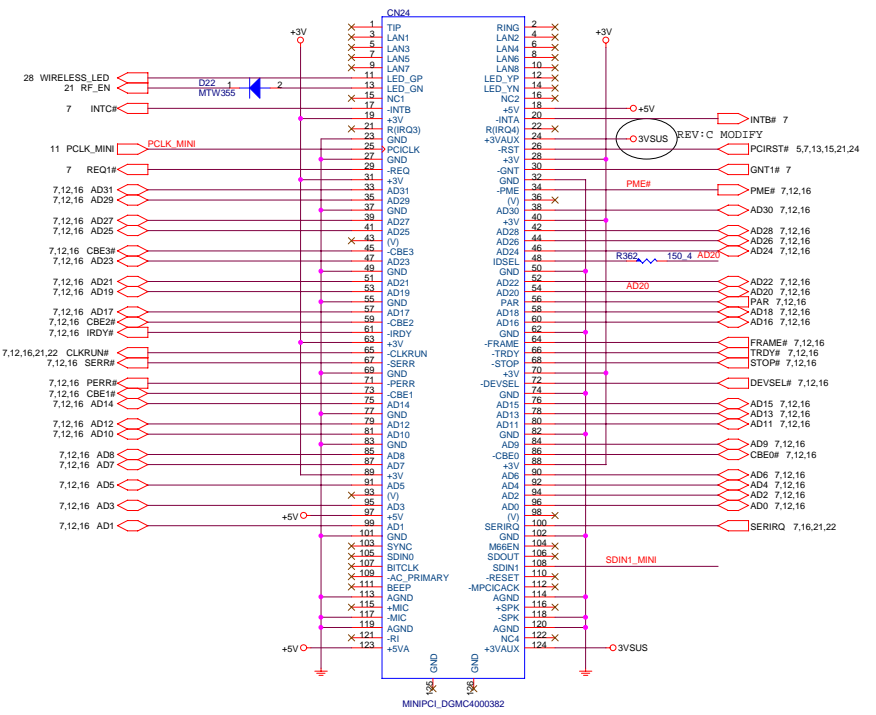

MINIPCI_DGMC4000382

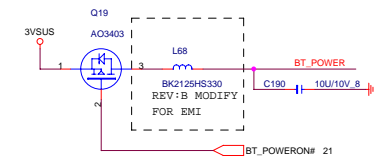
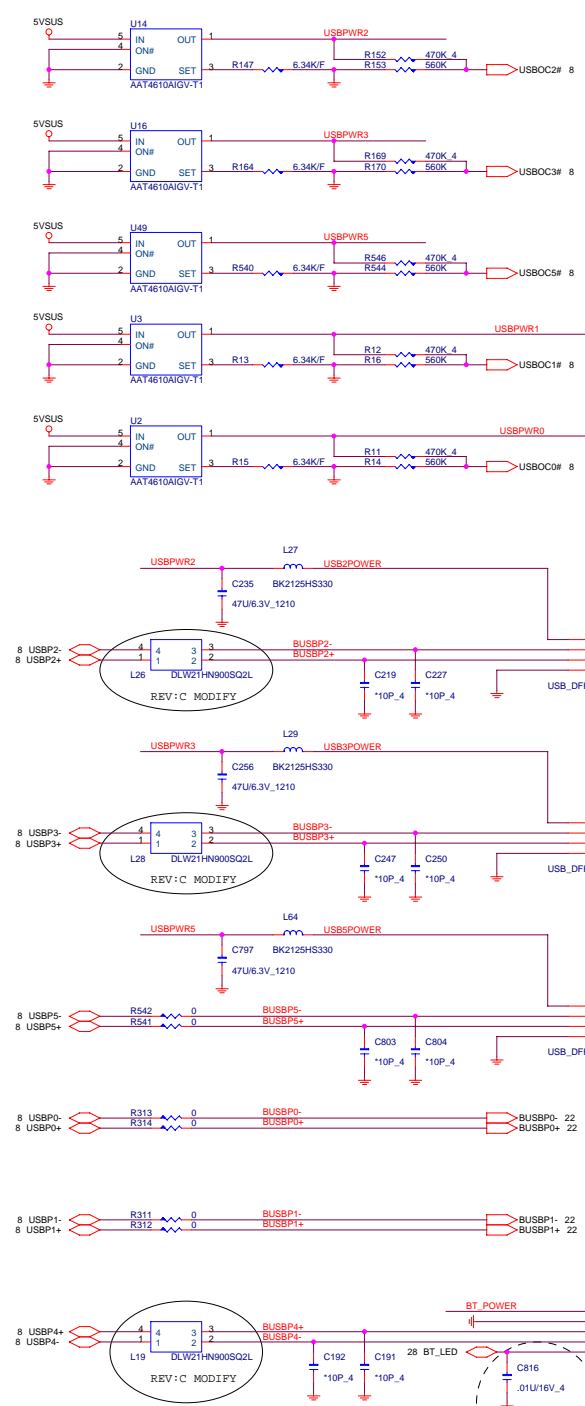
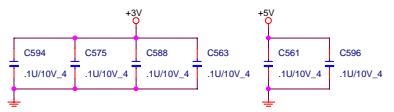

PROJECT : ZL1
Quanta Computer Inc.

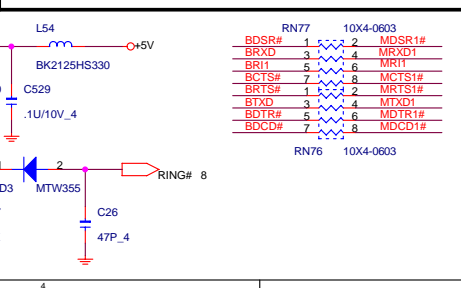
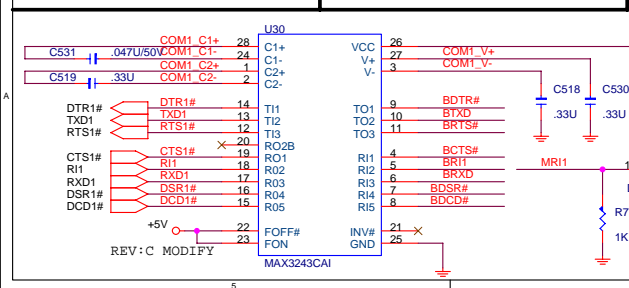
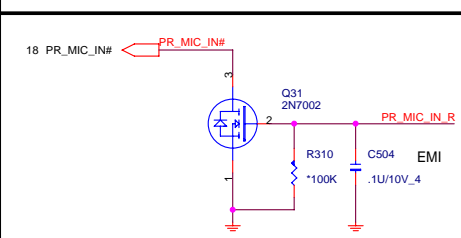
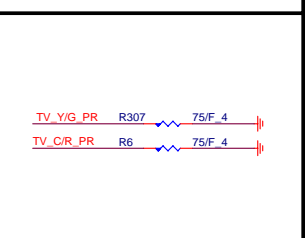
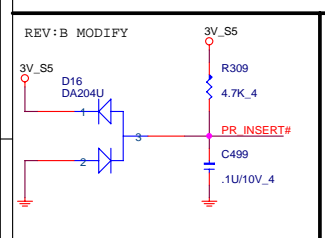
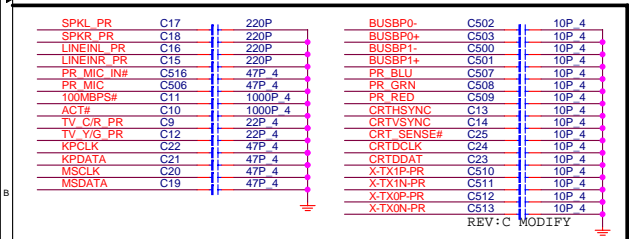
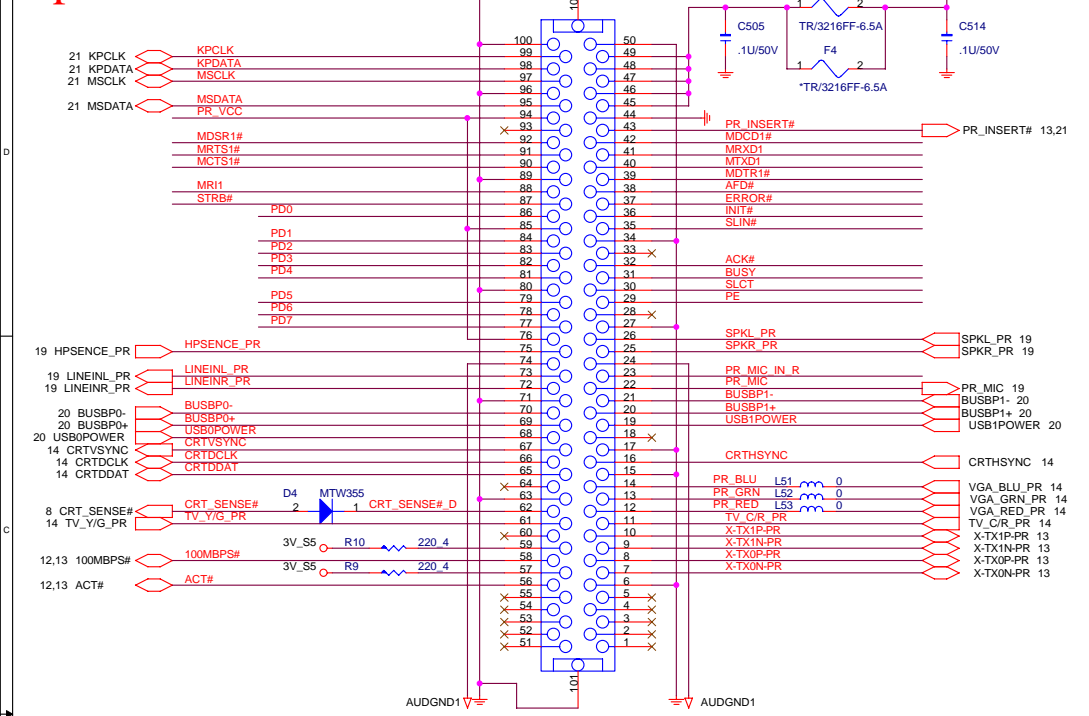

SUPER I/O

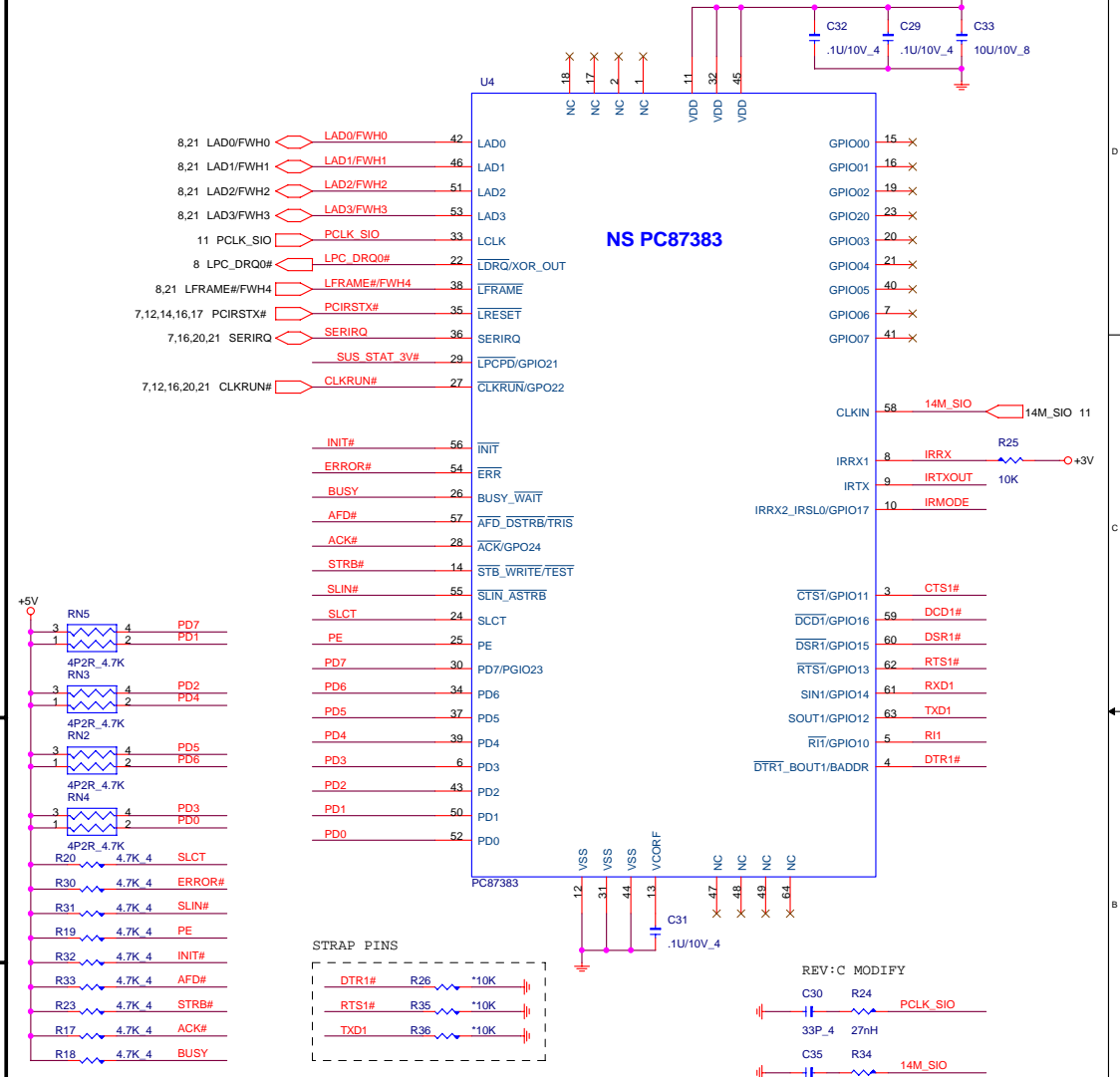

IrDA

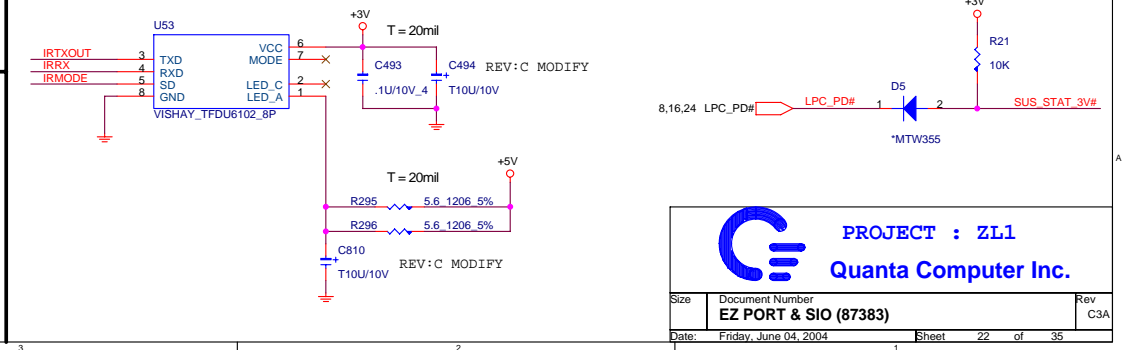



PROJECT : ZL1
Quanta Computer Inc.

Size	Document Number	Rev
	EZ PORT & SIO (87383)	C3A
Date:	Friday, June 04, 2004	Sheet 22 of 35

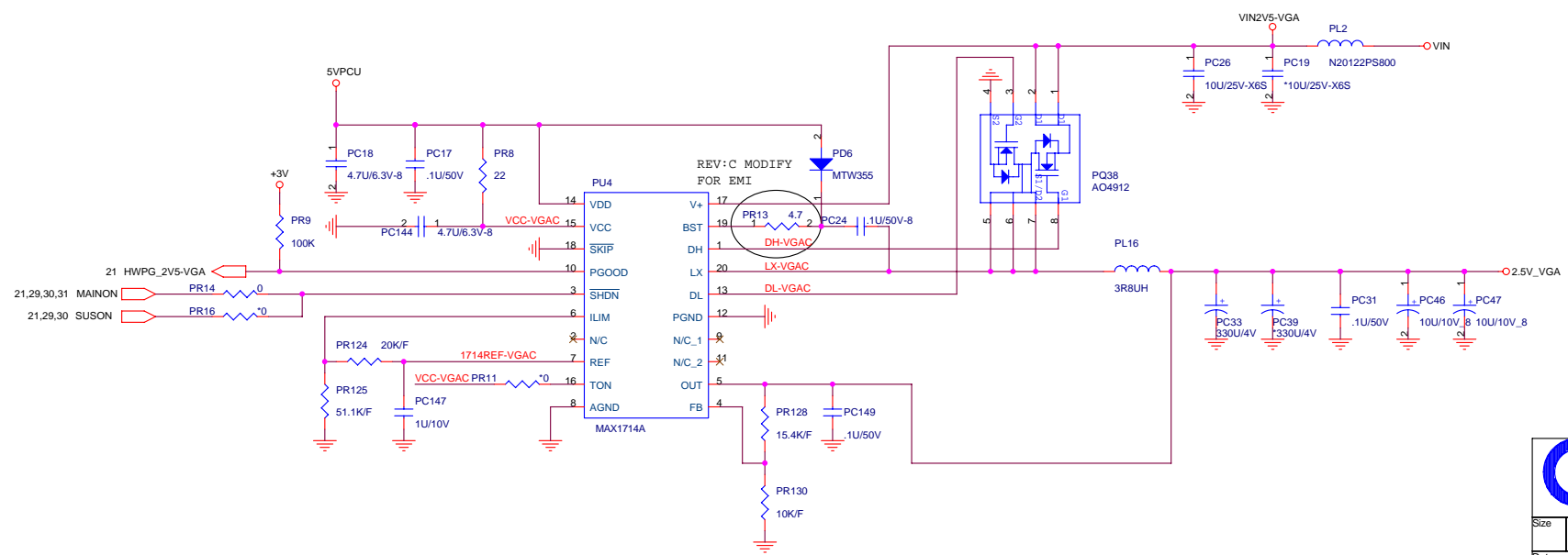
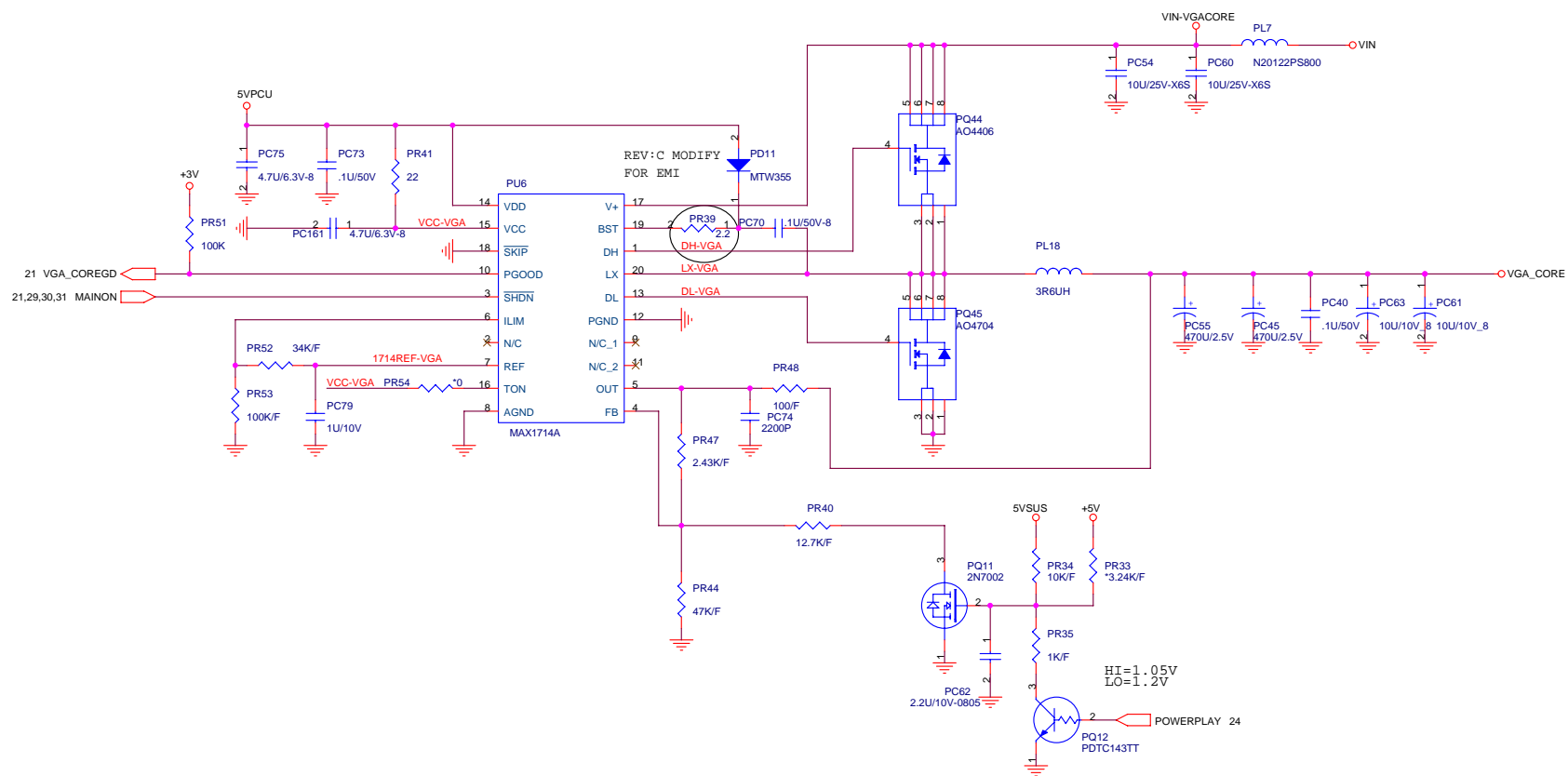

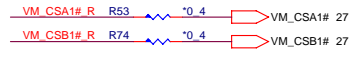
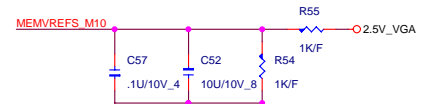
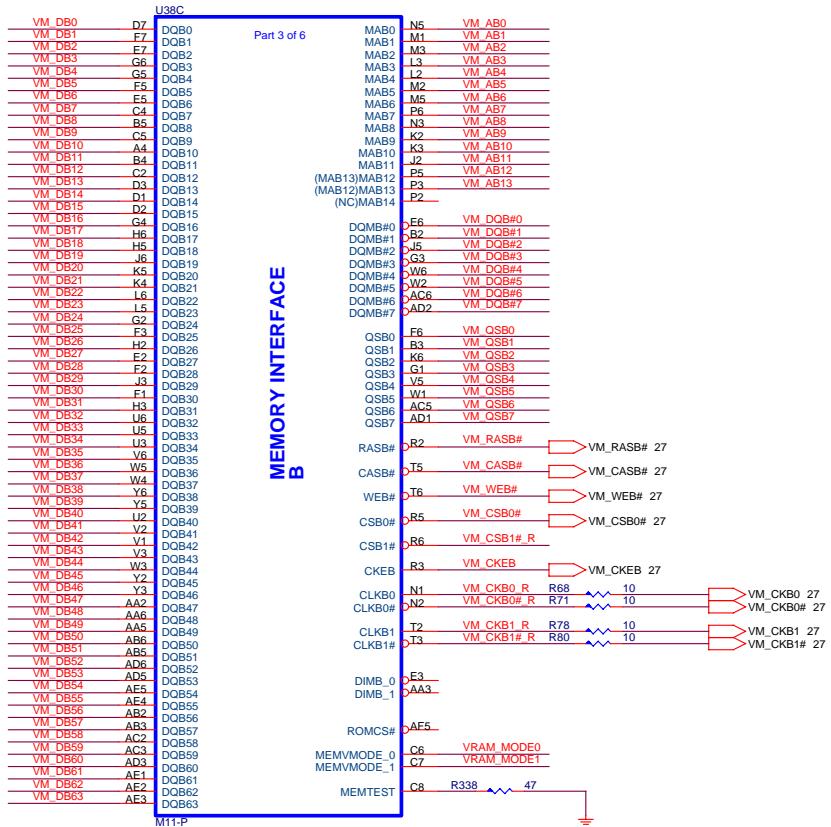
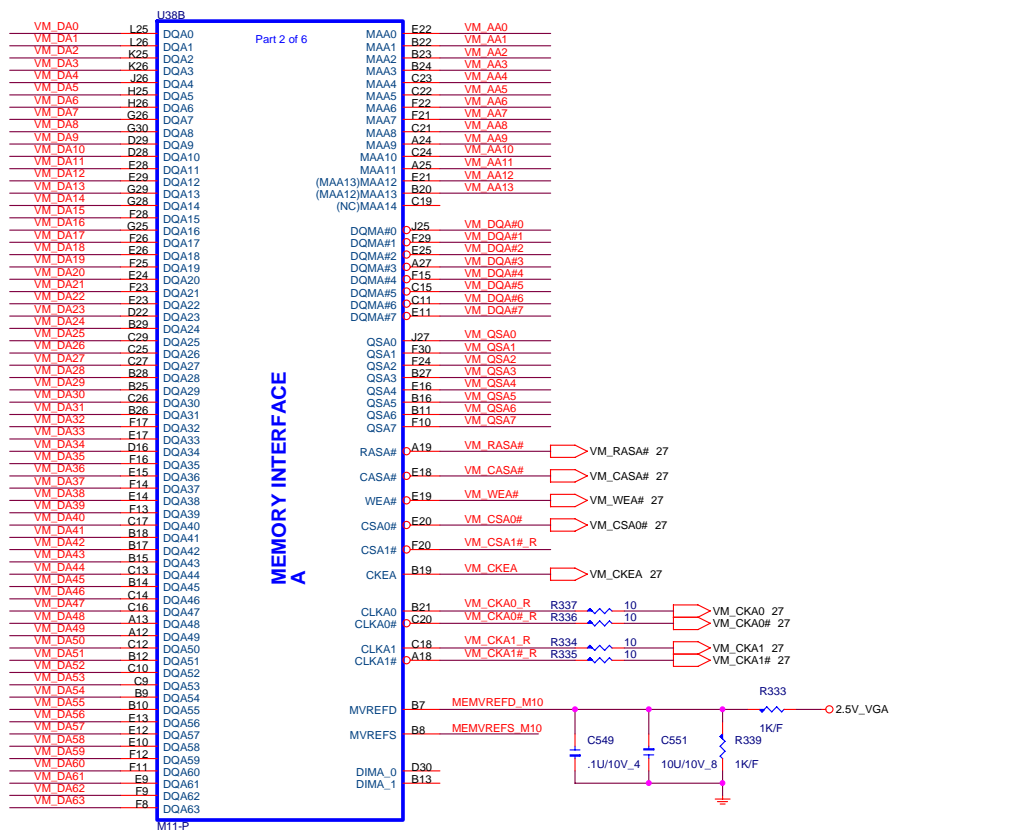
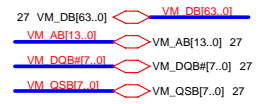
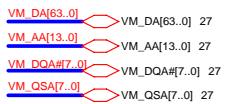

Mount these parts when use hynix 256Mb(8Mx32) VRAM chip

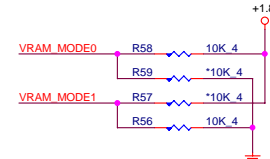

	VRAM_MODE1	VRAM_MODE0
2.5V	0	1
1.8V	1	0
2.8V	1	1

VRAM type setting

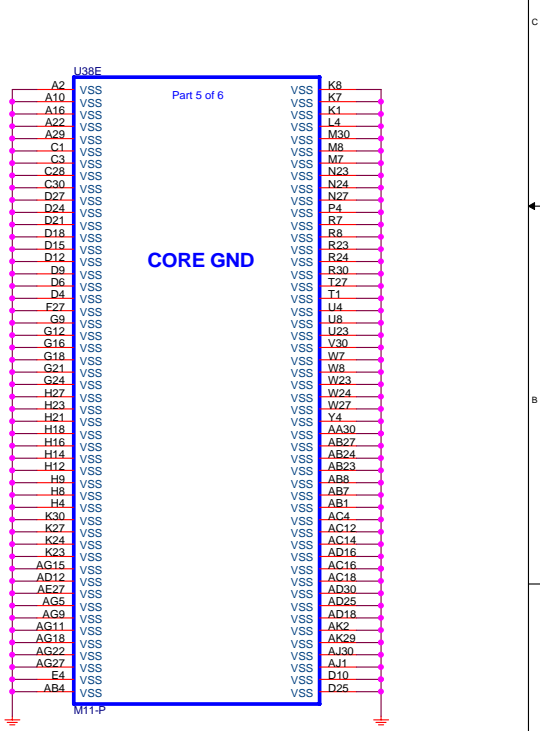
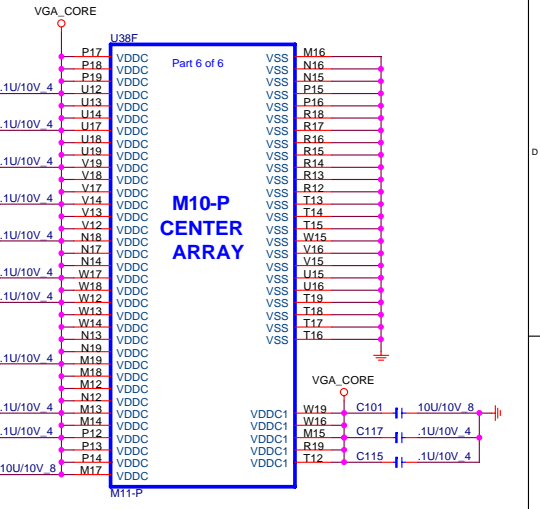
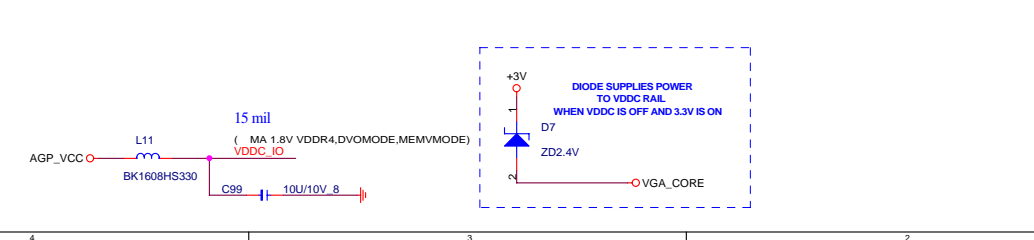
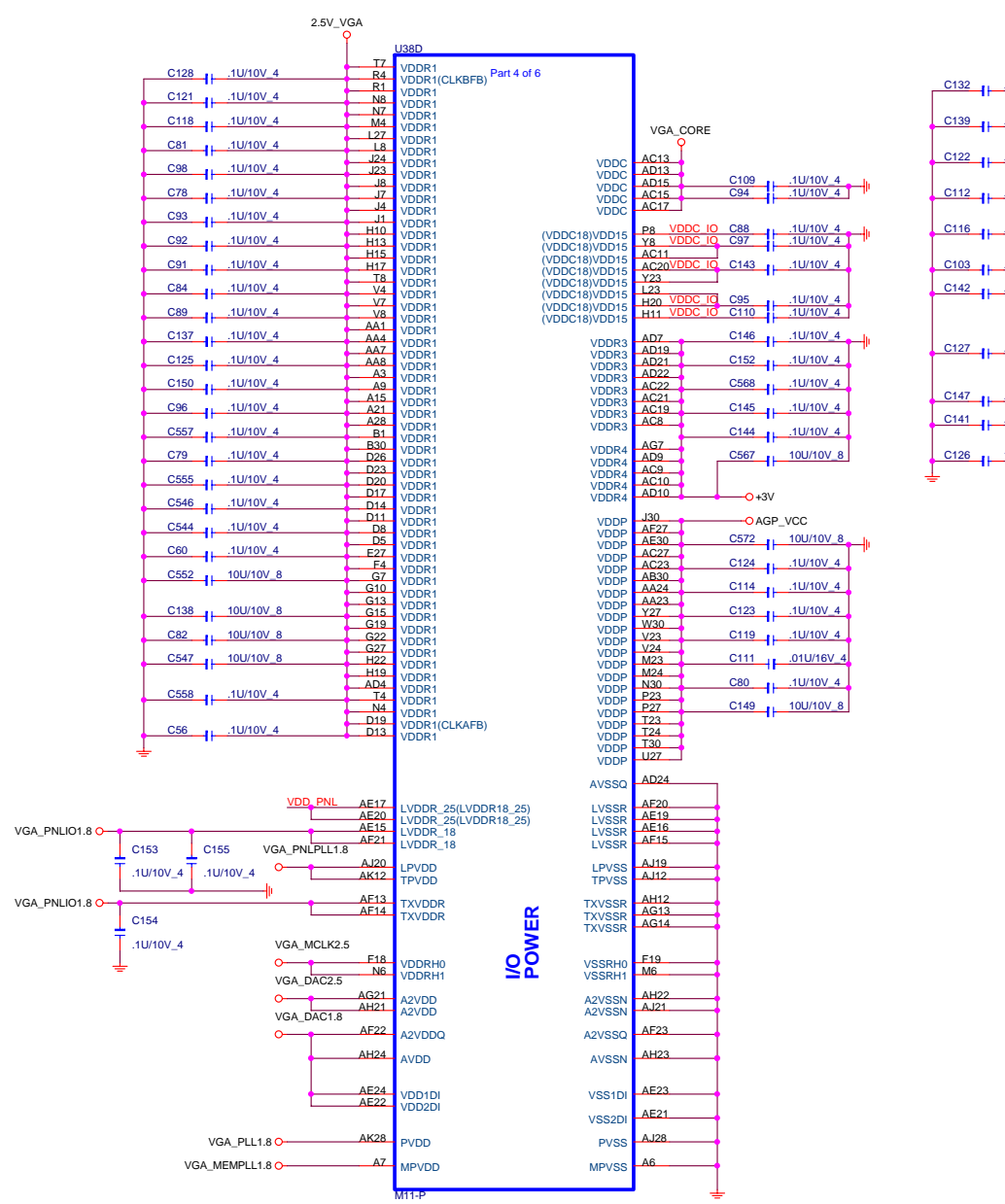
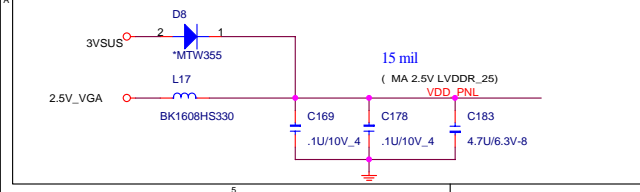
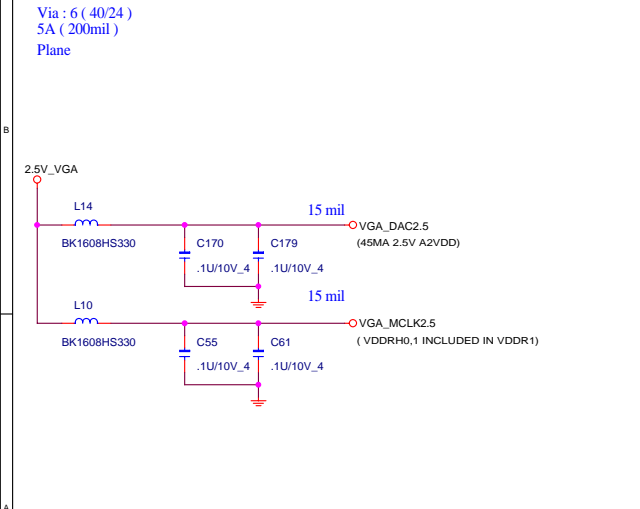
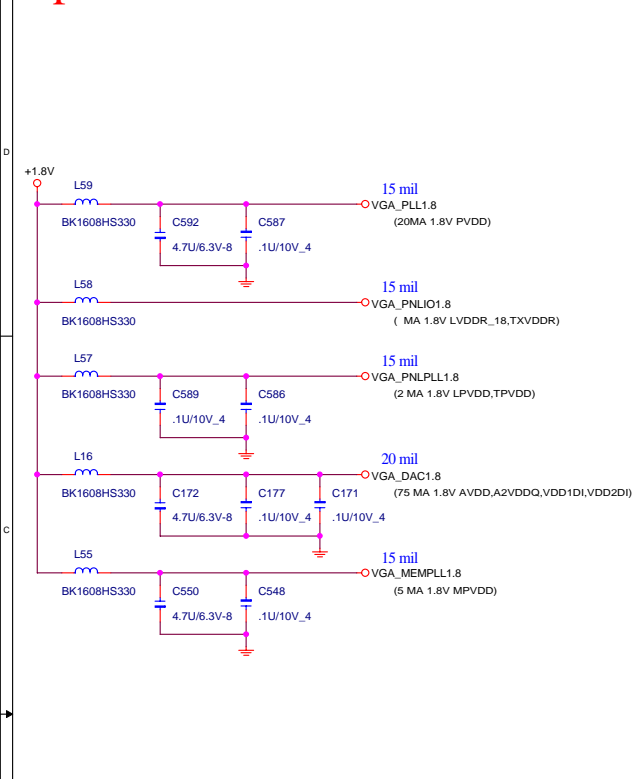

VRAM Channel A

VRAM Channel B

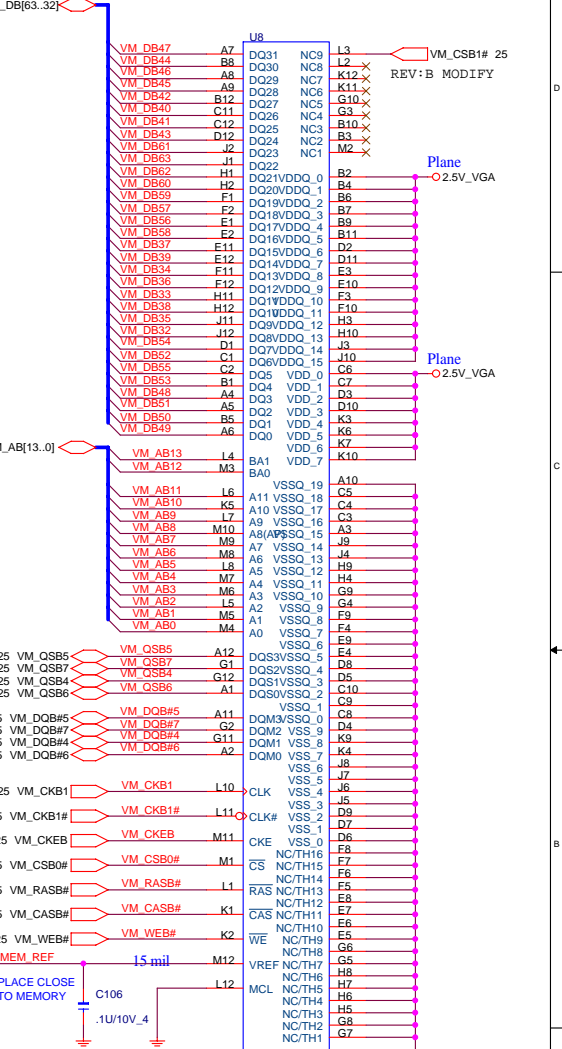
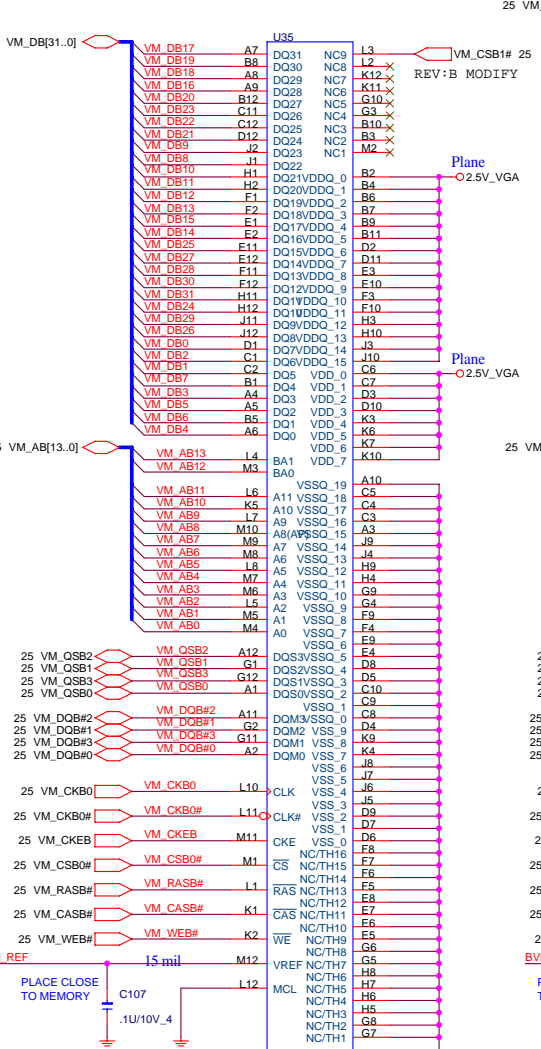
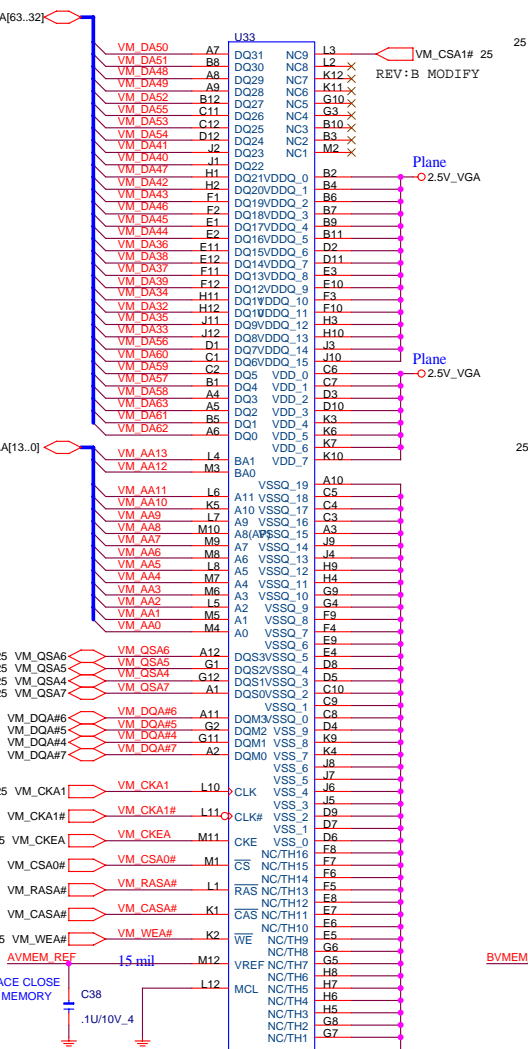
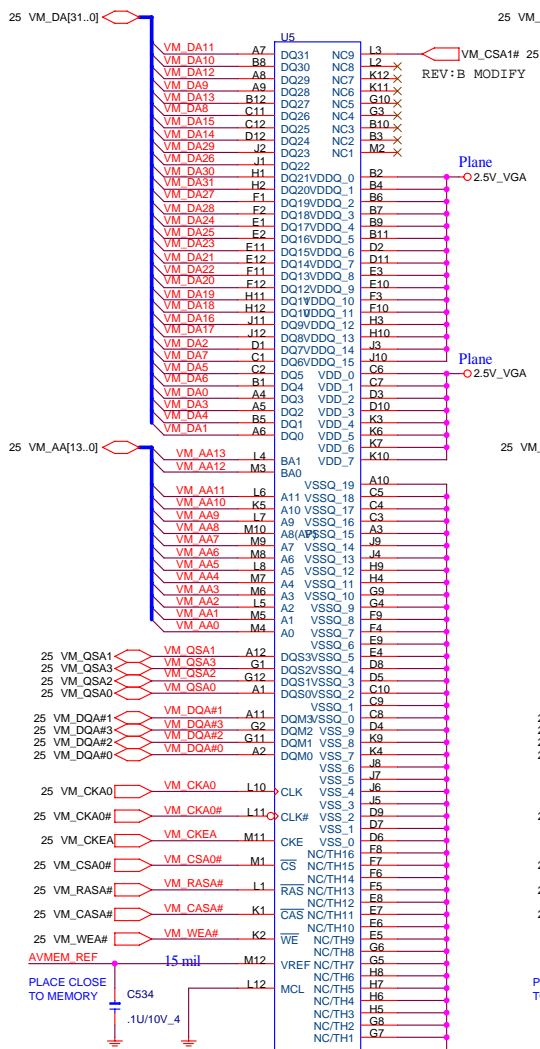

4Mx32 or 8Mx32
K4D263238E-GC33

4Mx32 or 8Mx32
K4D263238E-GC33

4Mx32 or 8Mx32
K4D263238E-GC33

4Mx32 or 8Mx32
K4D263238E-GC33

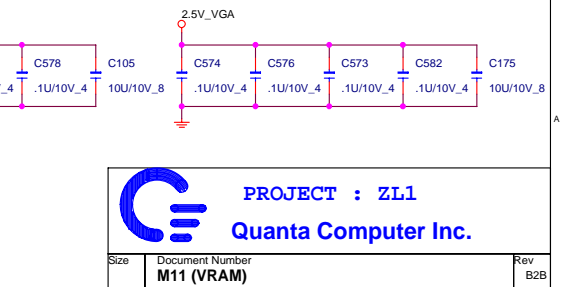
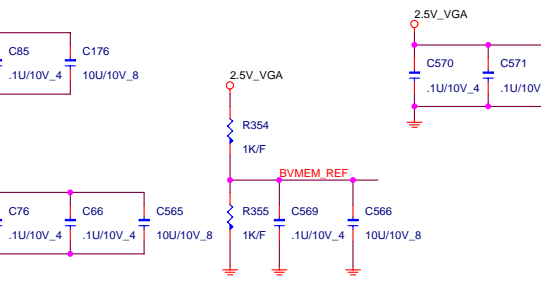
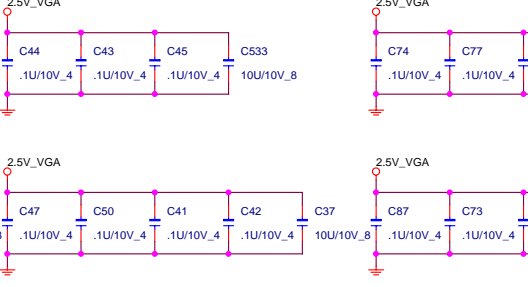
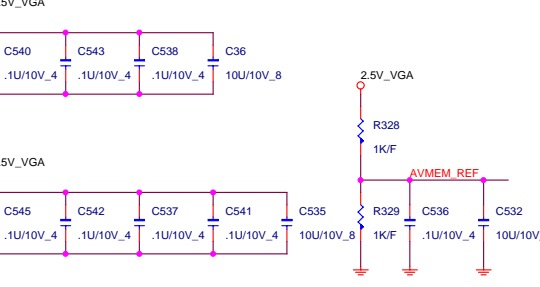

PROJECT : ZL1
Quanta Computer Inc.

Size	Document Number	Rev
	M11 (VRAM)	B2B
Date:	Friday, June 04, 2004	Sheet 27 of 35

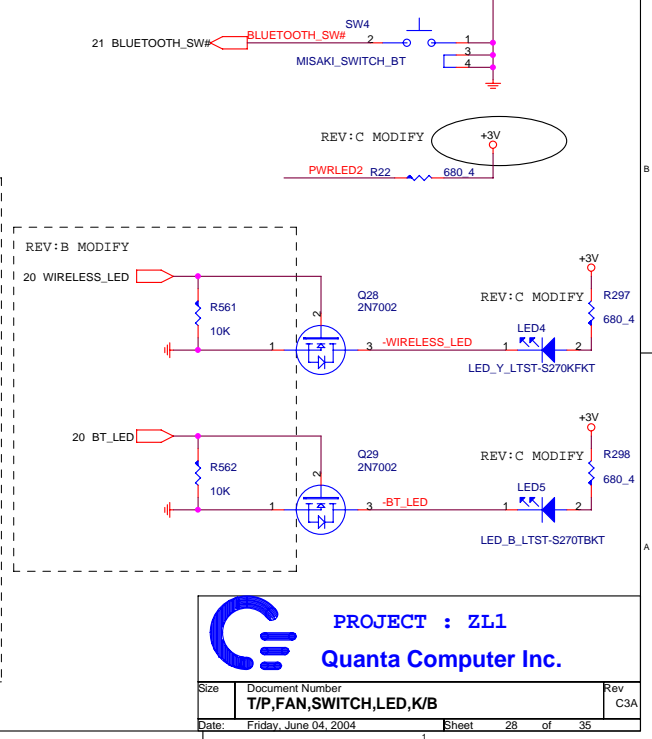
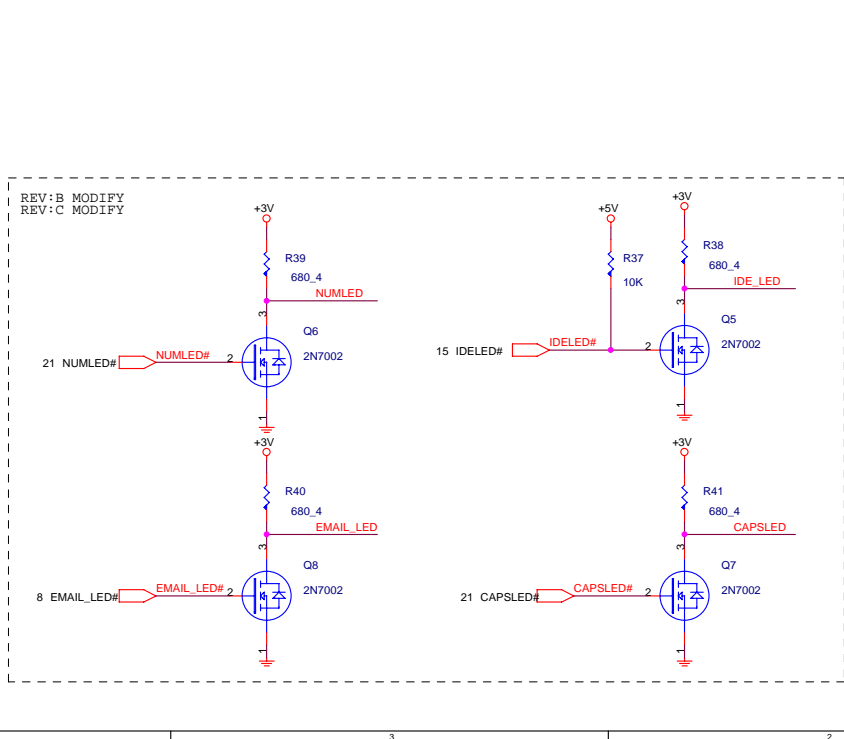
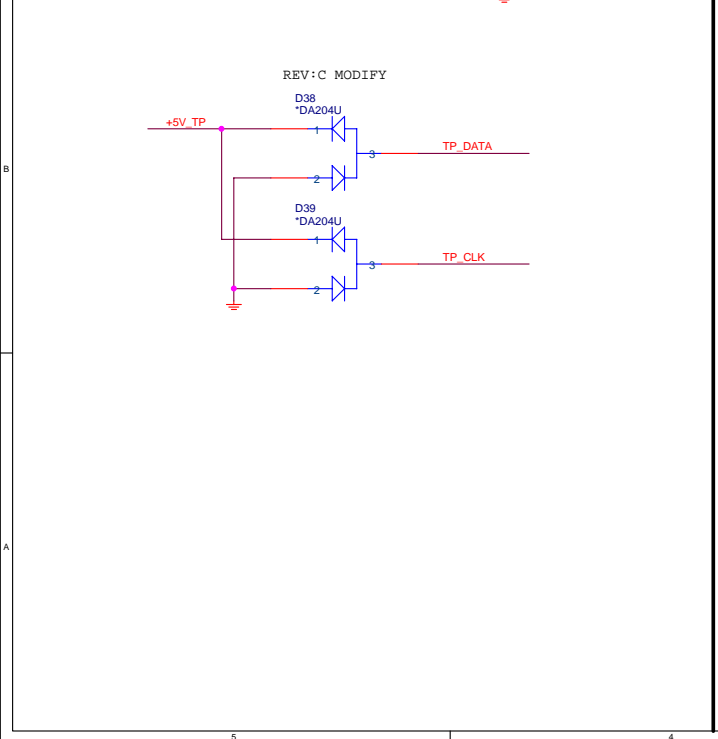
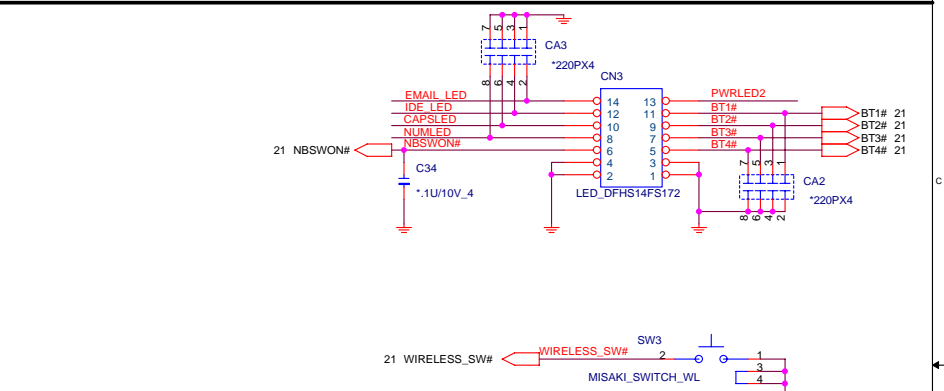
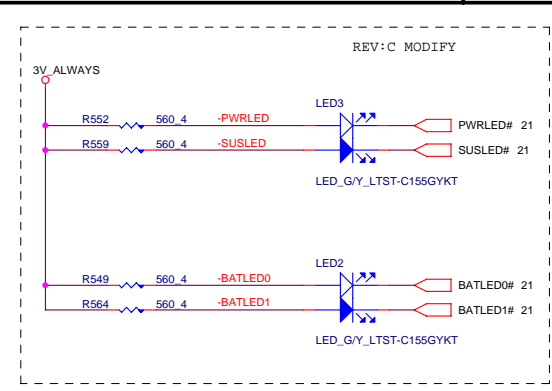
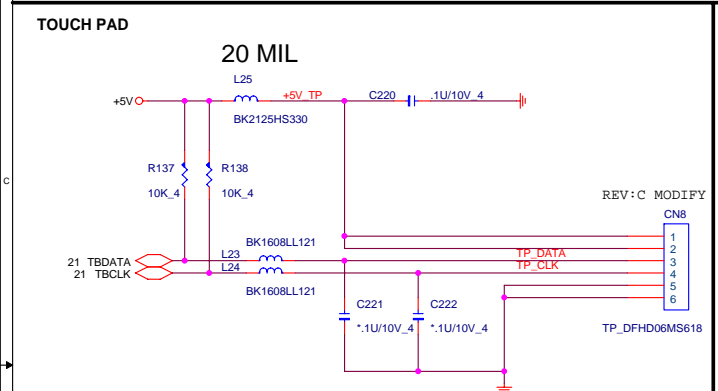
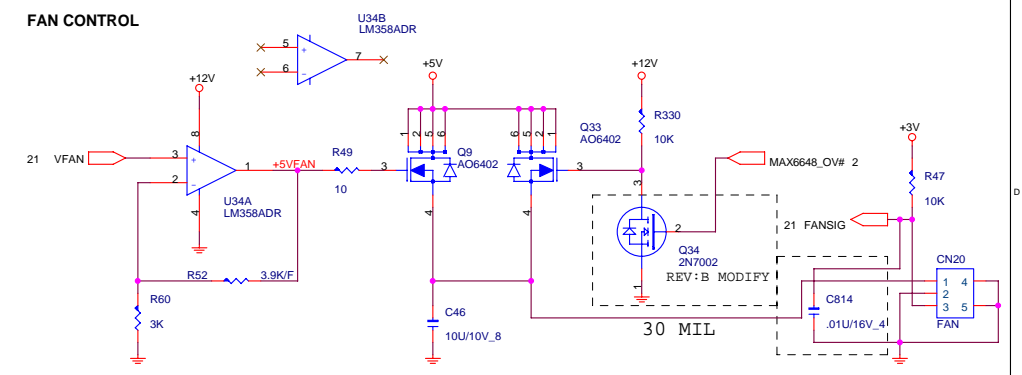
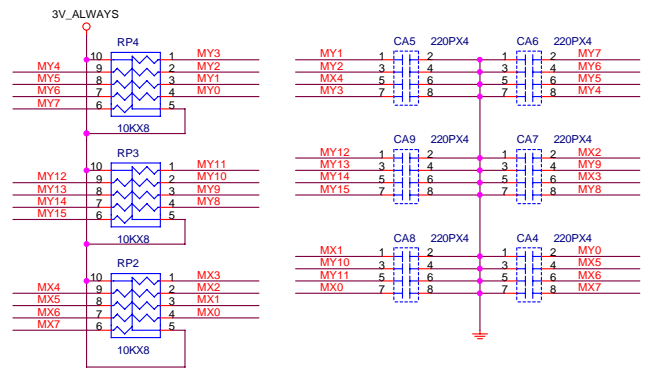
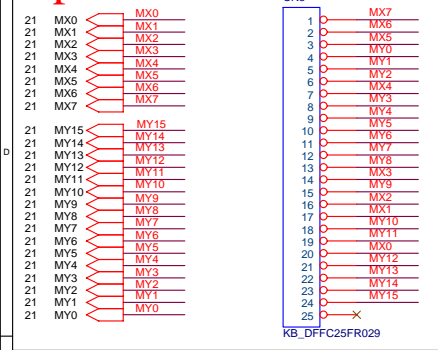

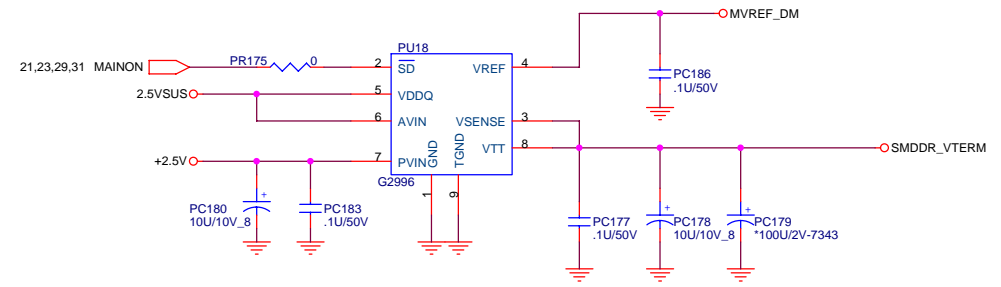
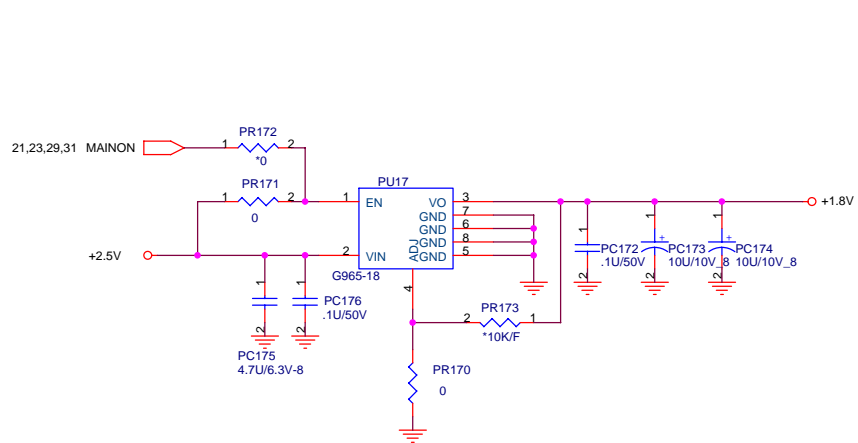
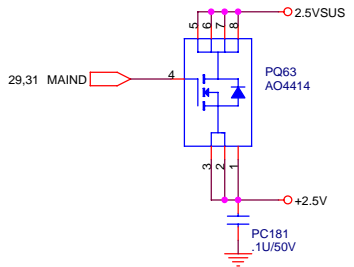
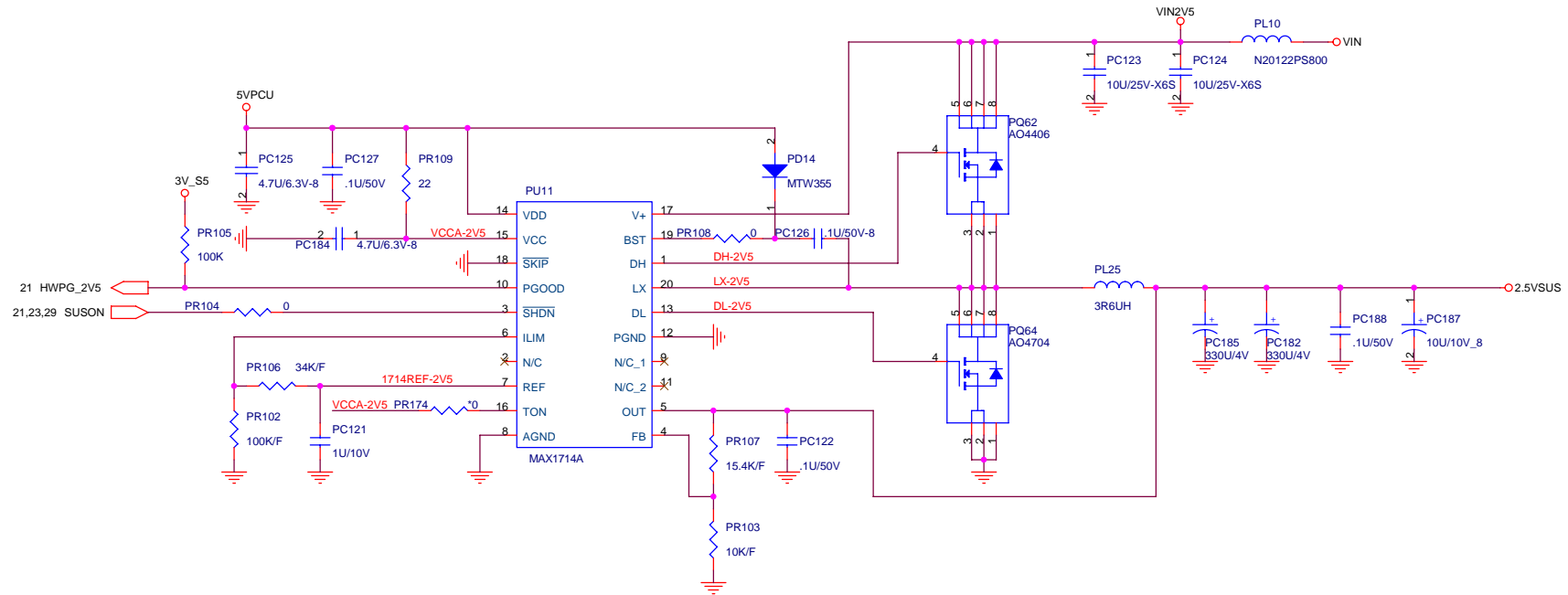

		PROJECT : ZL1	
		Quanta Computer Inc.	
Size	Document Number	Rev	
	2.5VSUS / +1.25TERM	A1A	
Date:	Friday, June 04, 2004	Sheet	30 of 35

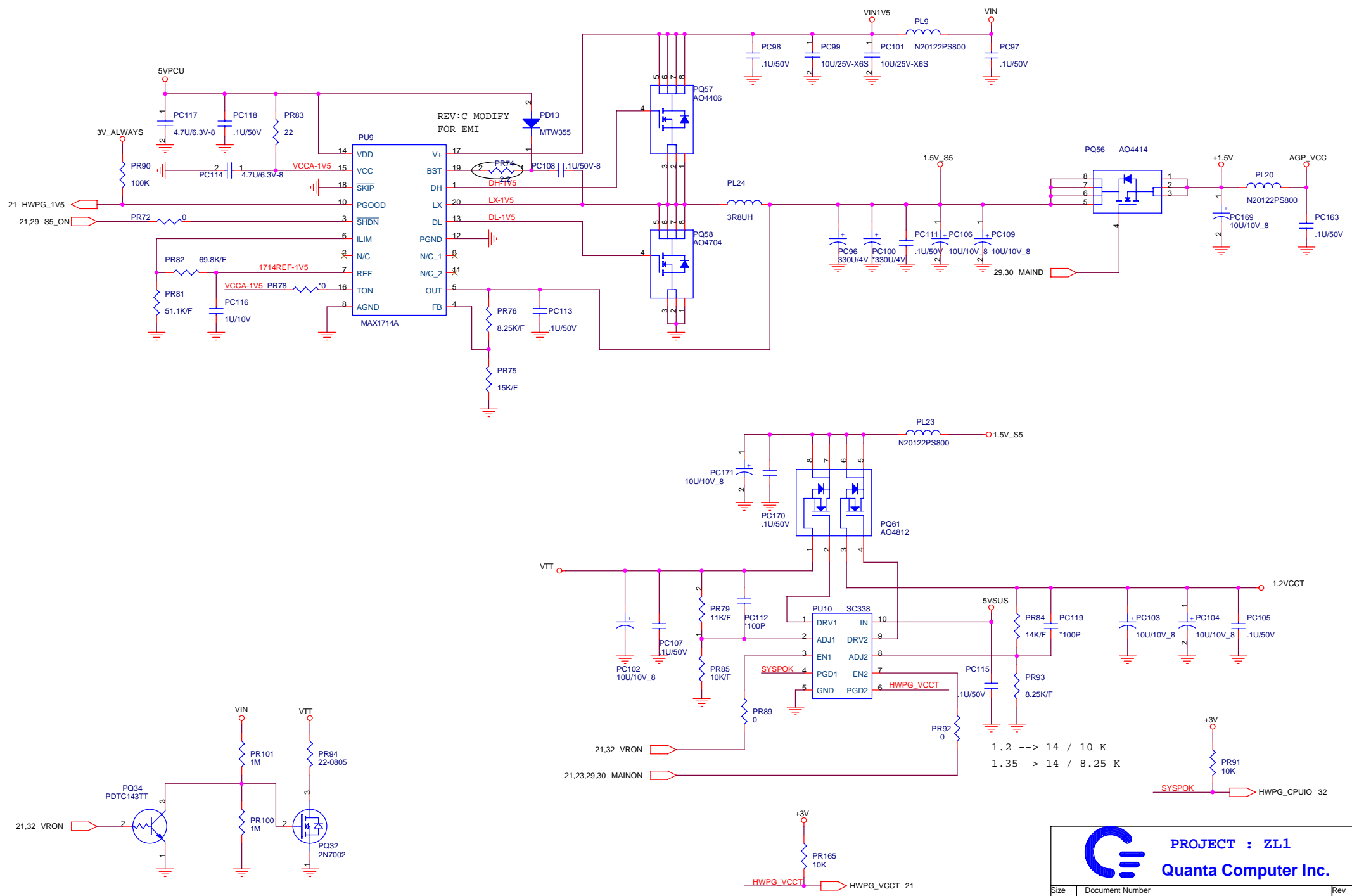

PROJECT : ZL1
Quanta Computer Inc.

Size	Document Number	Rev
	+1.5 / CPUIO	C3A
Date:	Friday, June 04, 2004	Sheet 31 of 35

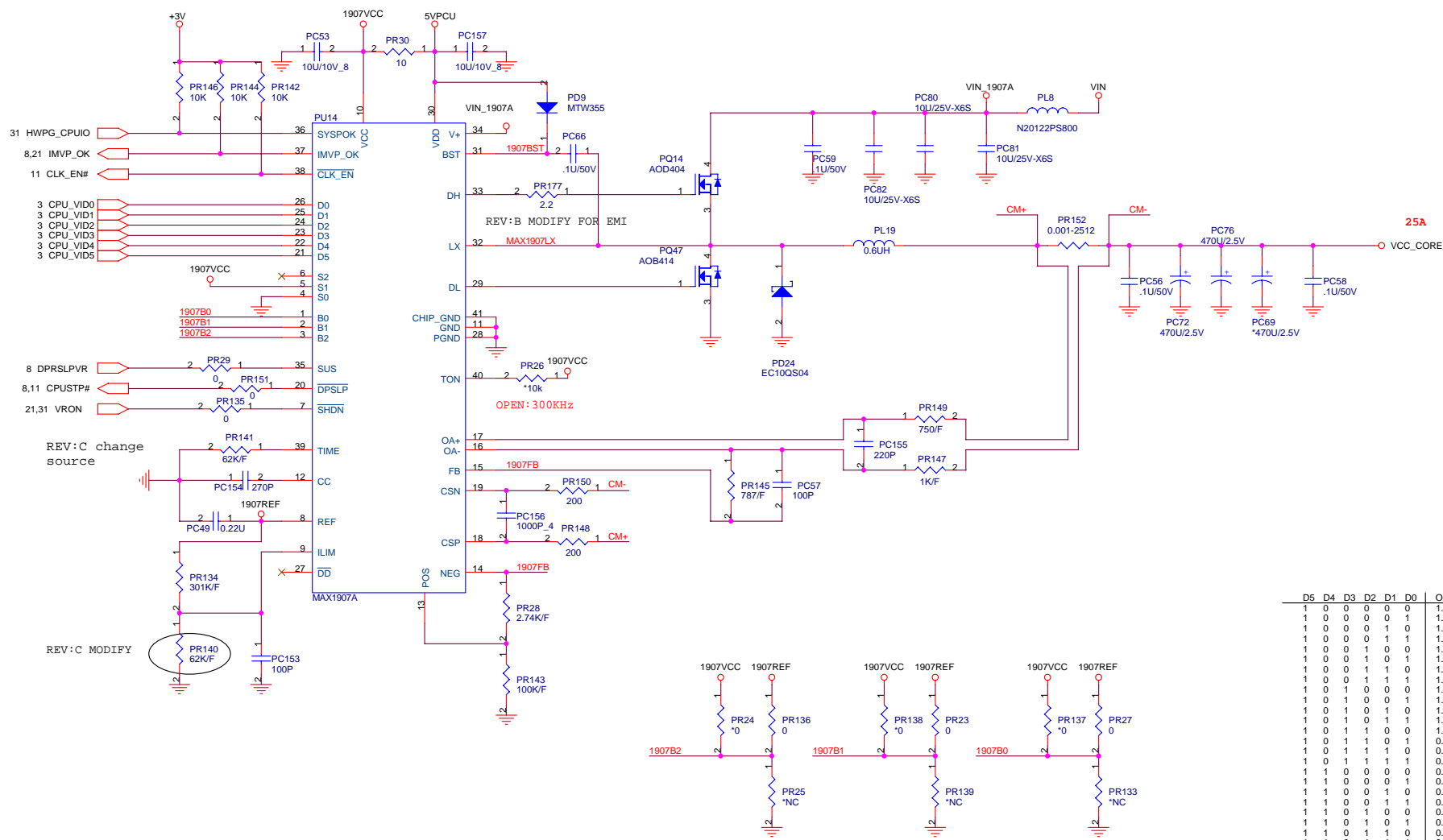

D5	D4	D3	D2	D1	D0	Output	D5	D4	D3	D2	D1	D0	Output
1	0	0	0	0	0	1.196V	0	0	0	0	0	0	1.708V
1	0	0	0	0	1	1.180V	0	0	0	0	0	1	1.692V
1	0	0	0	1	0	1.184V	0	0	0	0	0	1	1.676V
1	0	0	0	1	1	1.148V	0	0	0	0	1	1	1.660V
1	0	0	1	0	0	1.132V	0	0	0	1	0	0	1.644V
1	0	0	1	0	1	1.116V	0	0	0	1	0	1	1.628V
1	0	0	1	1	0	1.100V	0	0	0	1	1	0	1.612V
1	0	1	0	0	0	1.084V	0	0	0	1	1	1	1.596V
1	0	1	0	0	1	1.068V	0	0	1	0	0	0	1.580V
1	0	1	0	1	0	1.052V	0	0	1	0	0	1	1.564V
1	0	1	1	0	0	1.036V	0	0	1	0	1	0	1.548V
1	0	1	1	0	1	1.020V	0	0	1	0	1	1	1.532V
1	0	1	1	1	0	1.004V	0	0	1	1	0	0	1.516V
1	1	0	0	0	0	0.988V	0	0	1	1	0	1	1.500V
1	1	0	0	0	1	0.972V	0	0	1	1	1	0	1.484V
1	1	0	0	1	0	0.956V	0	0	1	1	1	1	1.468V
1	1	0	0	1	1	0.940V	0	1	0	0	0	0	1.452V
1	1	0	1	0	0	0.924V	0	1	0	0	0	1	1.436V
1	1	0	1	0	1	0.908V	0	1	0	0	1	0	1.420V
1	1	0	1	1	0	0.892V	0	1	0	0	1	1	1.404V
1	1	0	1	1	1	0.876V	0	1	0	1	0	0	1.388V
1	1	0	1	1	0	0.860V	0	1	0	1	1	0	1.372V
1	1	1	0	0	0	0.844V	0	1	0	1	1	1	1.356V
1	1	1	0	0	1	0.828V	0	1	0	1	1	1	1.340V
1	1	1	0	1	0	0.812V	0	1	1	0	0	0	1.324V
1	1	1	0	1	1	0.796V	0	1	1	0	0	1	1.308V
1	1	1	1	0	0	0.780V	0	1	1	0	1	0	1.292V
1	1	1	1	0	1	0.764V	0	1	1	0	1	1	1.276V
1	1	1	1	1	0	0.748V	0	1	1	1	0	0	1.260V
1	1	1	1	1	1	0.732V	0	1	1	1	0	1	1.244V
1	1	1	1	1	0	0.716V	0	1	1	1	1	0	1.228V
1	1	1	1	1	1	0.700V	0	1	1	1	1	1	1.212V

SUSPEND MODE (SUS=HIGH)

S2	S1	S0	Output	
✓	OPEN	VCC	GND	0.748V

VCC_BOOT

B2	B1	B0	Output	
✓	GND	GND	GND	1.708V
	REF	REF	REF	1.372V
	OPEN	OPEN	OPEN	1.036V
	VCC	VCC	VCC	0.700V
	REF	VCC	VCC	1.212V

PROJECT : ZL1
Quanta Computer Inc.

Size	Document Number	Rev
	CPU CORE (MAX1907)	C3A
Date:	Friday, June 04, 2004	Sheet 32 of 35

1ST_BATT_CONN

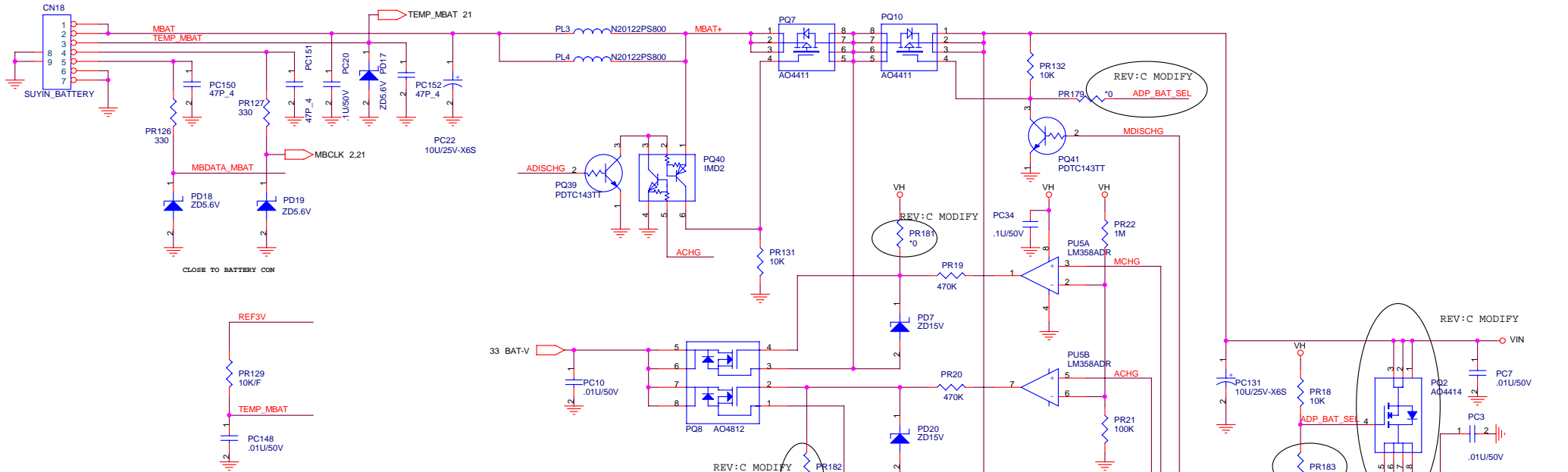

2ND_BATT_CONN

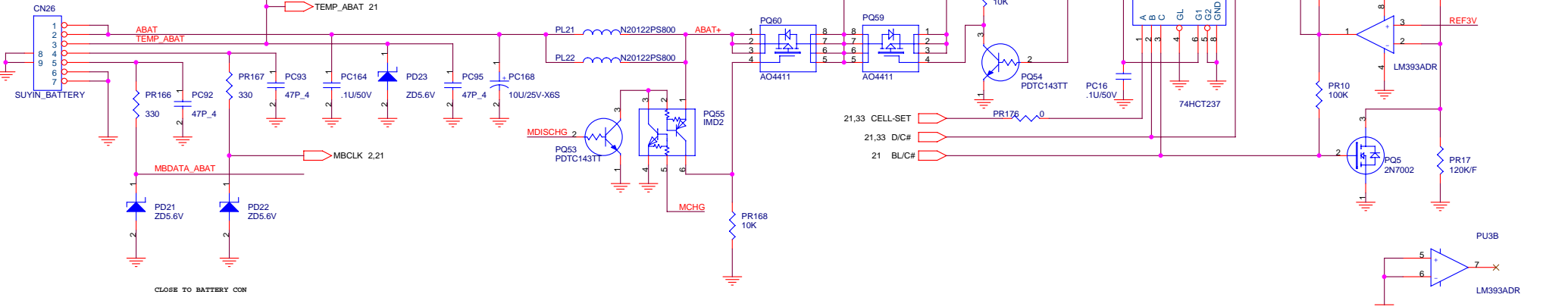

1ST_BATT

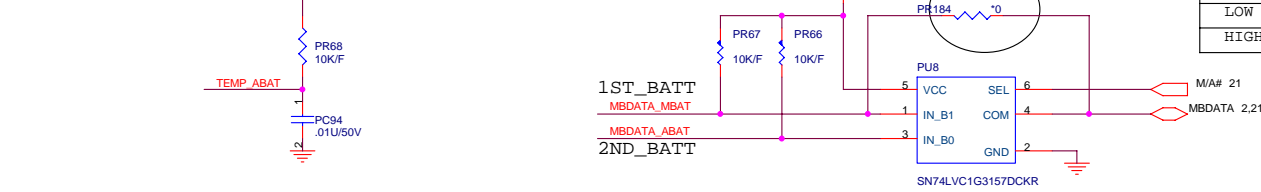

SEL	FUNCTION
LOW	IN_B0
HIGH	IN_B1

PROJECT : ZL1
Quanta Computer Inc.

Size: Document Number
BATTERY SELECT
 Rev: C3A

Date: Friday, June 04, 2004 Sheet 34 of 35

MODEL	REV	CHANGE LIST	PAGE	FROM	TO
ZL1 MotherBoard	B2B	PAGE2 . 1.UN-STUFF R392 FOR THERMTRIP 2. STUFF NUTS	1	A1A	
		PAGE5 . 1.ADD +3V FOR LCD EDID 2.MODIFY C528 VALUE	2	B2B	C3A
		PAGE8 . 1.STUFF R204 FOR THERMTRIPS	3	A1A	
		PAGE12 . 1.ADD 10/100 CO LAYOUT CIRCUIT	4	A1A	
		PAGE13 . 1.ADD PR_INSERT# FOR SYSTEM CIRCUIT 2.MODIFY LAN SWITCH POWER	5	B2B	
		PAGE14 . 1.ADD PR_INSERT# FOR SYSTEM CIRCUIT	6	A1A	
		PAGE15 . 1.ADD RBAYID1 PULL DOWN RESISTOR	7	A1A	
		PAGE18 . 1.MODIFY FOR AUDIO QUALITY	8	B2B	
		PAGE19 . 1.MODIFY FOR AUDIO QUALITY	9	A1A	
		PAGE20 . 1.ADD EMI SOLUTION	10	A1A	
C3A		PAGE22 . 1.MODIFY PR_INSERT# PULL HIGH VOLTAGE	11	A1A	C3A
		PAGE23 . 1.STUFF PC45 FOR VGA CORE 2. MODIFY 2.5V_VGA POWER	12	B2B	C3A
		PAGE24 . 1.MODIFY GPAR PULL HIGH RESISTOR 2. ADD PULL HIGH FOR I2C BUS	13	B2B	C3A
		PAGE27 . 1.MODIFY CS PIN FOR 128MB VRAM	14	B2B	C3A
		PAGE28 . 1.MODIFY LED CIRCUIT 2. MODIFY Q34 TO 2N7002	15	B2B	
		PAGE29 . 1.MODIFY MAX6648 OV# CIRCUIT	16	A1A	C3A
		PAGE32 . 1.MODIFY CPU CORE VOLTAGE LEVEL	17	A1A	C3A
		PAGE33 . 1.MODIFY CHARGER CIRCUIT	18	B2B	C3A
		PAGE34 . 1.MODIFY CHARGER CIRCUIT	19	B2B	C3A
		PAGE02 . 1.MODIFY MAX6648 AL# TO HIGH ACTIVE	20	B2B	C3A
		PAGE11 . 1.MODIFY FOR SIGNAL QUALITY	21	A1A	C3A
		PAGE12 . 1.MODIFY LAN LED 2. MODIFY LAN TRACE PULL HIGH	22	B2B	C3A
		PAGE13 . 1.MODIFY LAN LED 2. MODIFY DVO_AVDD	23	B2B	C3A
		PAGE14 . 1.MODIFY RGB BEAD VALUE	24	B2B	C3A
		PAGE16 . 1.REMOVE COMMON MODE CHOKE	25	A1A	
		PAGE17 . 1.MODIFY 3 IN 1 CARD READER FOOTPRINT	26	A1A	
		PAGE18 . 1.MODIFY LINE IN SIGNAL	27	B2B	
		PAGE19 . 1.MODIFY LINE IN SIGNAL	28	B2B	C3A
		PAGE20 . 1.MODIFY USE COMMON MODE CHOKE 2. MODIFY MINI-PCI 3V_S5 TO 3VSUS	29	B2B	C3A
		PAGE21 . 1.MODIFY 97551 PN 21	30	A1A	C3A
		PAGE22 . 1.MODIFY U30 PIN23 TO +5V	31	A1A	C3A
		PAGE23 . 1.MODIFY FOR EMI SOLUTION	32	B2B	C3A
		PAGE24 . 1.ADD EMI SOLUTION	33	B2B	
		PAGE28 . 1.MODIFY PWRLED2 TO +3V 2. ADD TP ESD PROTECT 3. MODIFY LED CIRCUIT	34	B2B	C3A
		PAGE29 . 1.MODIFY FOR POWER SUHTDOWN ISSUE	35	B2B	C3A
PAGE31 . 1.MODIFY FOR EMI SOLUTION					
PAGE32 . 1.CHANGE SOURCE					
PAGE34 . 1.MODIFY CHARGER CIRCUIT FOR COST DOWN					

 PROJECT : ZL1
Quanta Computer Inc.

Size Document Number Rev
CHANGE LIST C3A

Date: Friday, June 04, 2004 Sheet 35 of 35

PROJECT : ZL1	APPROVE BY: JIM HSU	DRAWING BY:JACKY CHENG	REV C3A	COVER SHEET 1 OF 1
MB ASSY'S P/N : 31ZL1MB0004	PROJECT LEADER: JIM HSU	DOCUMENT NO: 204	DATE :2004/06/01	