

HM40-MV Block Diagram

Project code: 91.4BW01.001
 PCB P/N : 48.4BW01.0SB
 REVISION : 08242-SB

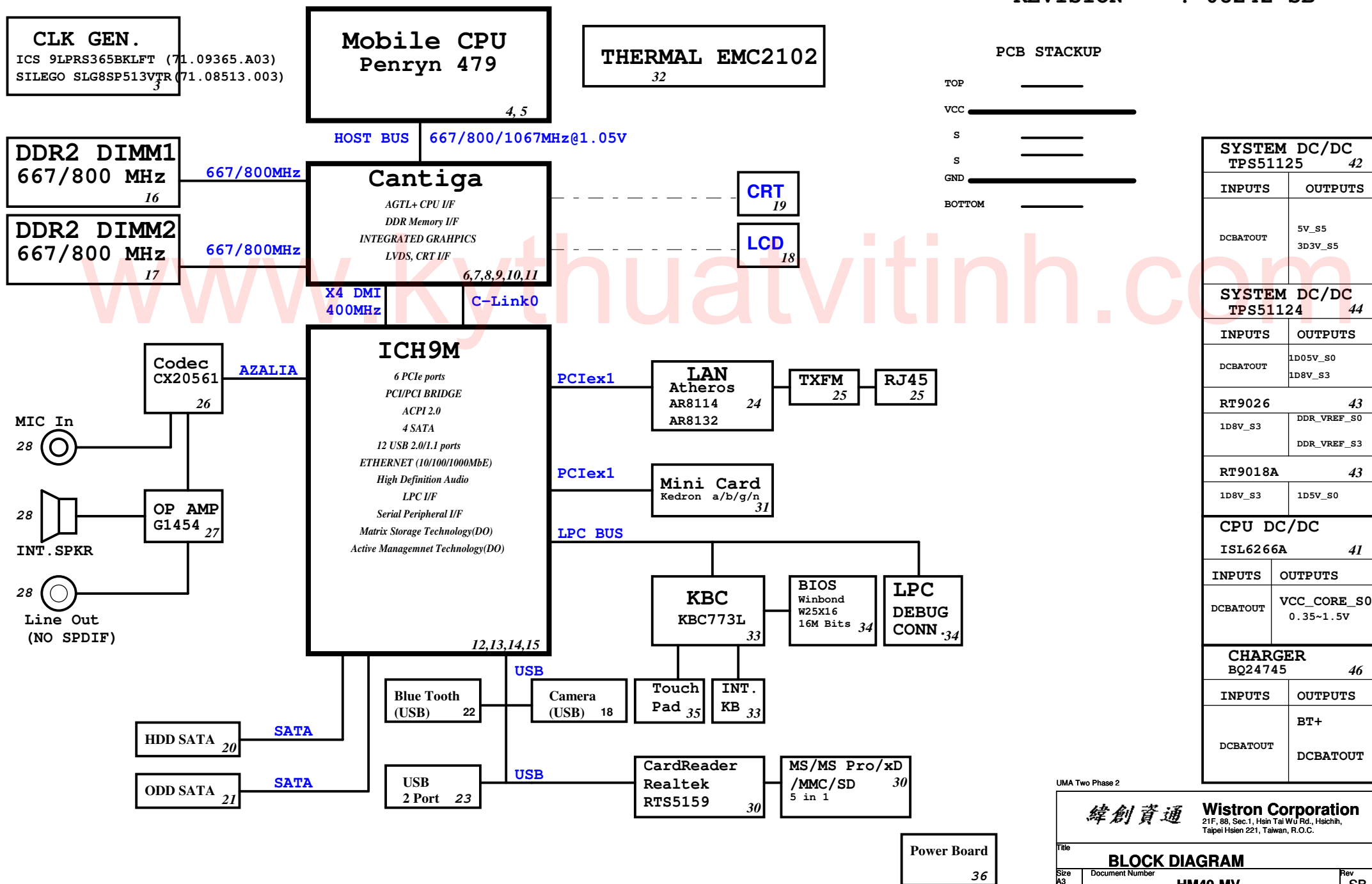

SYSTEM DC/DC TPS51125 42	
INPUTS	OUTPUTS
DCBATOUT	5V_S5 3D3V_S5
SYSTEM DC/DC TPS51124 44	
INPUTS	OUTPUTS
DCBATOUT	1D05V_S0 1D8V_S3
RT9026	43
1D8V_S3	DDR_VREF_S0 DDR_VREF_S3
RT9018A	43
1D8V_S3	1D5V_S0
CPU DC/DC ISL6266A 41	
INPUTS	OUTPUTS
DCBATOUT	VCC_CORE_S0 0.35~1.5V
CHARGER BQ24745 46	
INPUTS	OUTPUTS
DCBATOUT	BT+ DCBATOUT

UMA Two Phase 2

緯創資通 Wistron Corporation
 21F, 88, Sec.1, Hsin Tai Wu Rd., Hsichih,
 Taipei Hsien 221, Taiwan, R.O.C.

Title: **BLOCK DIAGRAM**

Size A3 Document Number **HM40-MV** Rev SB

Date: Monday, November 24, 2008 Sheet 1 of 51

Signal	Usage/When Sampled	Comment
HDA_SDOUT	XOR Chain Entrance/PCIE Port Config1 bit1, Rising Edge of PWROK	Allows entrance to XOR Chain testing when TP3 pulled low. When TP3 not pulled low at rising edge of PWROK, sets bit1 of RPC.PC(Config Registers: offset 224h). This signal has weak internal pull-down
HDA_SYNC	PCIE config1 bit0, Rising Edge of PWROK.	This signal has a weak internal pull-down. Sets bit0 of RPC.PC(Config Registers:Offset 224h)
GNT2#/GPIO53	PCIE config2 bit2, Rising Edge of PWROK.	This signal has a weak internal pull-up. Sets bit2 of RPC.PC2(Config Registers:Offset 0224h)
GPIO20	Reserved	This signal should not be pulled high.
GNT1#/GPIO51	ESI Strap (Server Only) Rising Edge of PWROK	ESI compatible mode is for server platforms only. This signal should not be pulled low for desktop and mobile.
GNT3#/GPIO55	Top-Block Swap Override. Rising Edge of PWROK.	Sampled low:Top-Block Swap mode(inverts A16 for all cycles targeting FWH BIOS space). Note: Software will not be able to clear the Top-Swap bit until the system is rebooted without GNT3# being pulled down.
GNT0#:SPI_CS1#/GPIO58	Boot BIOS Destination Selection 0:1. Rising Edge of PWROK.	Controllable via Boot BIOS Destination bit (Config Registers:Offset 3410h:bit 11:10). GNT0# is MSB, 01-SPI, 10-PCI, 11-LPC.
SPI_MOSI	Integrated TPM Enable, Rising Edge of CLPWROK	Sample low: the Integrated TPM will be disabled. Sample high: the MCH TPM enable strap is sampled low and the TPM Disable bit is clear, the Integrated TPM will be enable.
GPIO49	DMI Termination Voltage, Rising Edge of PWROK.	The signal is required to be low for desktop applications and required to be high for mobile applications.
SATALED#	PCI Express Lane Reversal. Rising Edge of PWROK.	Signal has weak internal pull-up. Sets bit 27 of MPC.LR(Device 28:Function 0:Offset D8)
SPKR	No Reboot. Rising Edge of PWROK.	If sampled high, the system is strapped to the "No Reboot" mode(ICH9 will disable the TCO Timer system reboot feature). The status is readable via the NO REBOOT bit.
TP3	XOR Chain Entrance. Rising Edge of PWROK.	This signal should not be pull low unless using XOR Chain testing.
GPIO33/HDA_DOCK_EN#	Flash Descriptor Security Override Strap Rising Edge of PWROK	Sampled low:the Flash Descriptor Security will be overridden. If high, the security measures will be in effect. This should only be enabled in manufacturing environments using an external pull-up resistor.

SIGNAL	Resistor Type/Value
CL_CLK[1:0]	PULL-UP 20K
CL_DATA[1:0]	PULL-UP 20K
CL_RST0#	PULL-UP 20K
DPRS1PVR/GPIO16	PULL-DOWN 20K
ENERGY_DETECT	PULL-UP 20K
HDA_BIT_CLK	PULL-DOWN 20K
HDA_DOCK_EN#/GPIO33	PULL-UP 20K
HDA_RST#	PULL-DOWN 20K
HDA_SDIN[3:0]	PULL-DOWN 20K
HDA_SDOUT	PULL-DOWN 20K
HDA_SYNC	PULL-DOWN 20K
GLAN_DOCK#	The pull-up or pull-down active when configured for native LAN DOCK# functionality and determined by LAN controller
GNT[3:0]#/GPIO[55, 53, 51]	PULL-UP 20K
GPIO[20]	PULL-DOWN 20K
GPIO[49]	PULL-UP 20K
LDA[3:0]#/FWH[3:0]#	PULL-UP 20K
LAN_RXD[2:0]	PULL-UP 20K
LDRQ[0]	PULL-UP 20K
LDRQ[1]/GPIO23	PULL-UP 20K
PME#	PULL-UP 20K
PWRBTN#	PULL-UP 20K
SATALED#	PULL-UP 15K
SPI_CS1#/GPIO58/CLGPIO6	PULL-UP 20K
SPI_MOSI	PULL-DOWN 20K
SPI_MISO	PULL-UP 20K
SPKR	PULL-DOWN 20K
TACH [3:0]	PULL-UP 20K
TP [3]	PULL-UP 20K
USB[11:0] [P, N]	PULL-DOWN 15K

Pin Name	Strap Description	Configuration
CFG[2:0]	FSB Frequency Select	000 = FSB1067 011 = FSB667 010 = FSB800 others = Reserved
CFG[4:3] CFG8 CFG[15:14] CFG[18:17]	Reserved	
CFG5	DMI x2 Select	0 = DMI x2 1 = DMI x4 (Default)
CFG6	iTPM Host Interface	0 = The iTPM Host Interface is enabled (Note 2) 1 = The iTPM Host Interface is disabled (default)
CFG7	Intel Management engine Crypto strap	0 = Transport Layer Security (TLS) cipher suite with no confidentiality 1 = TLS cipher suite with confidentiality (default)
CFG9	PCIE Graphics Lane	0 = Reverse Lanes, 15->0, 14->1 ect.. 1 = Normal operation (Default): Lane Numbered in order
CFG10	PCIE Loopback enable	0 = Enable (Note 3) 1 = Disabled (default)
CFG[13:12]	XOR/ALL	00 = Reserve 10 = XOR mode Enabled 01 = ALL2 mode Enabled (Note 3) 11 = Disabled (default)
CFG16	FSB Dynamic ODT	0 = Dynamic ODT Disabled 1 = Dynamic ODT Enabled (Default)
CFG19	DMI Lane Reversal	0 = Normal operation (Default): Lane Numbered in order 1 = Reverse Lanes DMI x4 mode [MCH -> ICH]: (3->0, 2->1, 1->2 and 0->3) DMI x2 mode [MCH -> ICH]: (3->0, 2->1)
CFG20	Digital Display Port (SDVO/DP/iHDMI) Concurrent with PCIE	0 = Only Digital Display Port or PCIE is operational (Default) 1 = Digital display Port and PCIE are operating simultaneously via the PEG port
SDVO_CTRLDATA	SDVO Present	0 = No SDVO Card Present (Default) 1 = SDVO Card Present
L_DDC_DATA	Local Flat Panel (LFP) Present	0 = LFP Disabled (Default) 1 = LFP Card Present; PCIE disabled

NOTE:
 1. All strap signals are sampled with respect to the leading edge of the (G)MCH Power OK (PWROK) signal.
 2. iTPM can be disabled by a 'Soft-Strap' option in the Flash-decriptor section of the Firmware. This 'Soft-Strap' is activated only after enabling iTPM via CFG6.
 Only one of the CFG10/CFG12/CFG13 straps can be enabled at any time.

PCIE Routing

LANE1	LAN Atheros AR8114A
LANE2	MiniCard WLAN
LANE3	NC
LANE4	NC
LANE5	NC
LANE6	NC

USB Table

USB	
Pair	Device
0	USB1
1	NC
2	NC
3	MINIC1
4	WEBCAM
5	NC
6	NC
7	Bluetooth
8	NC
9	USB2 (High speed)
10	NC
11	CardReader

SMBus

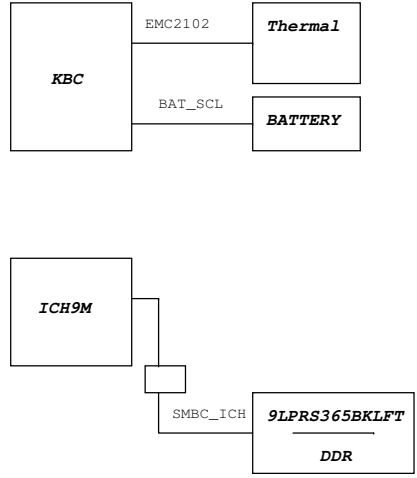

UMA Two Phase 2

緯創資通 Wistron Corporation
 21F, 88, Sec.1, Hsin Tai Wu Rd., Hsichih, Taipei Hsien 221, Taiwan, R.O.C.

Reference

Size A3 Document Number **HM40-MV** Rev **SB**

Date: Monday, November 24, 2008 Sheet 2 of 51

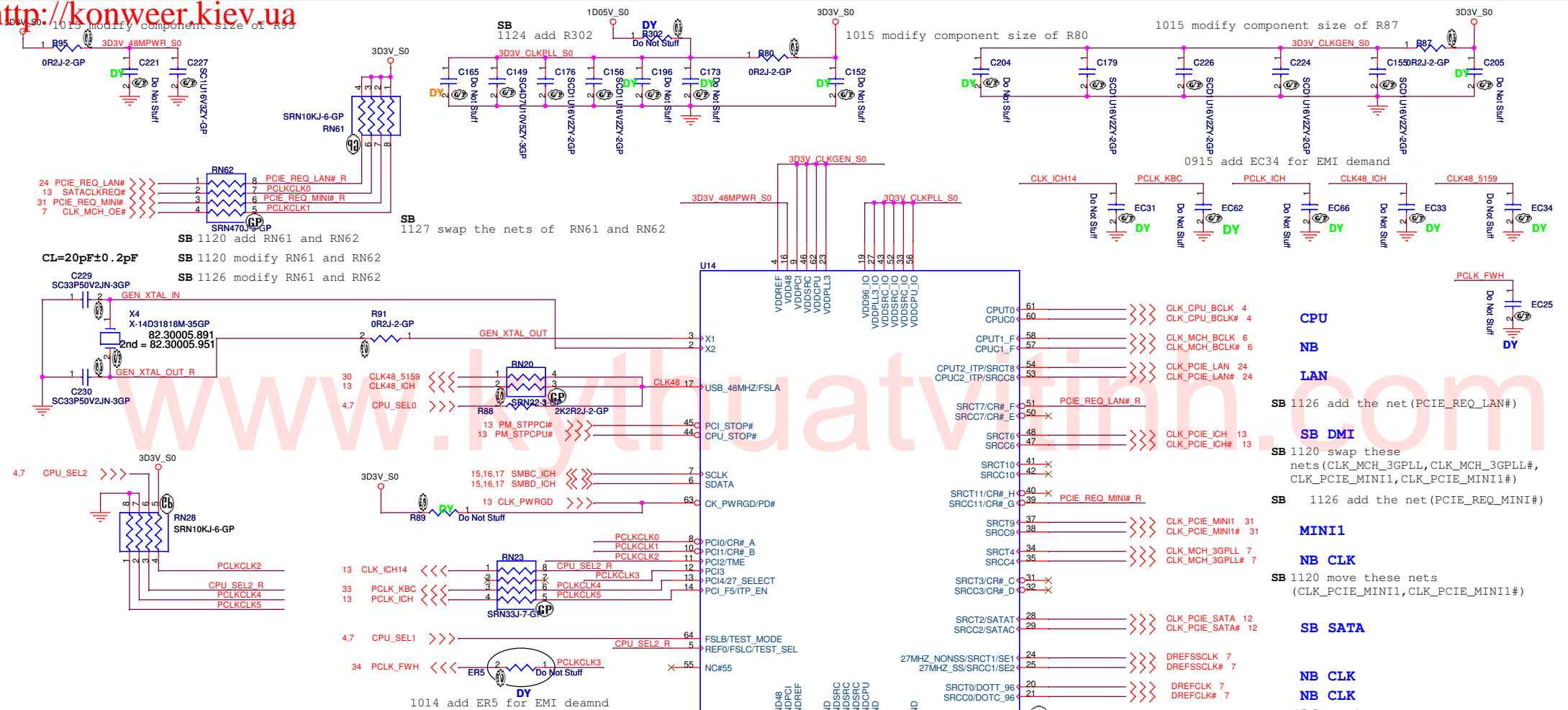

ICS9LPRS365BKLT setting table

PIN NAME	DESCRIPTION
PCI0/CR#_A	Byte 5, bit 7 0 = PCI0 enabled (default) 1 = CR# A enabled. Byte 5, bit 6 controls whether CR#_A controls SRC0 or SRC2 pair Byte 5, bit 6 0 = CR#_A controls SRC2 pair (default), 1 = CR#_A controls SRC0 pair
PCI1/CR#_B	Byte 5, bit 5 0 = PCI1 enabled (default) 1 = CR#_B enabled. Byte 5, bit 6 controls whether CR#_B controls SRC1 or SRC4 pair Byte 5, bit 4 0 = CR#_B controls SRC1 pair (default) 1 = CR#_B controls SRC4 pair
PCI2/TME	0 = Overclocking of CPU and SRC Allowed 1 = Overclocking of CPU and SRC NOT allowed
PCI3	3.3V PCI clock output
PCI4/27M_SEL	0 = Pin24 as SRC-1, Pin25 as SRC-1#, Pin20 as DOT96, Pin21 as DOT96# 1 = Pin24 as 27MHz, Pin25 as 27MHz_SS, Pin20 as SRC-0, Pin21 as SRC-0#
PCI_F5/ITP_EN	0 = SRC8/SRC8# 1 = ITP/ITP#
SRCT3/CR#_C	Byte 5, bit 3 0 = SRC3 enabled (default) 1 = CR#_C enabled. Byte 5, bit 2 controls whether CR#_C controls SRC0 or SRC2 pair Byte 5, bit 2 0 = CR#_C controls SRC0 pair (default), 1 = CR#_C controls SRC2 pair

PIN NAME	DESCRIPTION
SRCC3/CR#_D	Byte 5, bit 1 0 = SRC3 enabled (default) 1 = CR#_D enabled. Byte 5, bit 0 controls whether CR#_D controls SRC1 or SRC4 pair Byte 5, bit 0 0 = CR#_D controls SRC1 pair (default) 1 = CR#_D controls SRC4 pair
SRCC7/CR#_E	Byte 6, bit 7 0 = SRC7# enabled (default) 1 = CR#_F controls SRC6
SRCT7/CR#_F	Byte 6, bit 6 0 = SRC7 enabled (default) 1 = CR#_F controls SRC8
SRCC11/CR#_G	Byte 6, bit 5 0 = SRC11# enabled (default) 1 = CR#_G controls SRC9
SRCT11/CR#_H	Byte 6, bit 4 0 = SRC11 enabled (default) 1 = CR#_H controls SRC10

SEL2	SEL1	SEL0	CPU	FSB
1	0	1	100M	X
0	0	1	133M	533M
0	1	1	166M	667M
0	1	0	200M	800M
0	0	0	266M	1066M

WMA Two Phase 2

緯創資通 Wistron Corporation
21F, 88, Sec.1, Hsin Tai Wu Rd., Hsichih, Taipei Hsien 221, Taiwan, R.O.C.

Title: **Clock Generator**

Size: Document Number **HM40-MV** Rev **SB**

Date: Monday, December 01, 2008 Sheet 3 of 51

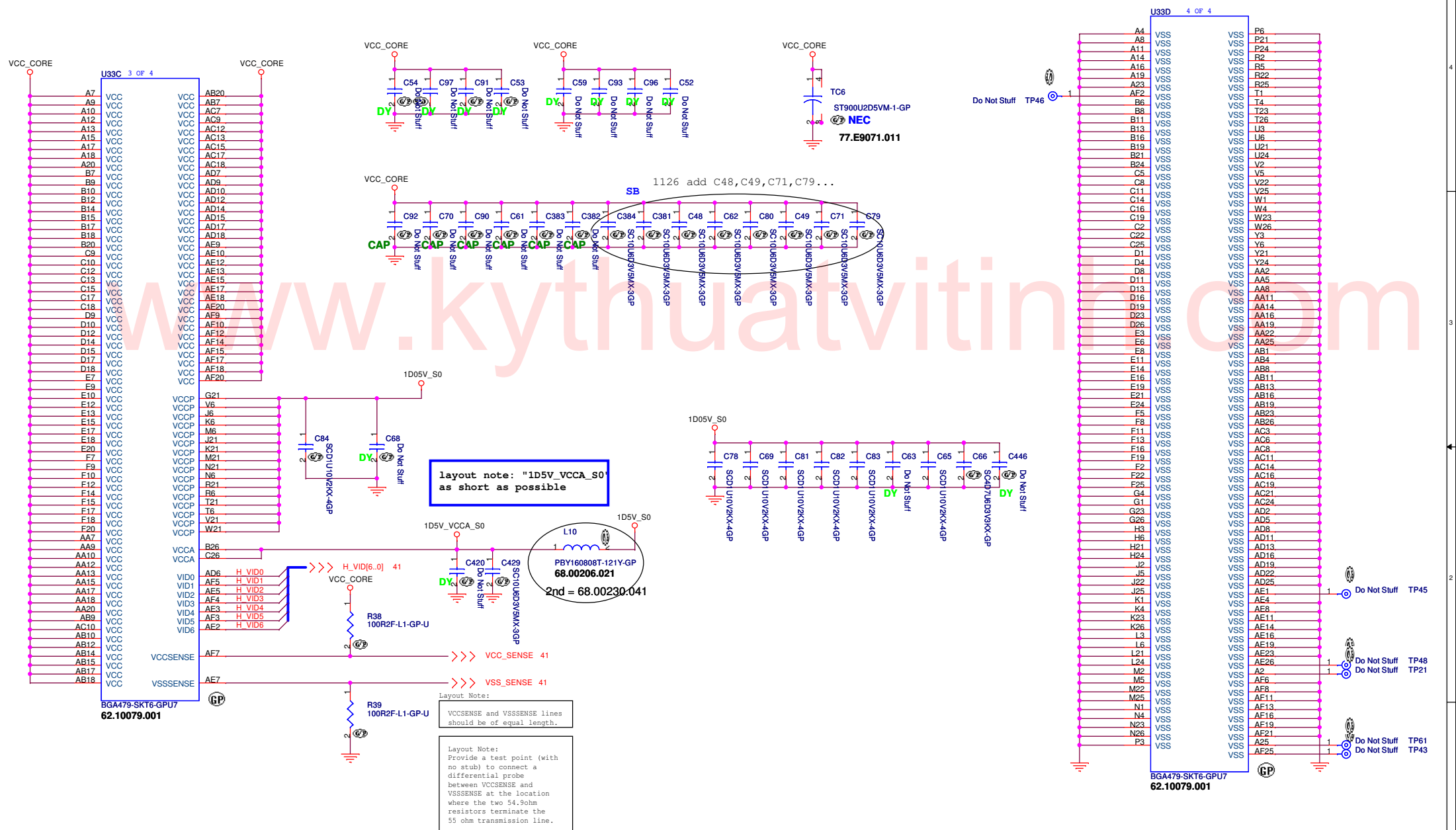

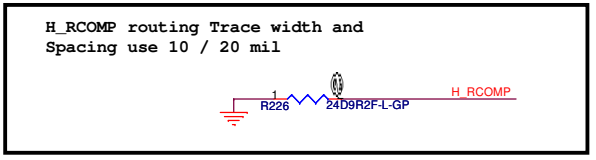
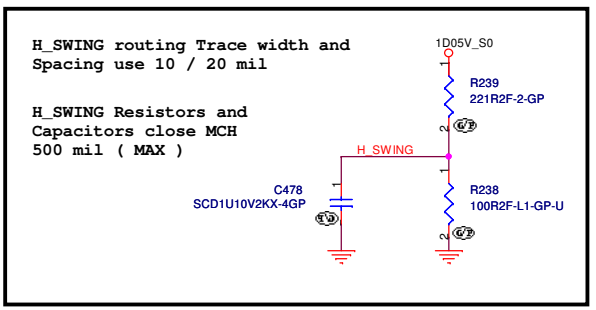

Place them near to the chip (< 0.5")

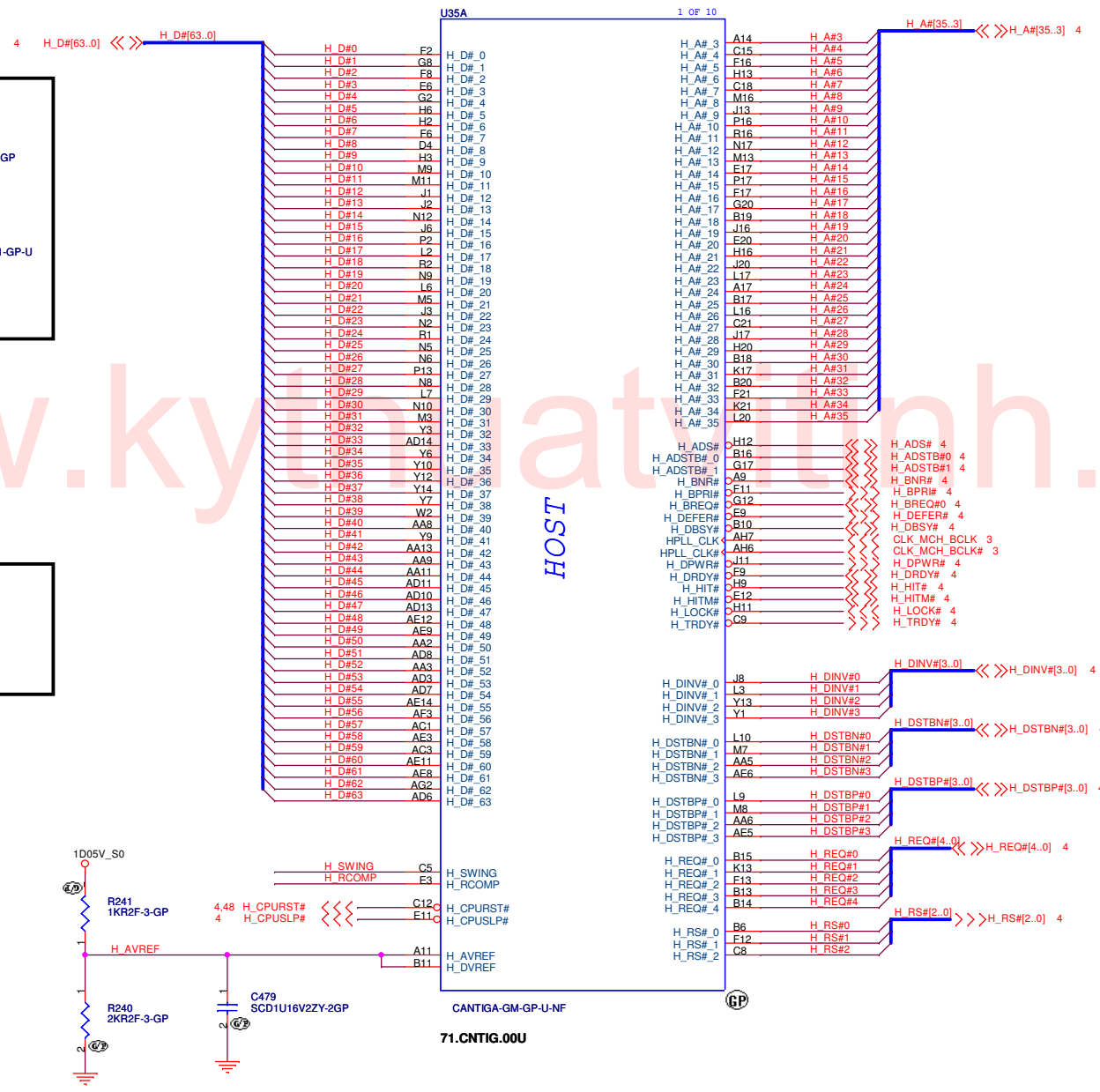

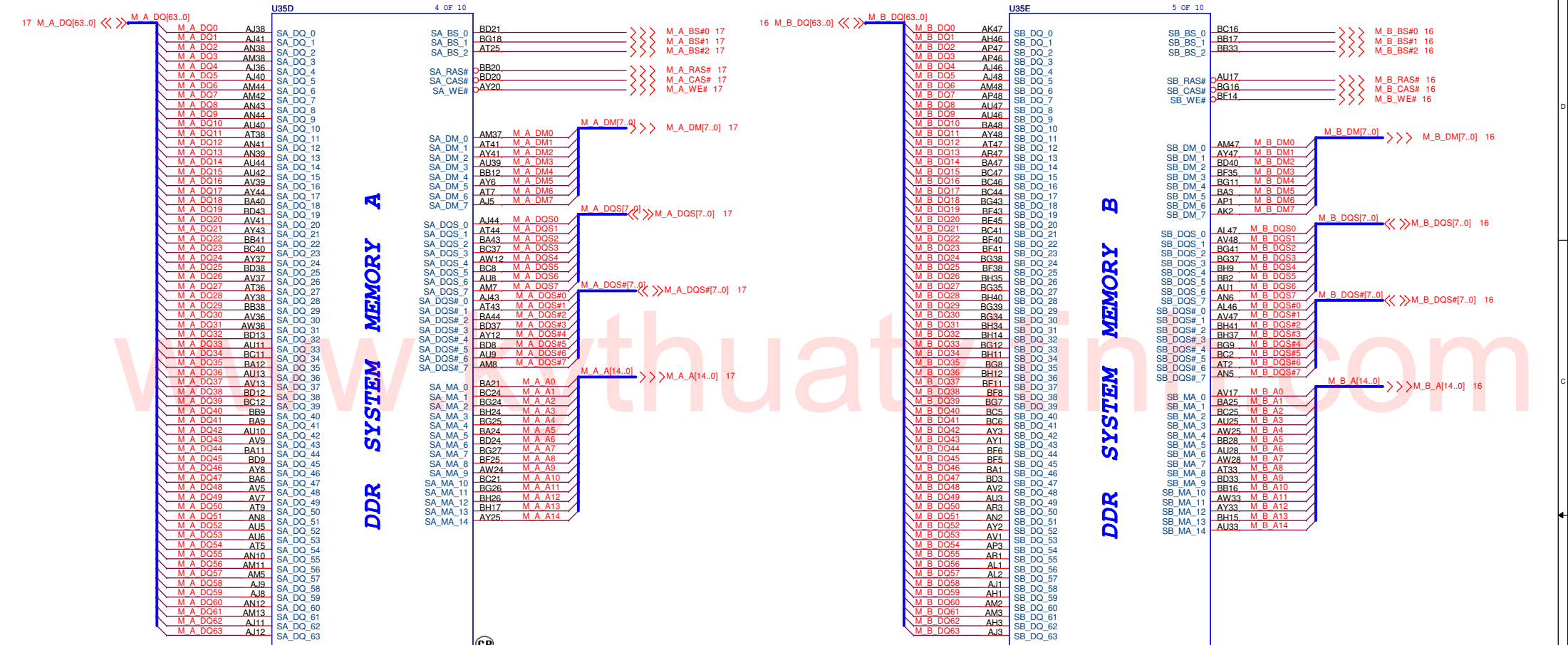

CANTIGA-GM-GP-U-NF
71.CNTIG.000

CANTIGA-GM-GP-U-NF
71.CNTIG.000

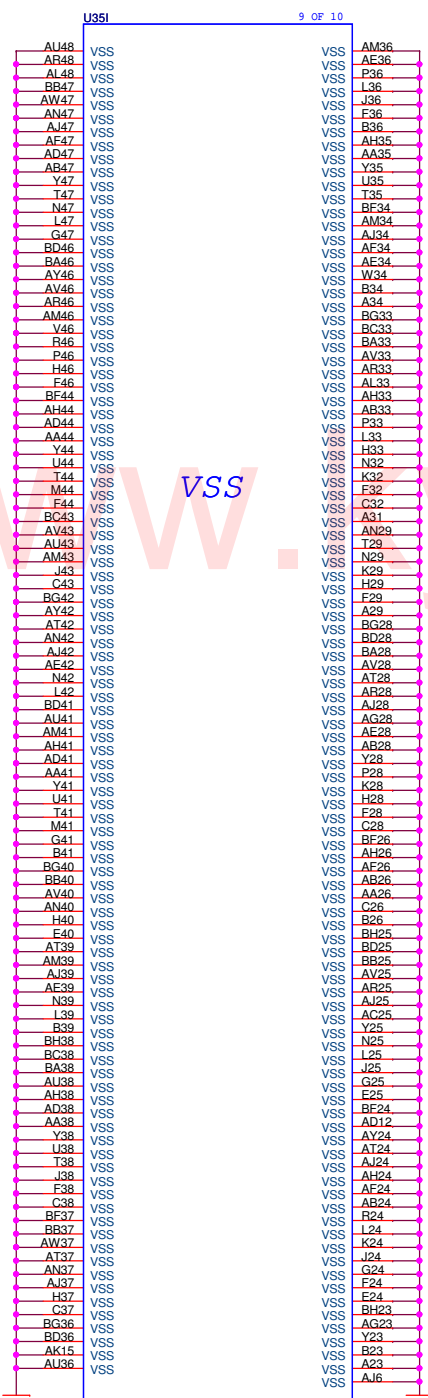

CANTIGA-GM-GP-U-NF
71.CNTIG.00U

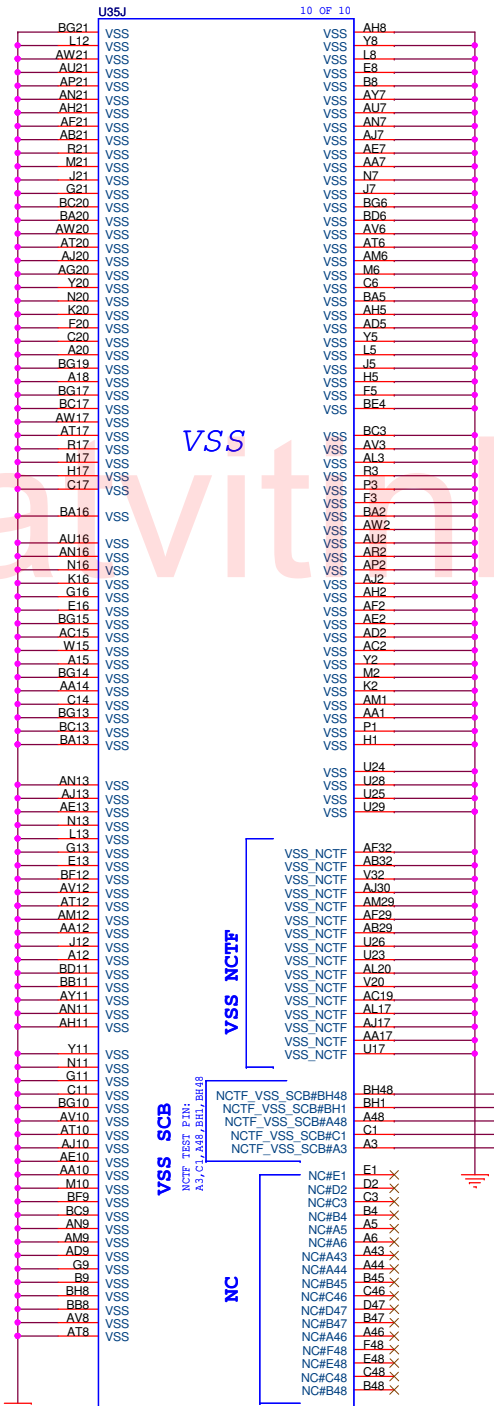

CANTIGA-GM-GP-U-NF
71.CNTIG.00U



緯創資通 Wistron Corporation
21F, 88, Sec. 1, Hsin Tai Wu Rd., Hsichih, Taipei Hsein 221, Taiwan, R.O.C.

Title		Cantiga (6 of 6)	
Size	Document Number	Rev	SB
Date: Monday, December 01, 2008		Sheet	11 of 51

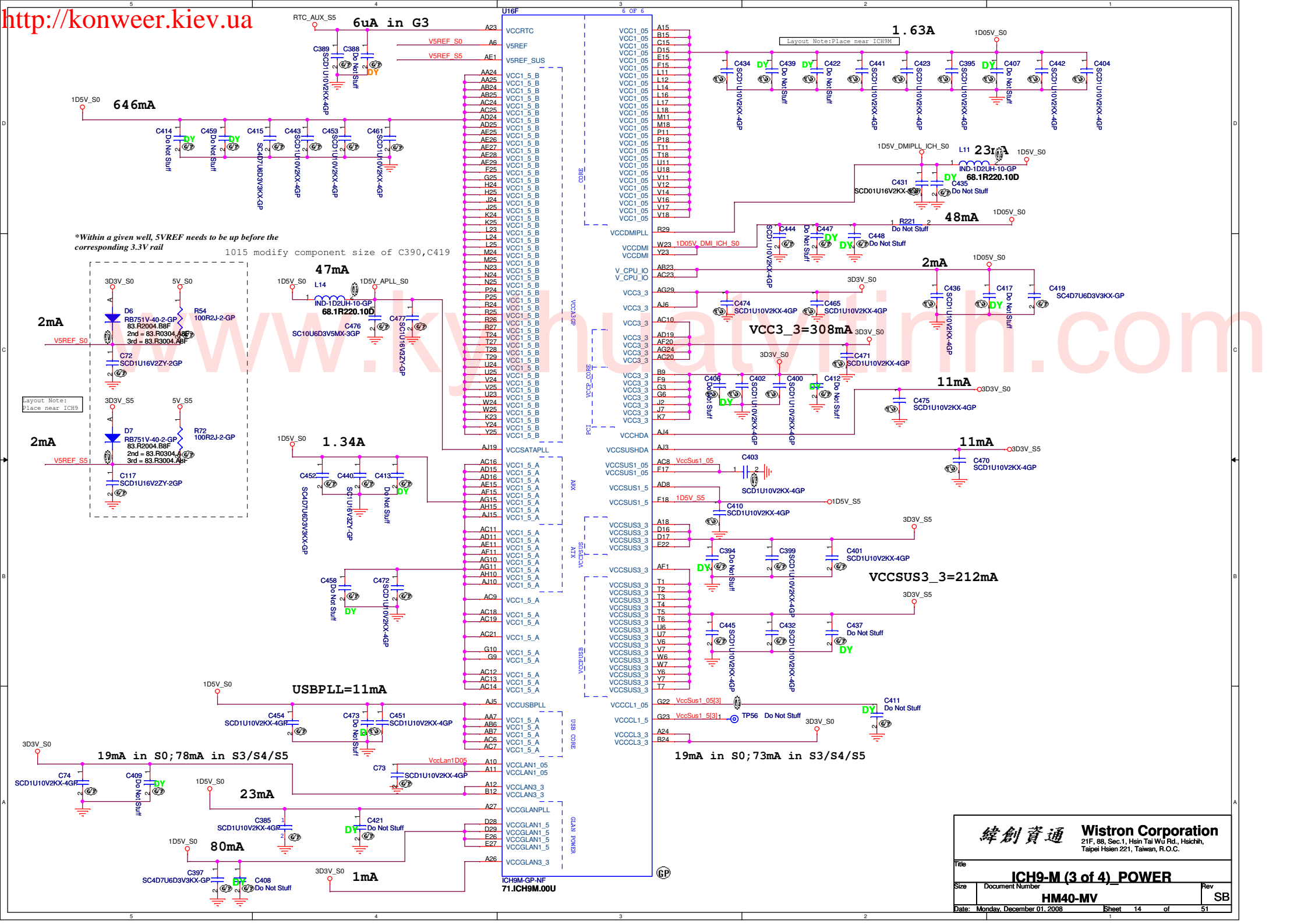

*Within a given well, 5VREF needs to be up before the corresponding 3.3V rail

1015 modify component size of C390,C419

Layout Note:
Place near ICH9

緯創資通 Wistron Corporation
 21F, 88, Sec.1, Hsin Tai Wu Rd., Hsichih, Taipei Hsien 221, Taiwan, R.O.C.

Title: **ICH9-M (3 of 4)_POWER**

Size: Document Number **HM40-MV** Rev: **SB**

Date: Monday, December 01, 2008 Sheet 14 of 51

PARALLEL TERMINATION

Put decap near power(0.9V) and pull-up resistor

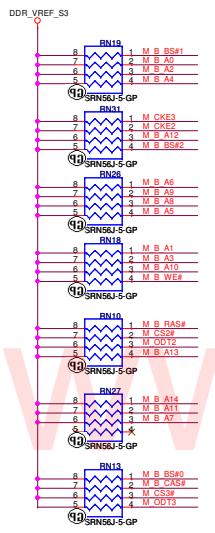

Decoupling Capacitor

Put decap near power(0.9V) and pull-up resistor

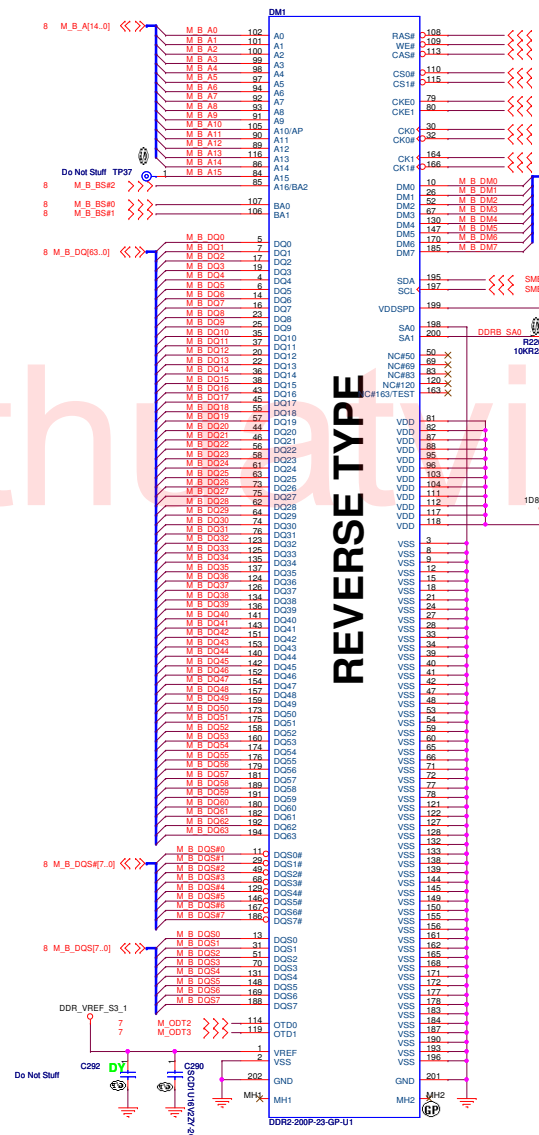
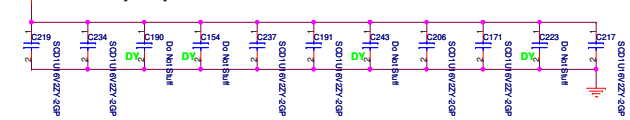

REVERSE TYPE

High 9.2mm
 62.10017.A71
 2nd = 62.10017.B51
 3rd = 62.10017.K51

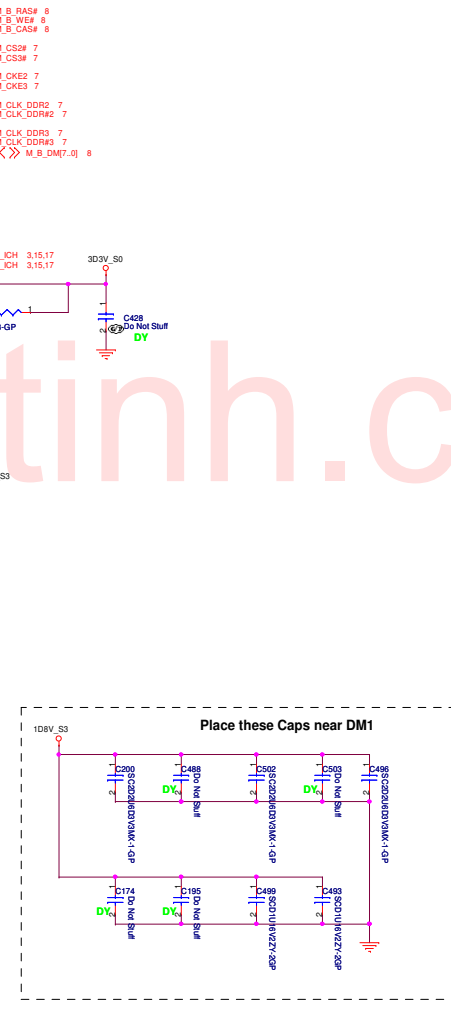

PARALLEL TERMINATION

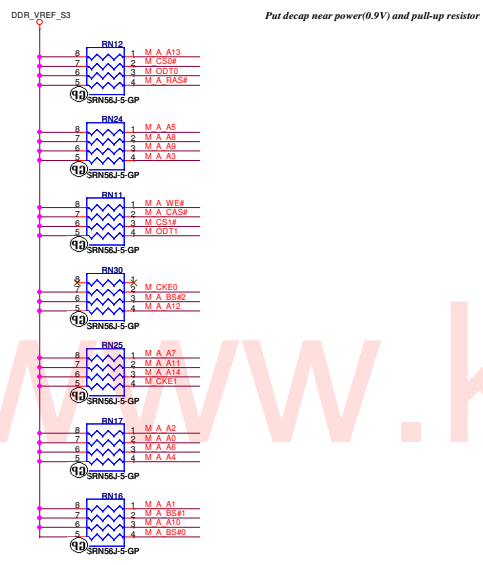

Decoupling Capacitor

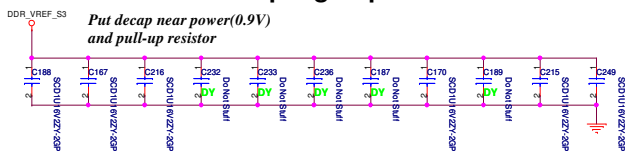

Place these Caps near DM2

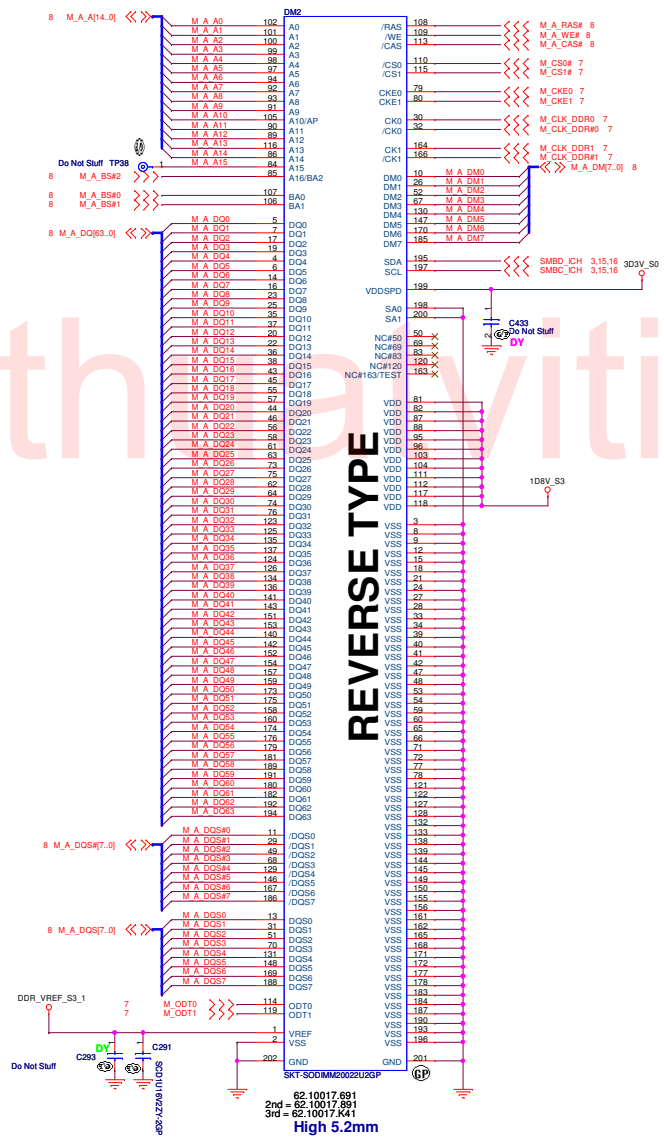
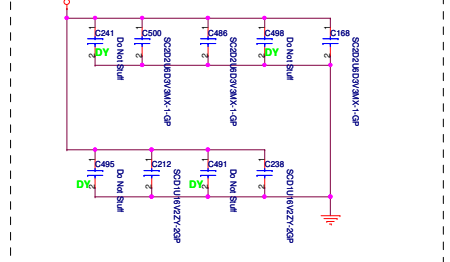

LCD/CCD CONN

- 1015 modify LCD1 pin define
- 1016 modify LCD1 pin define
- 1017 modify USB signal connection
- SB 1121 add EC87 for EMI demand
- SB 1128 modify LCD1

Pin	Symbol
1	CCD_PWR
2	USB-
3	USB+
4	GND
5	GND

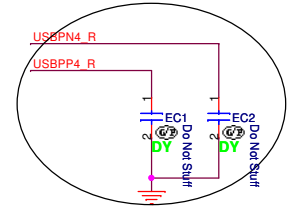
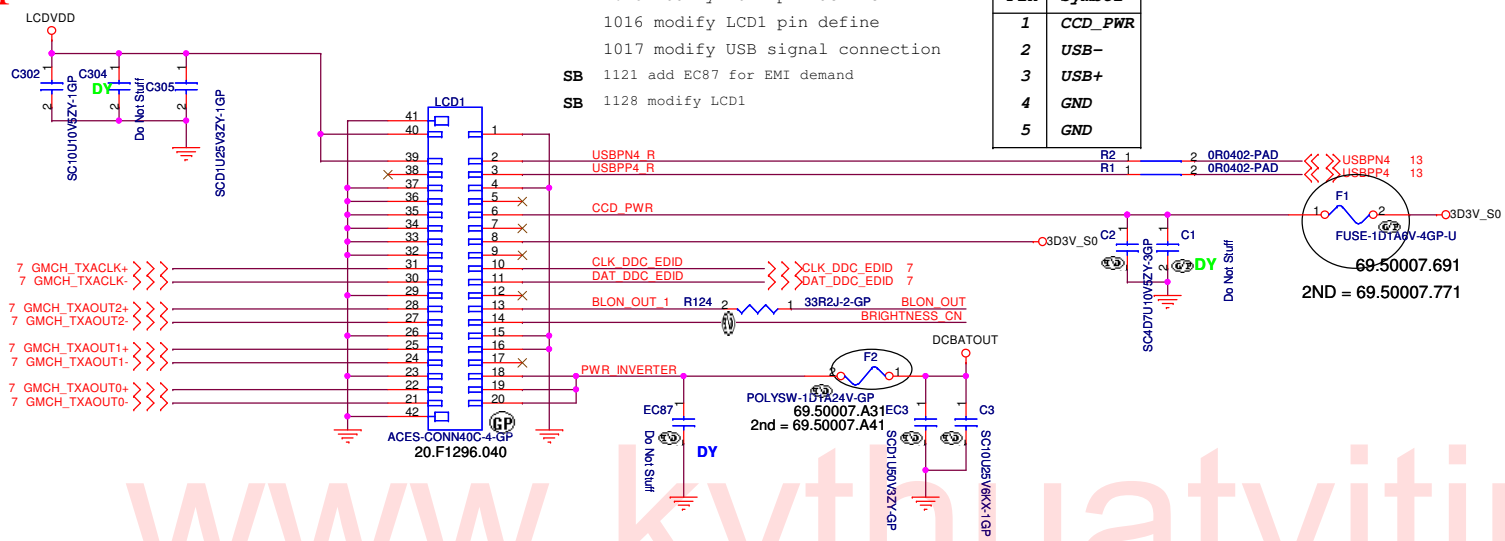

www.kythuatvith.com

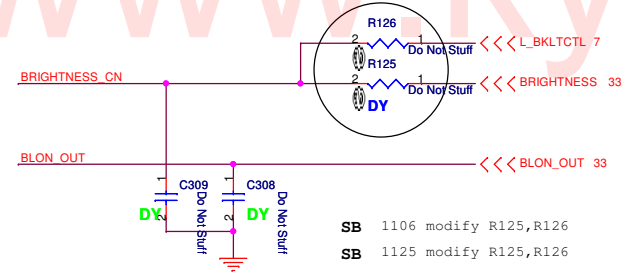

- SB 1106 modify R125,R126
- SB 1125 modify R125,R126

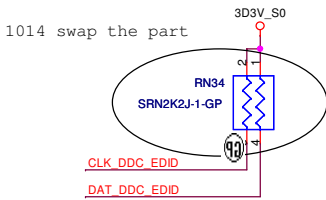

1014 swap the part

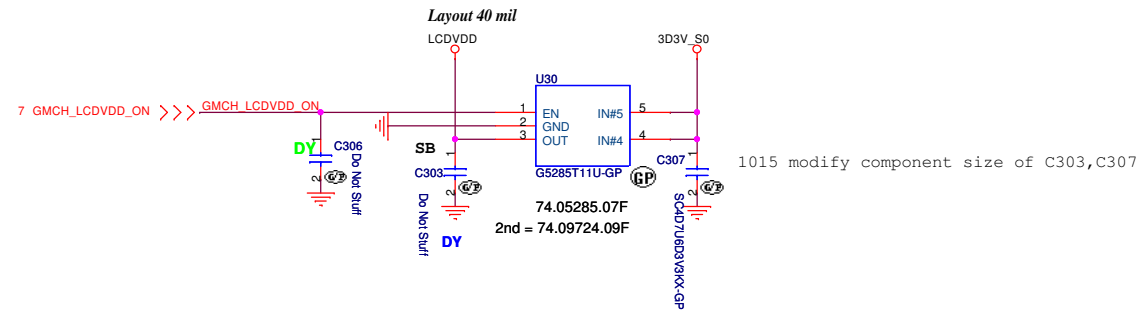

UMA Two Phase 2

		Wistron Corporation 21F, 88, Sec.1, Hsin Tai Wu Rd., Hsichih, Taipei Hsien 221, Taiwan, R.O.C.	
LCD CONN			
File	HM40-MV		
Size	Document Number	Rev	SB
Date:	Friday, November 28, 2008	Sheet	18 of 51

Layout Note:
Place these resistors close to the CRT-out connector

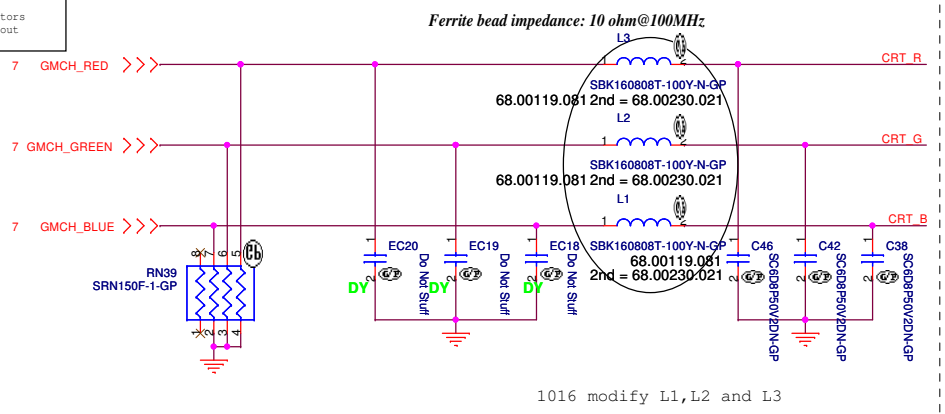

Layout Note:
* Must be a ground return path between this ground and the ground on the VGA connector.
Pi-filter & 150 Ohm pull-down resistors should be as close as to CRT CONN. RGB will hit 75 Ohm first, pi-filter, then CRT CONN.

Hsync & Vsync level shift

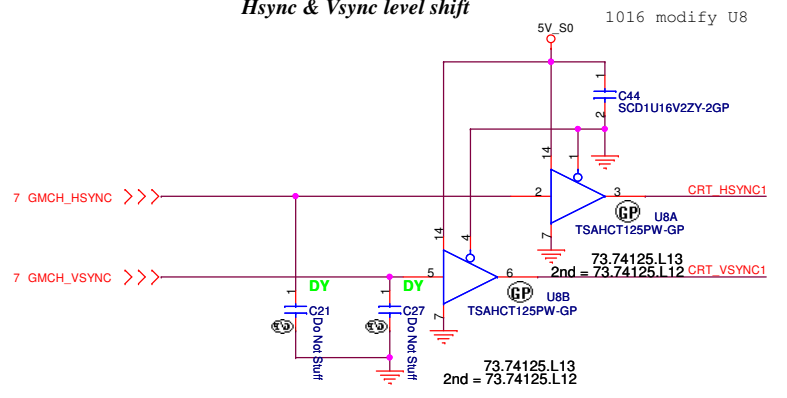

CRT I/F & CONNECTOR

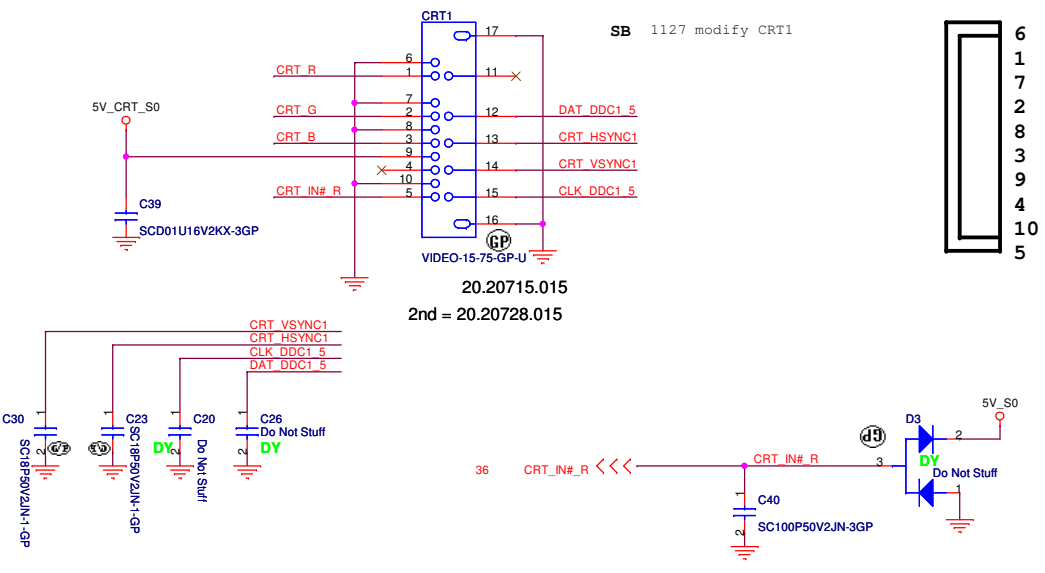

DDC_CLK & DATA level shift

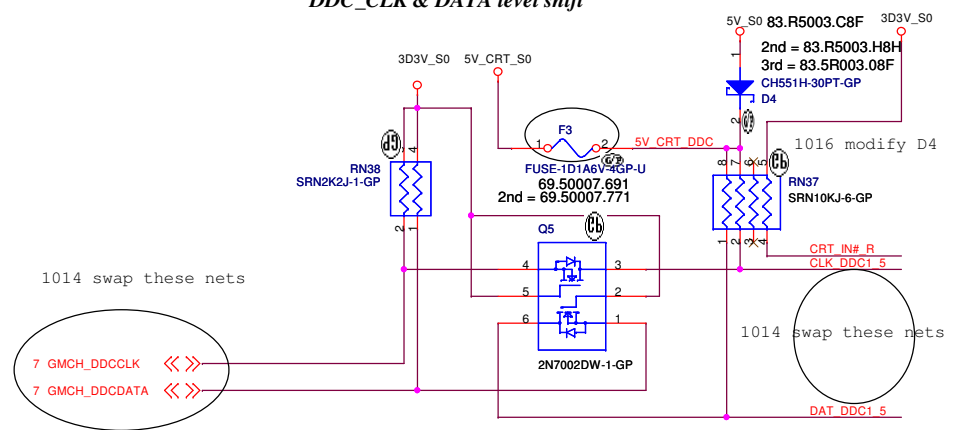

UMA Two Phase 2

緯創資通 Wistron Corporation
21F, 88, Sec. 1, Hsin Tai Wu Rd., Hsichih, Taipei Hsien 221, Taiwan, R.O.C.

Title: CRT Connector

Size: Document Number: HM40-MV Rev: SB

Date: Monday, December 01, 2008 Sheet 19 of 51

SATA Connector

0912 add these parts for EMI demand
1001 delete these parts for EMI demand
1021 modify SATA1

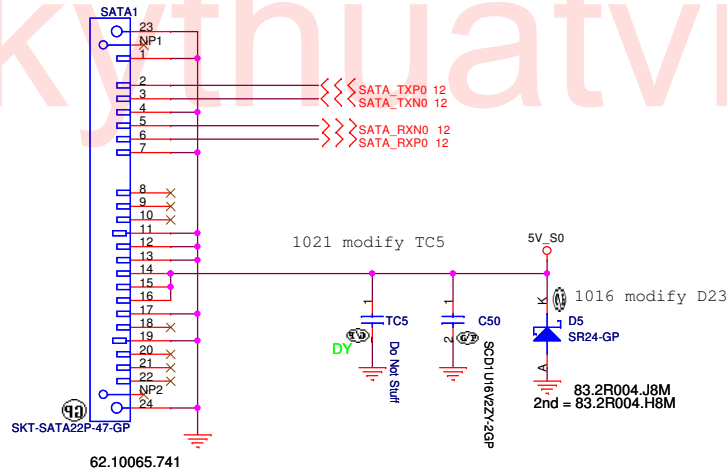

www.kyathuatvithinh.com

UMA Two Phase 2

Wistron Corporation 21F, 88, Sec. 1, Hsin Tai Wu Rd., Hsichih, Taipei Hsien 221, Taiwan, R.O.C.	
Title	
HDD	
Size	Document Number
	HM40-MV
Date: Monday, December 01, 2008	Sheet 20 of 51
Rev	SB

SATA ODD Connector

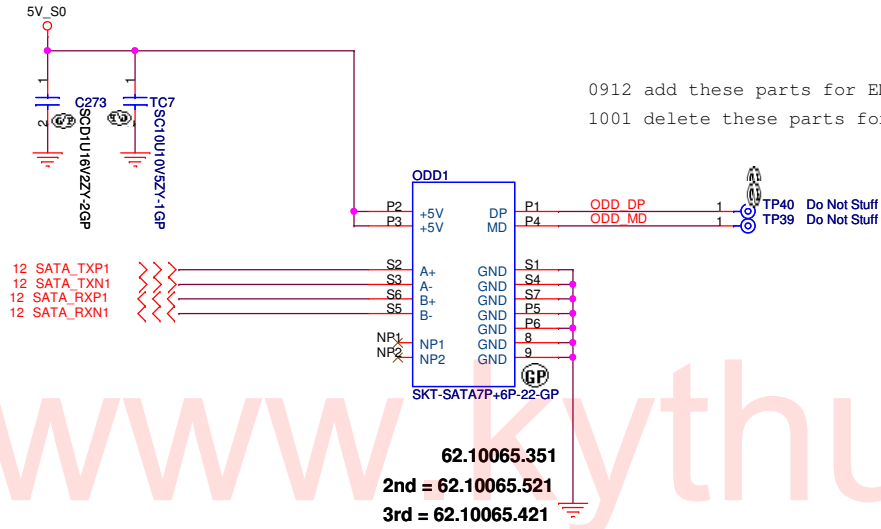

UMA Two Phase 2

緯創資通 **Wistron Corporation**
21F, 88, Sec.1, Hsin Tai WJ Rd., Hsichih,
Taipei Hsien 221, Taiwan, R.O.C.

Title			ODD
Size	Document Number	Rev	
	HM40-MV	SB	
Date:	Monday, December 01, 2008	Sheet	21 of 51

BLUETOOTH MODULE

1.5A / High Active Voltage 2V

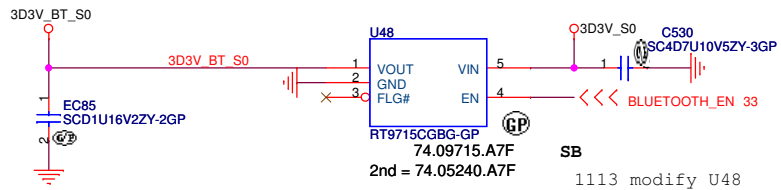

EC21 put near
BLUE1 / all
USB put one
choke near
connector by
EMI request

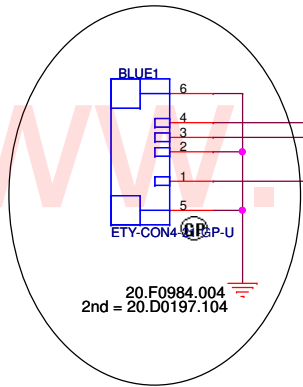

0930 modify BLUE1
1017 modify BLUE1

SB 1113 modify U48

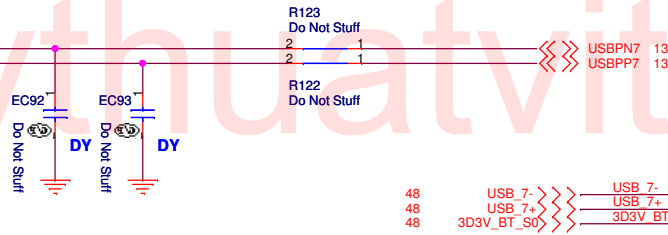

1017 modify USB signal connection

SB 1125 add EC92 and EC93

UMA Two Phase 2

		Wistron Corporation 21F, 88, Sec.1, Hsin Tai WJ Rd., Hsichih, Taipei Hsien 221, Taiwan, R.O.C.	
Title			
Bluetooth			
Size	Document Number		Rev
	HM40-MV		SB
Date:	Wednesday, November 26, 2008	Sheet 22 of	51

1017 modify USB signal connection
1021 modify and swap these parts(USB1 and USB2)

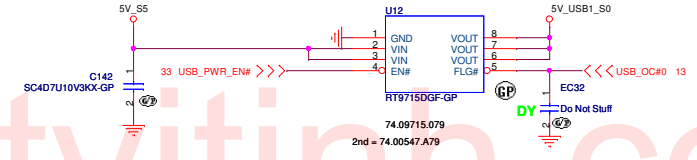
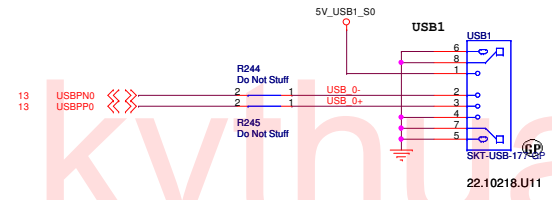
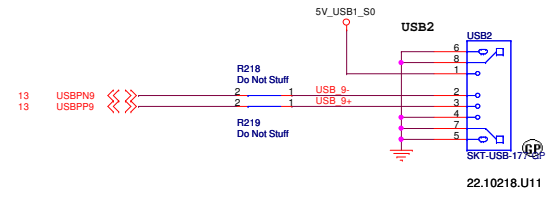

0912 add these parts for EMI demand

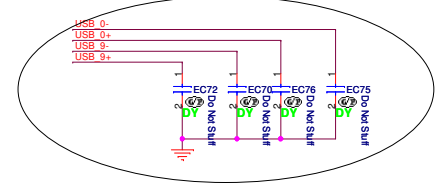

1021 delete TC23

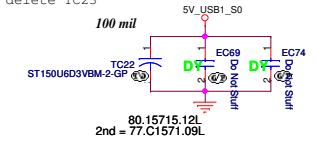

www.kytheatvitinn.com

UMA Two Phase 2

Wistron Corporation 21F, 88, Sec.1, Hsin Tai Wu Rd., Heichih, Taipei Hsien 221, Taiwan, R.O.C.	
File	
USB	
Size	Document Number
	HM40-MV
Date	Rev
Monday, December 01, 2008	SB
Sheet 23 of 51	

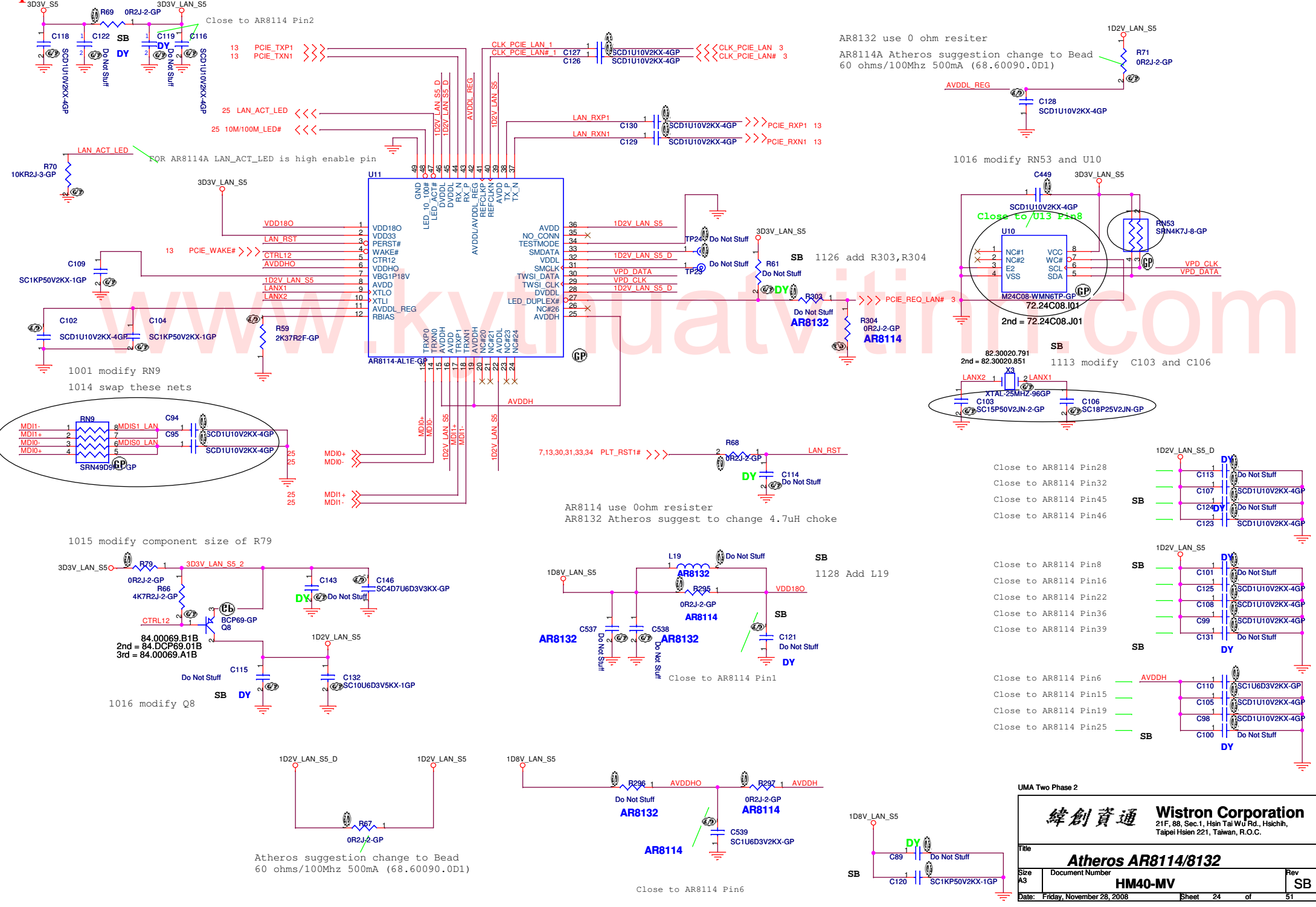

AR8132 use 0 ohm resister
 AR8114A Atheros suggestion change to Bead
 60 ohms/100Mhz 500mA (68.60090.0D1)

1016 modify RN53 and U10

1001 modify RN9
 1014 swap these nets

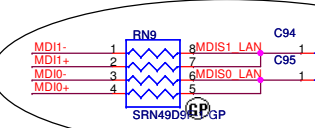

1015 modify component size of R79

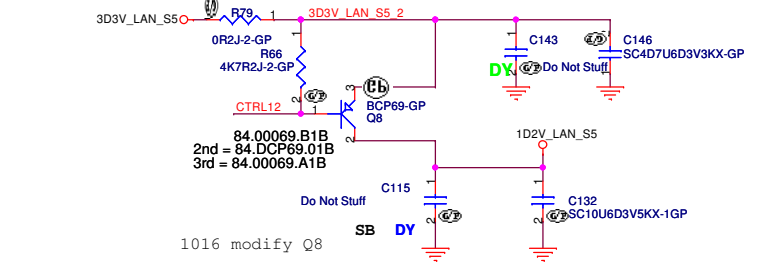

1016 modify Q8

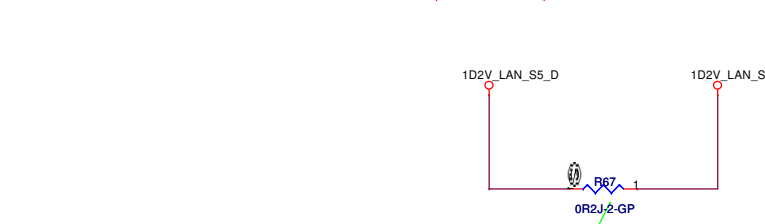

Atheros suggestion change to Bead
 60 ohms/100Mhz 500mA (68.60090.0D1)

AR8114 use 0ohm resister
 AR8132 Atheros suggest to change 4.7uH choke

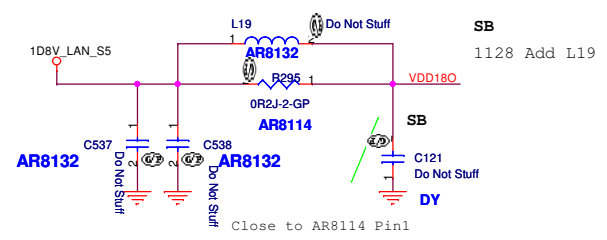

Close to AR8114 Pin6

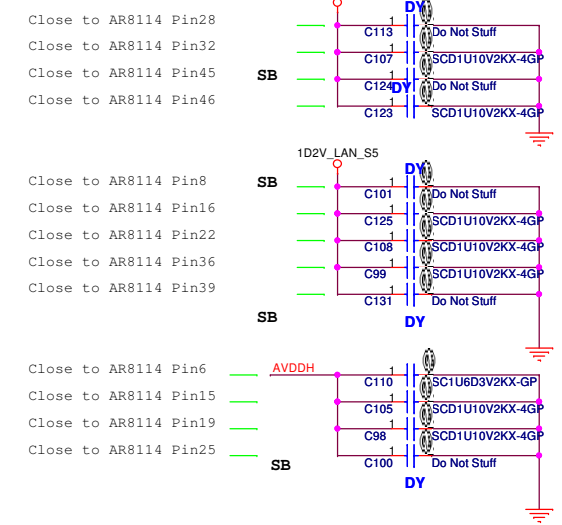

LAN Connector

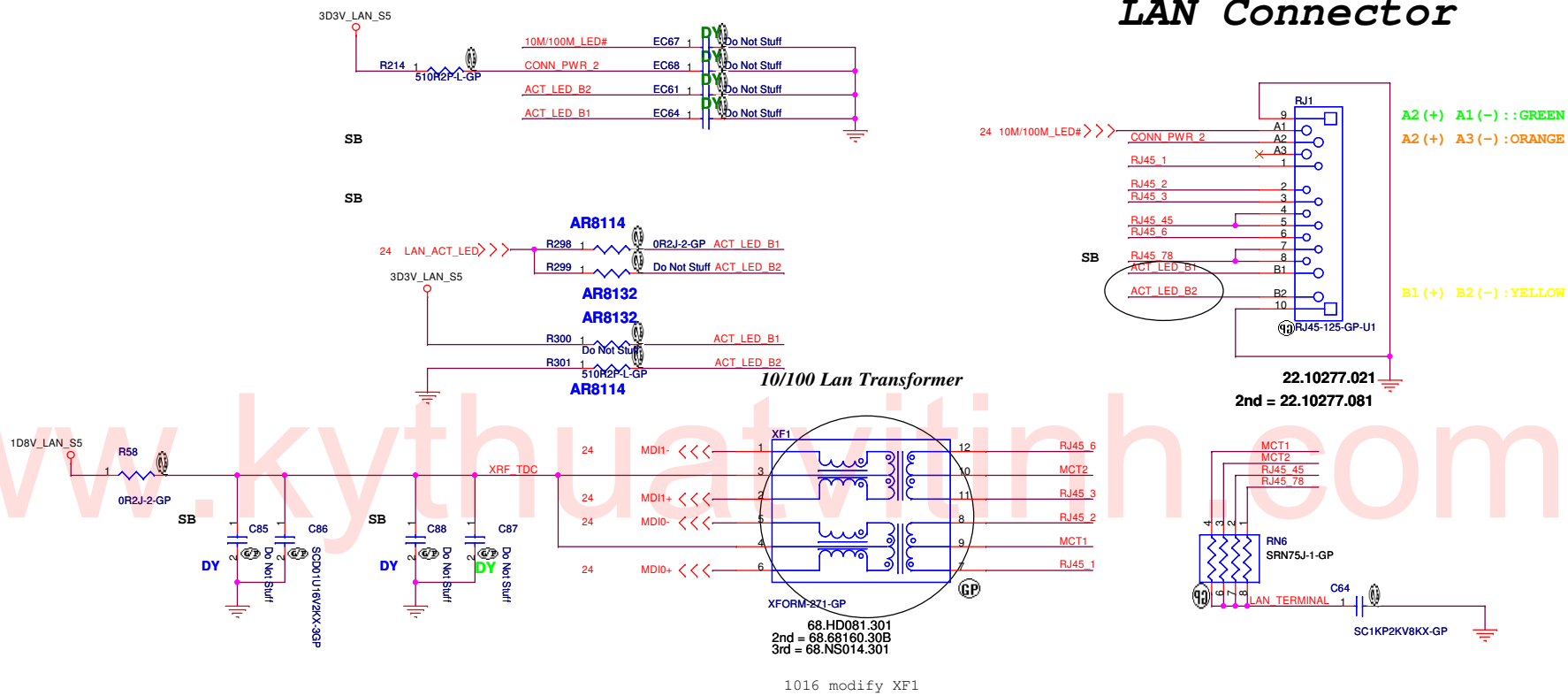

- 1. route on bottom as differential pairs.
- 2. Tx+/Tx- are pairs. Rx+/Rx- are pairs.
- 3. No vias, No 90 degree bends.
- 4. pairs must be equal lengths.
- 5. 6mil trace width, 12mil separation.
- 6. 36mil between pairs and any other trace.
- 7. Must not cross ground moat, except RJ-45 moat.

RJ11 signal must leave the other signal or power plane 100mil.

DOC_TIP, DOC_RING, TIP, RING:
 W/S : 10/100 @ Surface layers
 10/20 @ Inner layers

10/100 LAN Transformer	RJ45 PIN
TD+ --> TX+	RJ45-1
TD- --> TX-	RJ45-2
RD+ --> RX+	RJ45-3
RD- --> RX-	RJ45-6

UMA Two Phase 2

緯創資通 Wistron Corporation
 21F, 88, Sec. 1, Hsin Tai Wu Rd., Hsichih, Taipei Hsien 221, Taiwan, R.O.C.

Title: **LAN Connector**

Size A3 Document Number **HM40-MV** Rev **SB**

Date: Monday, December 01, 2008 Sheet 25 of 51

SB 1118 delete C245 and C270

0911 add net name(DVDD_1_8)

0911 add net name(ACZ_SDATAIN0_R)

12 ACZ_RST#_AUDIO >>>
 12 ACZ_BITCLK_AUDIO >>>
 12 ACZ_SYNC_AUDIO >>>
 12 ACZ_SDATAIN0 >>>
 12 ACZ_SDATAOUT_AUDIO >>>

SB 1126 add C541 and modify R101

27 EAPD# <<<

0912 add the part for EMI demand

PC BEEP GAIN CONTROL

Default gain is -6dB without populating the 10K-ohms pull-down resistors going to GPIO1 and GPIO2.

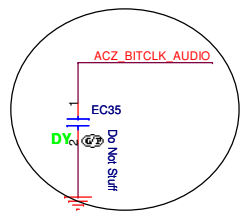
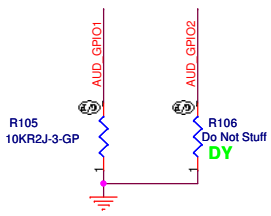

GAIN	10K GPIO RESISTORS	
	R615	R614
0dB	Populate	Populate
-6dB	Omit	Omit
-12dB	Populate	Omit
-18dB	Omit	Populate

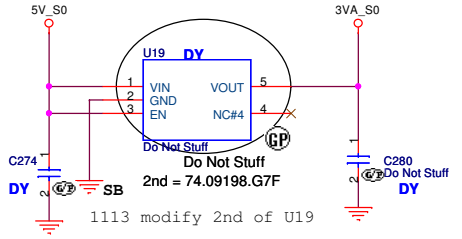
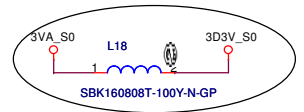
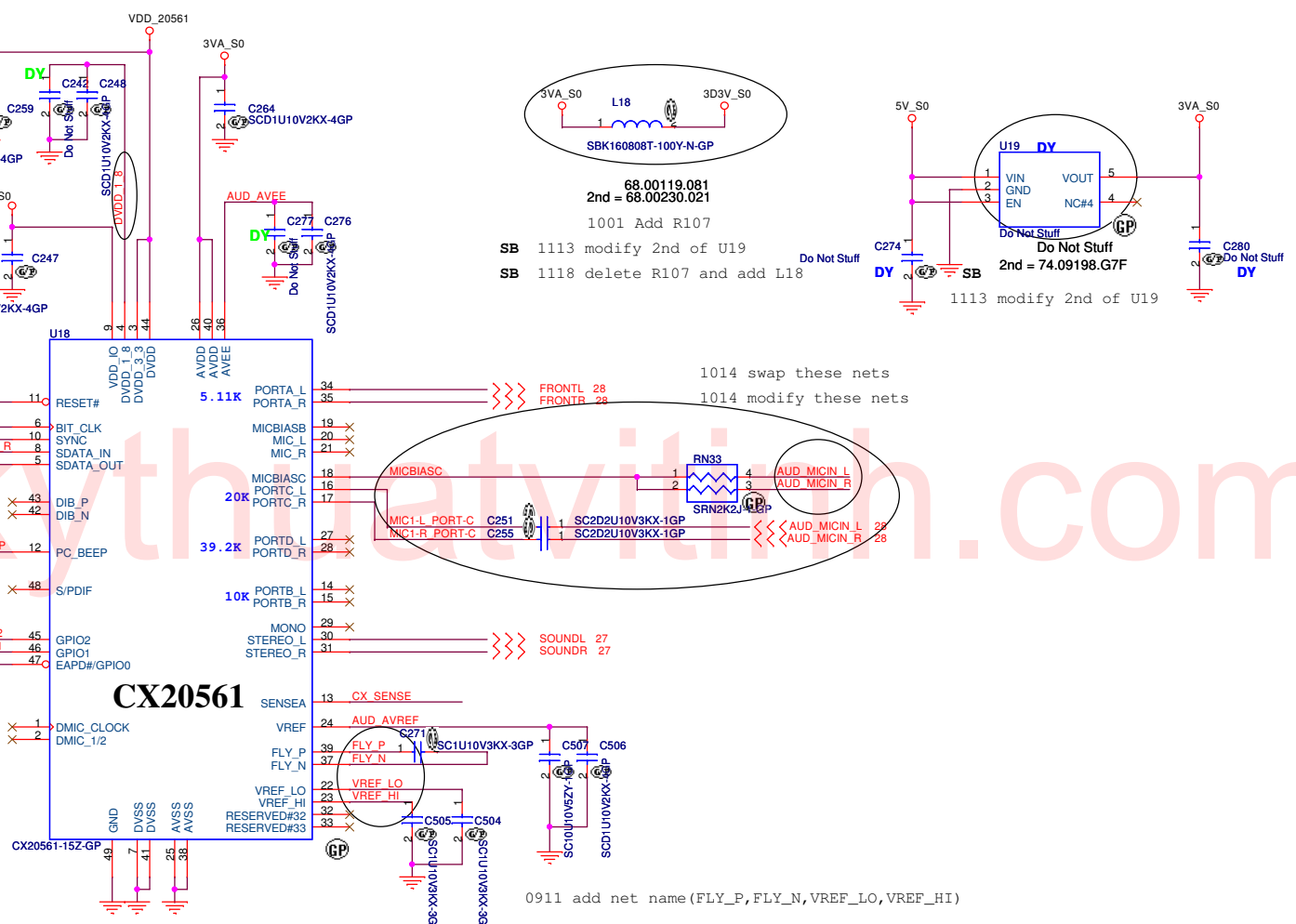

68.00119.081
 2nd = 68.00230.021

1001 Add R107

SB 1113 modify 2nd of U19

SB 1118 delete R107 and add L18

Do Not Stuff

DY

Do Not Stuff

SB

1113 modify 2nd of U19

1014 swap these nets
 1014 modify these nets

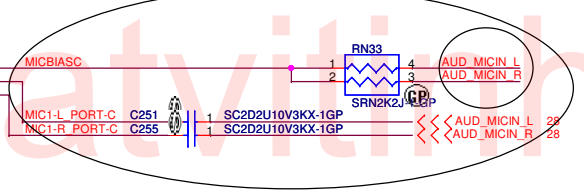

AUDIO OP AMPLIFIER

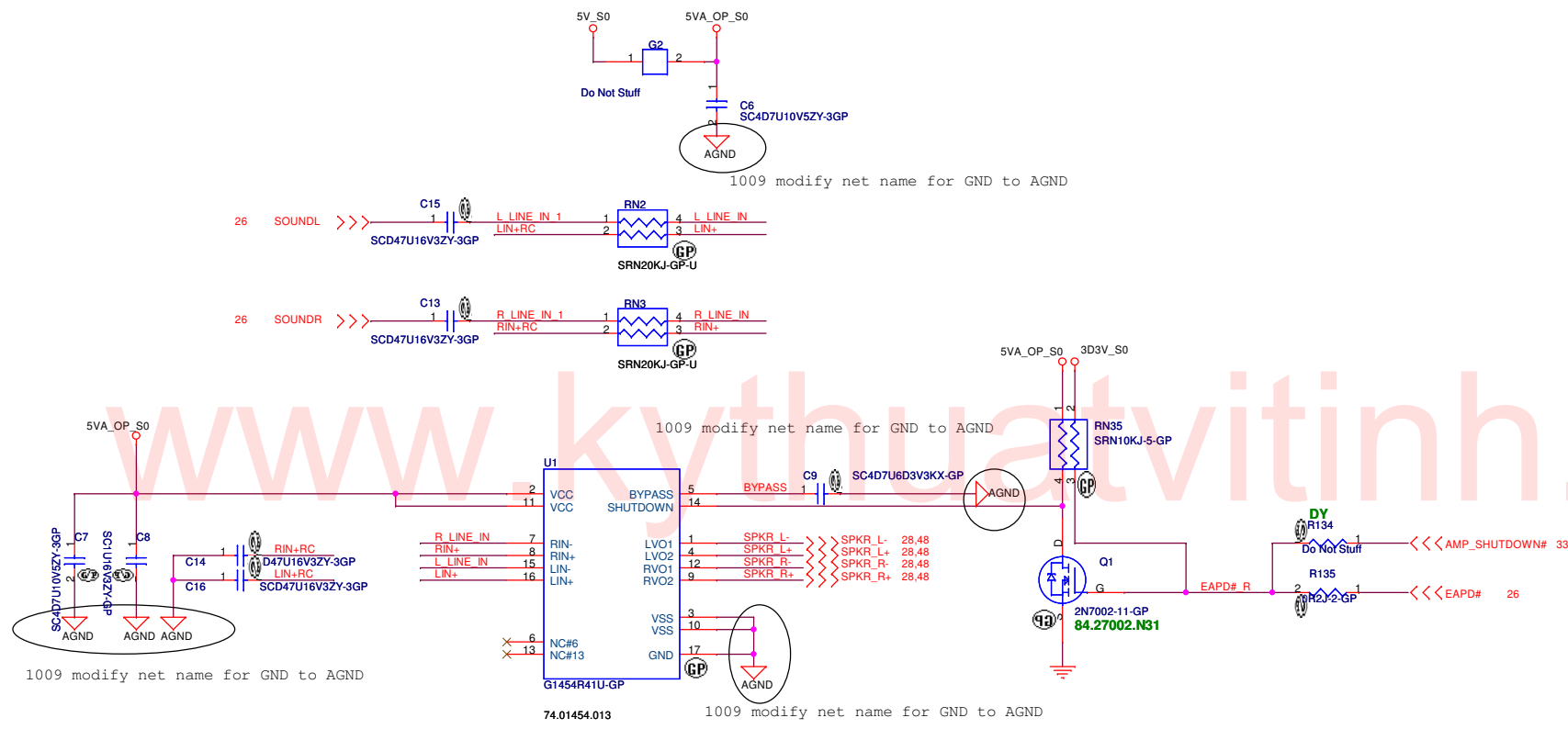

1009 modify net name for GND to AGND

1009 modify net name for GND to AGND

1009 modify net name for GND to AGND

1009 modify net name for GND to AGND

1014 swap these nets

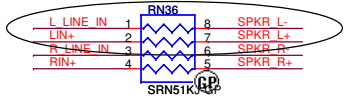
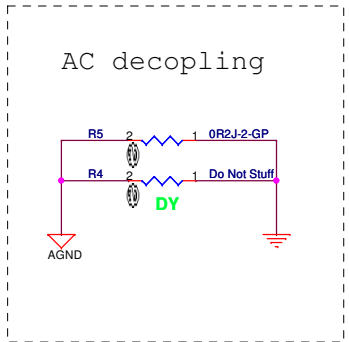

MIC IN

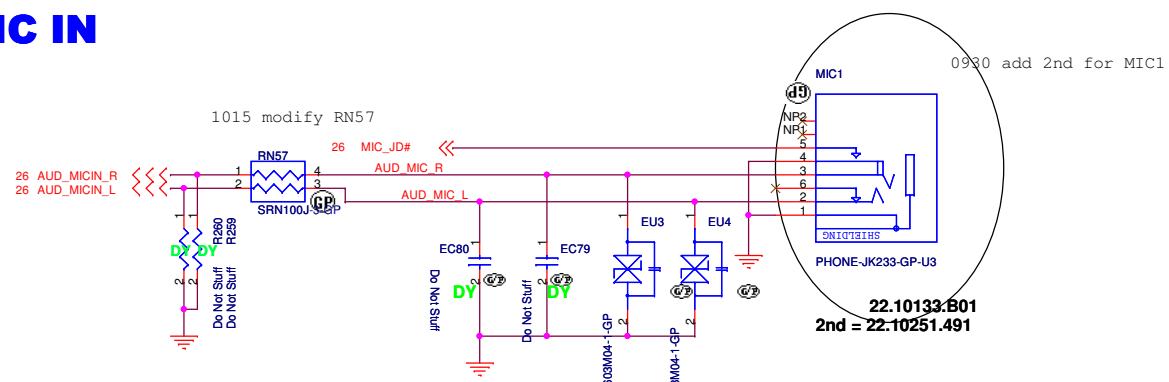

LINE OUT

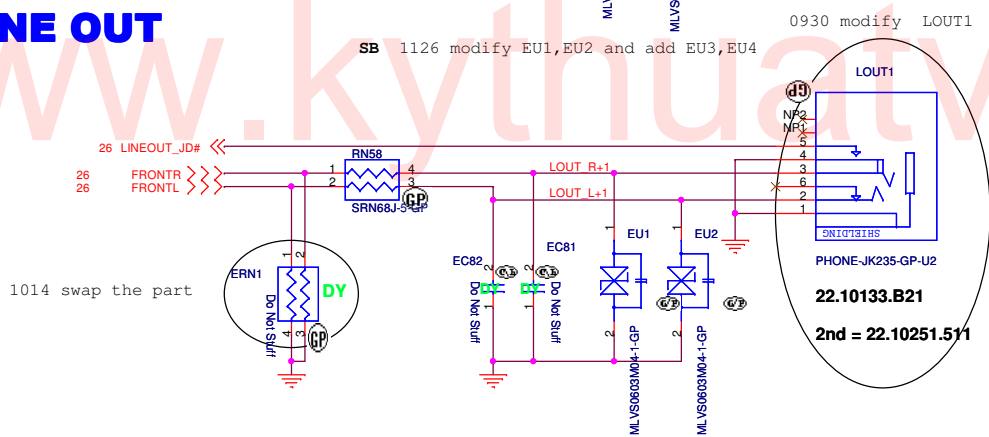

Internal Speaker

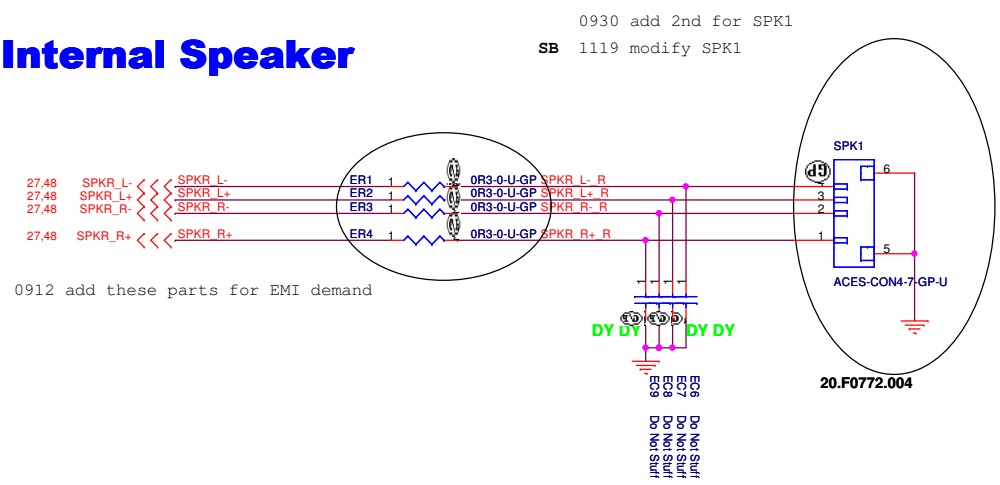

UMA Two Phase 2

緯創資通 Wistron Corporation
21F, 88, Sec.1, Hsin Tai Wu Rd., Hsichih,
Taipei Hsien 221, Taiwan, R.O.C.

Title: **AUDIO JACK**

Size: Document Number **HM40-MV** Rev: **SB**

Date: Monday, December 01, 2008 Sheet 28 of 51

MDC 1.5 CONN

0912 add the part for EMI demand

1002 modify MDC1

SB

1112 delete MDC function

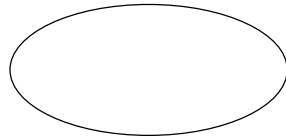

www.kythuatvith.com

UMA Two Phase 2

緯創資通 **Wistron Corporation**
21F, 88, Sec.1, Hsin Tai WJ Rd., Hsichih,
Taipei Hsien 221, Taiwan, R.O.C.

Title			MDC		
Size	Document Number	HM40-MV		Rev	SB
Date:	Monday, November 24, 2008	Sheet	29	of	51

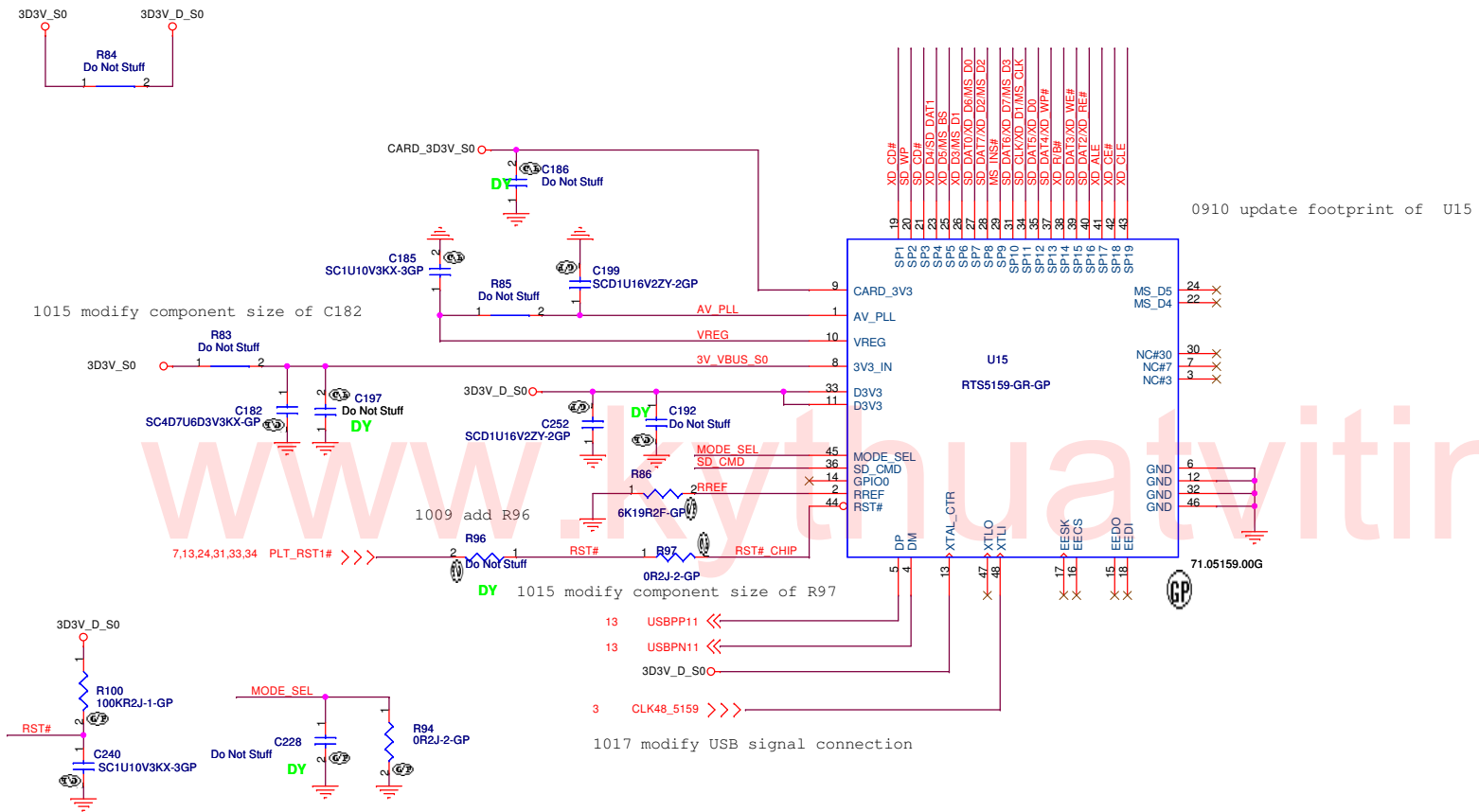

5 IN 1 CARD-READER (SD/MMC/MS/MS PRO/XD)

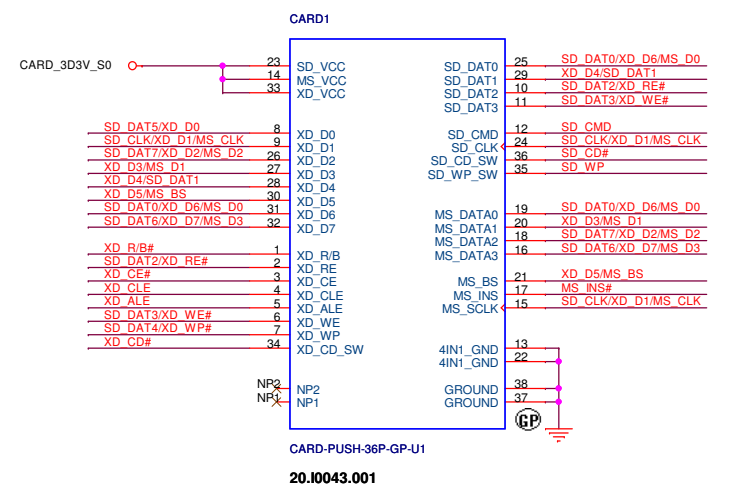

1009 modify this net
1013 modify card1

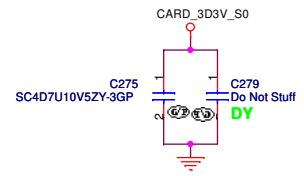
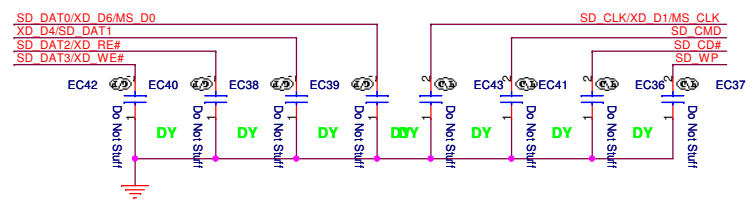

UMA Two Phase 2

緯創資通 Wistron Corporation
21F, 88, Sec.1, Hsin Tai Wu Rd., Hsichih, Taipei Hsien 221, Taiwan, R.O.C.

Title: **CARD READER- RTS5159**

Size	Document Number	Rev
	HM40-MV	SB

Date: Monday, December 01, 2008 Sheet 30 of 51

Mini Card Connector(WLAN)

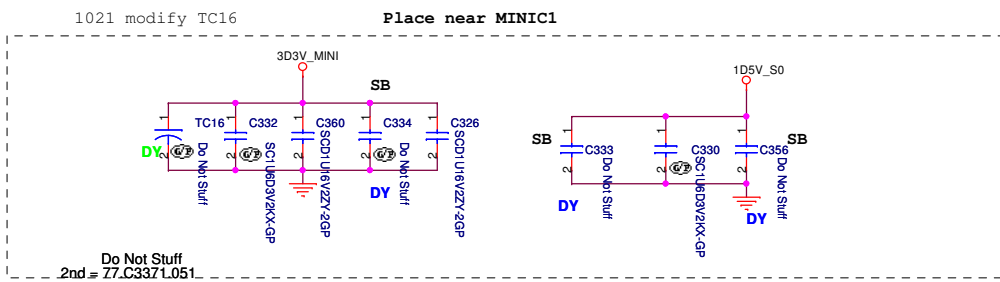
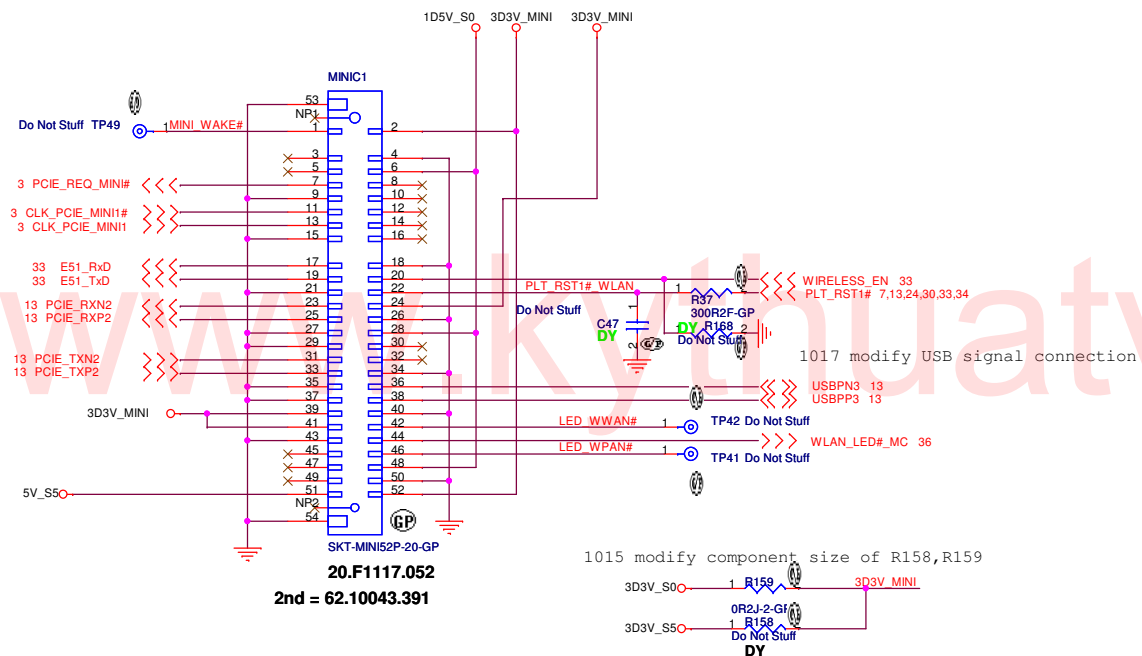

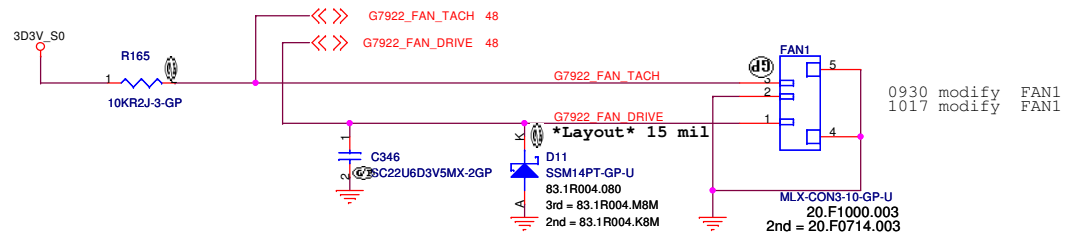

Layout notice :
Both H_THERMDA and THERMDC routing
10 mil trace width and 10 mil spacing

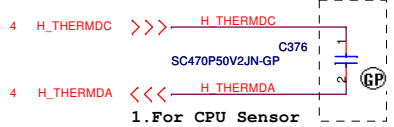

C374 must be near Q7
C373 must be near EMC2102
Layout notice : Both SGND2 and DXP2 routing
10 mil trace width and 10 mil spacing

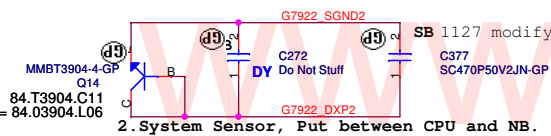

Layout notice : Both SGND3 and DXP3 routing
10 mil trace width and 10 mil spacing

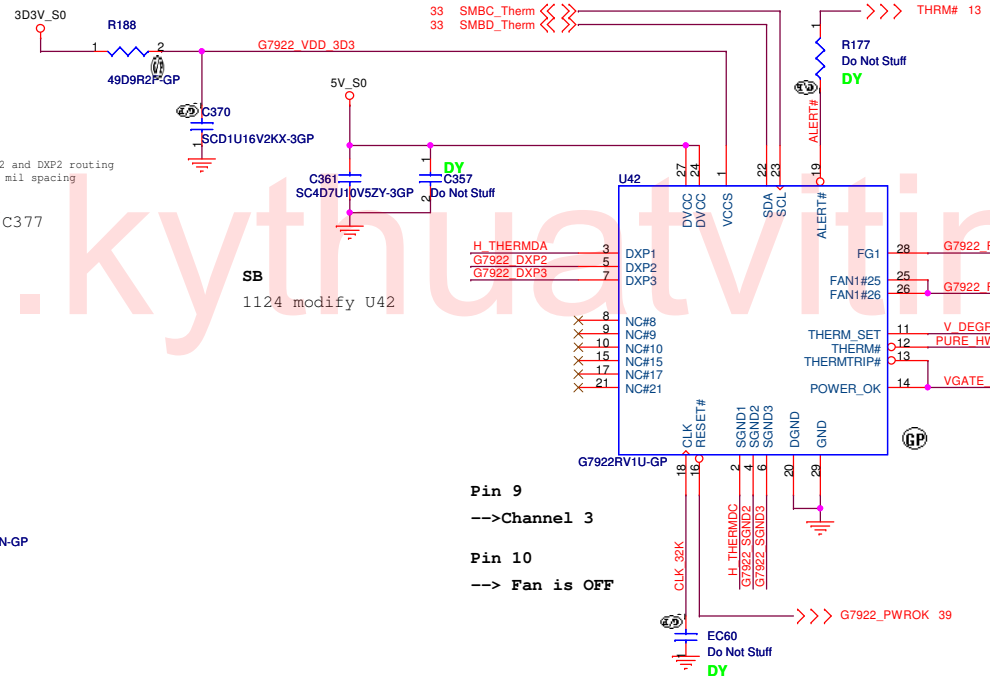
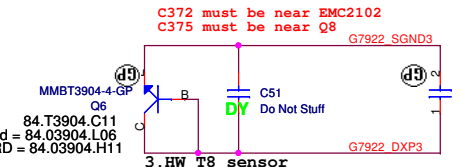

Pin 9
--> Channel 3
Pin 10
--> Fan is OFF

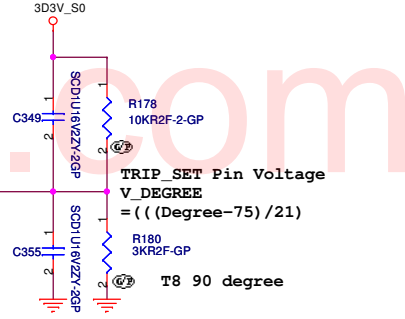

$$\text{TRIP_SET Pin Voltage} \\ V_DEGREE \\ = ((\text{Degree} - 75) / 21)$$

$$\text{THERM_SET} \\ = (\text{Test} - 75) * (1/32) * (15/33) \text{VCCS}$$

SB 1125 modify RN40 and delete RN42

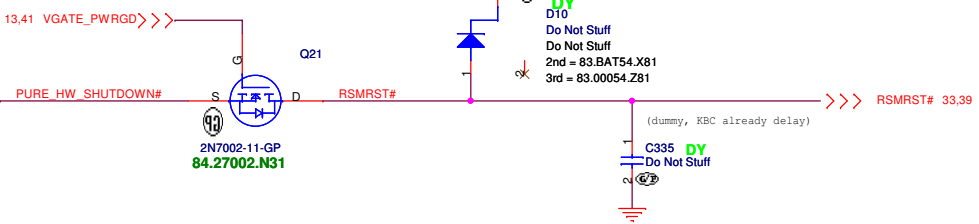
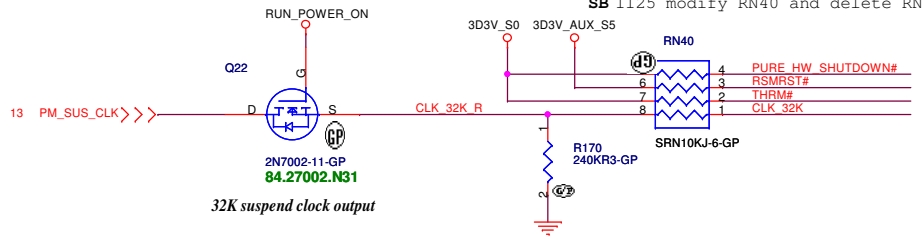

UMA Two Phase 2

<p>緯創資通 Wistron Corporation 21F, 88, Sec.1, Hsin Tai Wu Rd., Hsichih, Taipei Hsien 221, Taiwan, R.O.C.</p>	
<p>File Thermal/Fan Controller</p>	
Size	Document Number
	HM40-MV
Date: Monday, December 01, 2008	Sheet 32 of 51

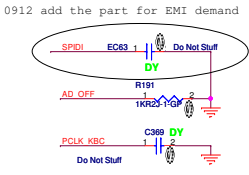
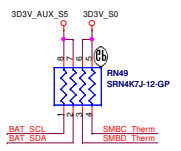
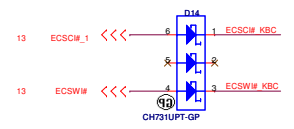
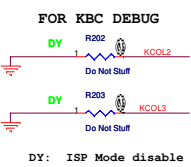
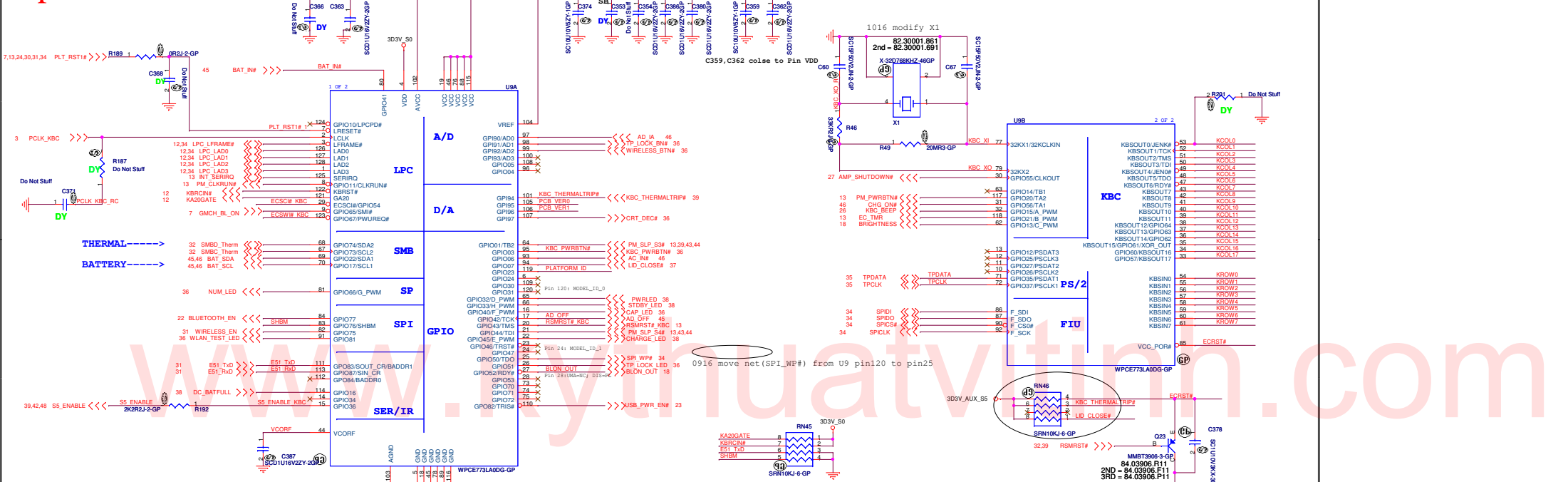

0930 modify net name for BIOS demand

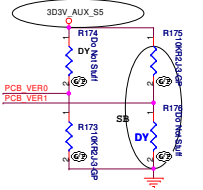

PlanarID (0,1)
SA: 0,0
SB: 0,1
SC: 1,0
SD: 1,1

1118 modify PCB Ver. from SA to SB

Internal KeyBoard Connector

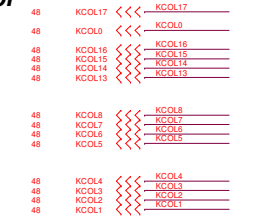
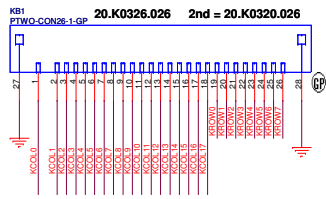

0930 modify KB1

Internal KeyBoard CONN

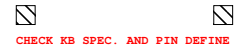
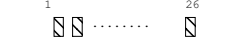

CHECK KB SPEC. AND PIN DEFINE

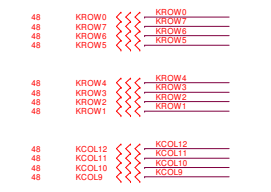

UMA 2 Phase 2

緯創資通 Wistron Corporation
21F, 88, Sec.1, Hsin Tai Wu Rd., Hsichih, Taipei Hsien 221, Taiwan, R.O.C.

File: **KBC WPCE773L**

Size: Document Number **HM40-MV** Rev: **SB**

Date: Wednesday, November 28, 2008 Sheet 33 of 51

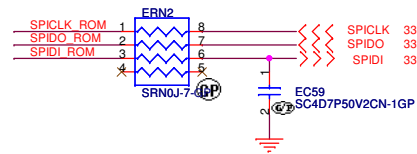
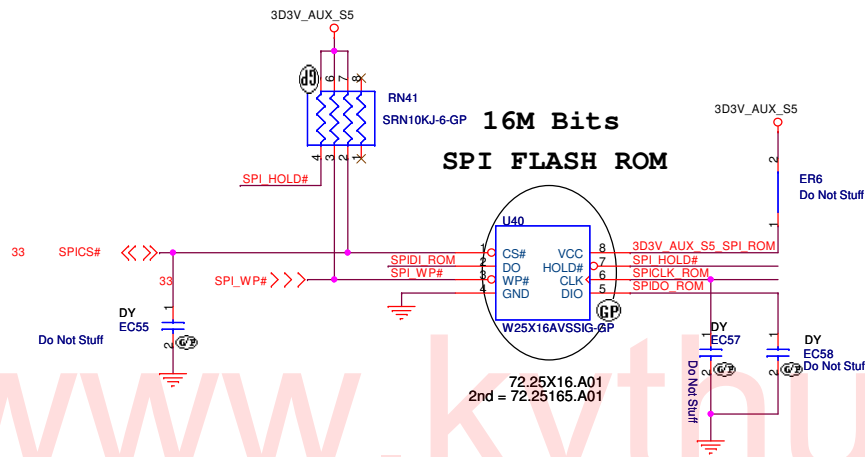

GOLDEN FINGER FOR DEBUG BOARD

1013 modify U40 from 72.25X16.001 to 72.25X16.A01
 0912 add the part for EMI demand

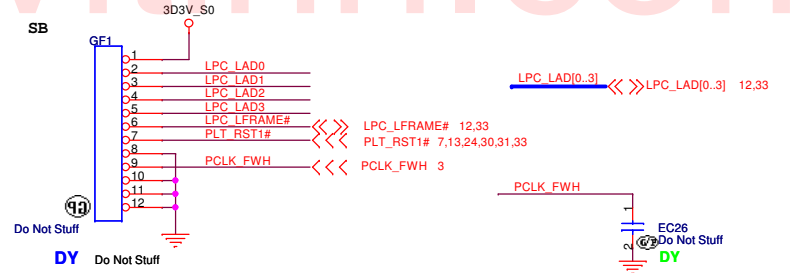
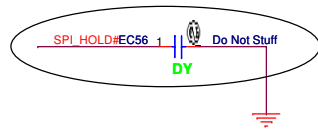

UMA Two Phase 2

TOUCH PAD

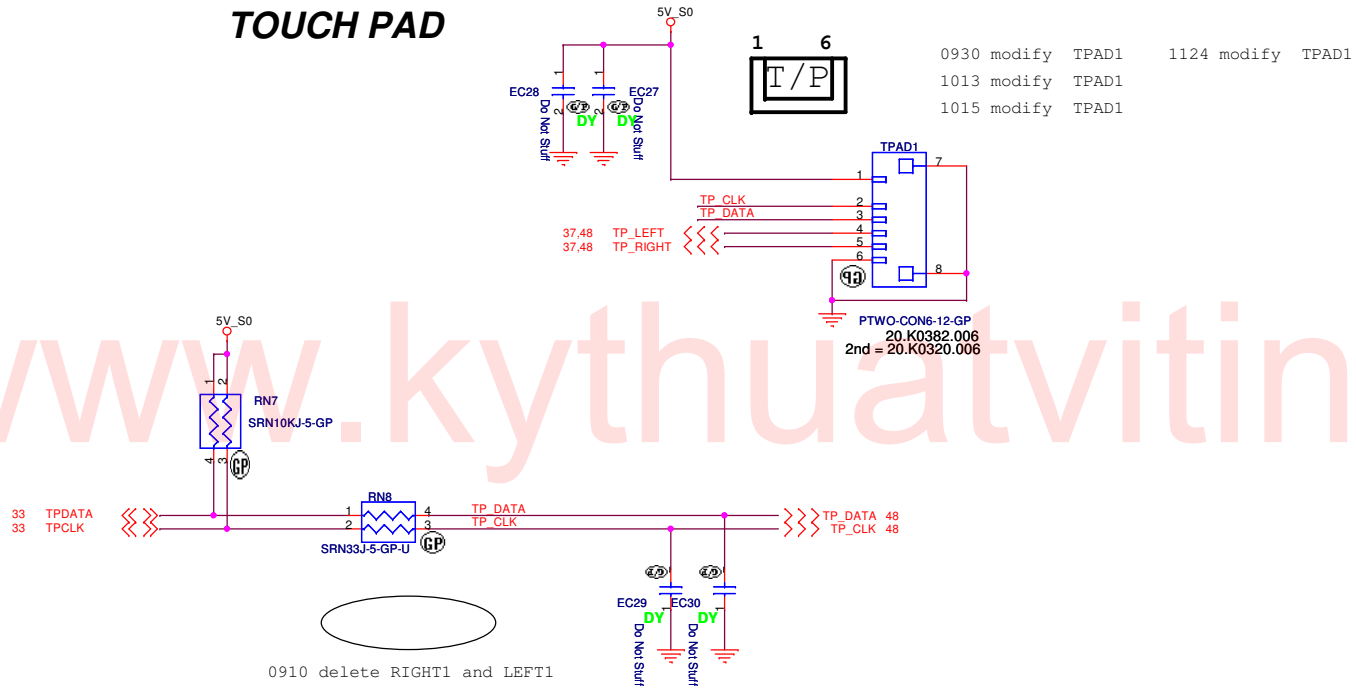

www.kythuathvithinh.com

UMA Two Phase 2

緯創資通 Wistron Corporation		
21F, 88, Sec.1, Hsin Tai Wu Rd., Hsichih, Taipei Hsien 221, Taiwan, R.O.C.		
Title Touch pad		
Size	Document Number HM40-MV	Rev SB
Date: Monday, December 01, 2008	Sheet 35 of	51

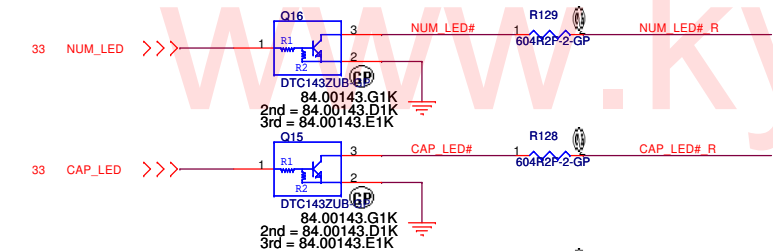
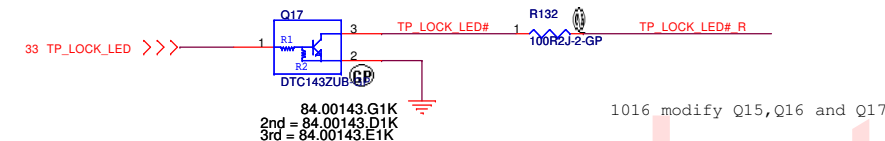
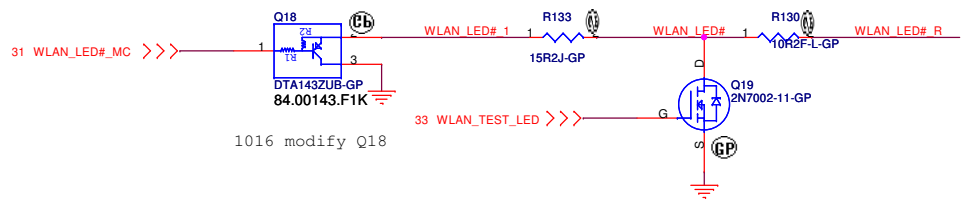

SB
1112 remove these signals(STDBY_LED#_FR and STDBY_LED#_R) and R131

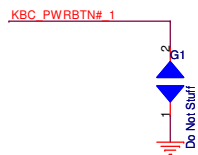
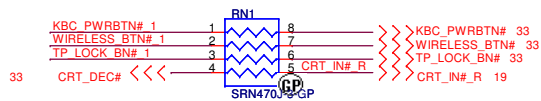

0912 add these parts for EMI demand

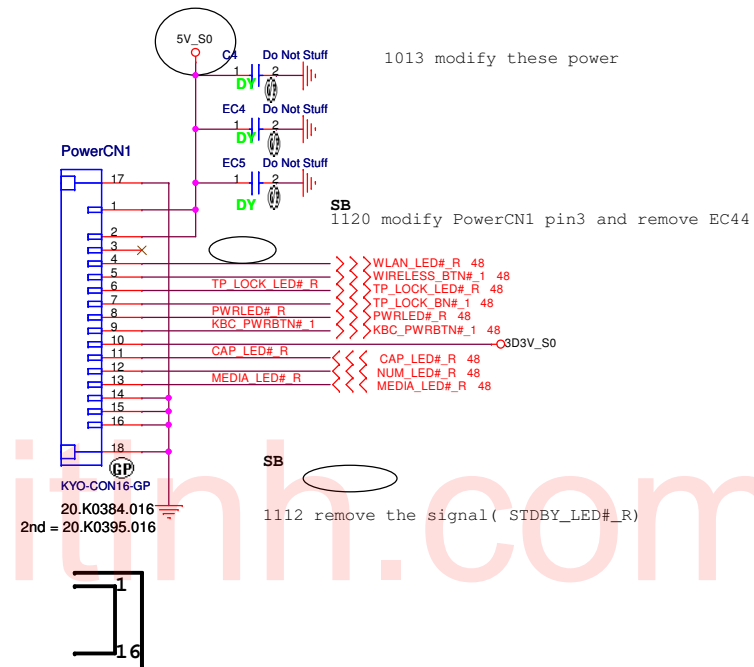
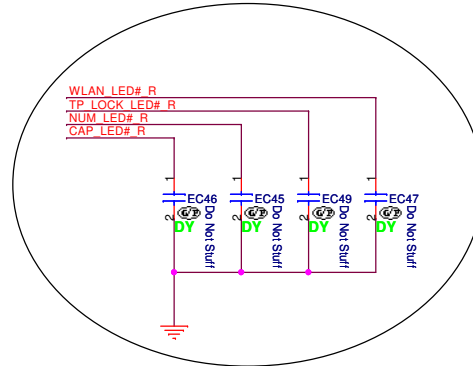

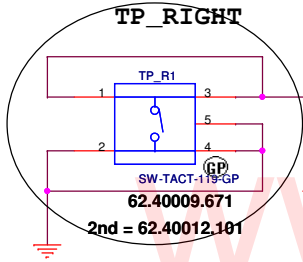
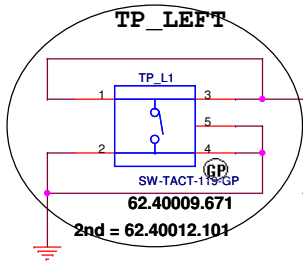

1017 modify RN60

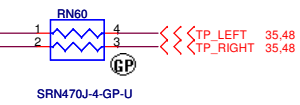

Cover Up Switch

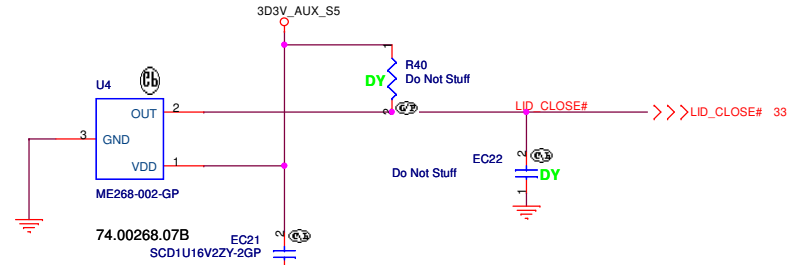

1016 modify U4
1017 modify U4

1017 add U61,R52,EC24 and EC23
1020 delete U61,R52,EC24 and EC23

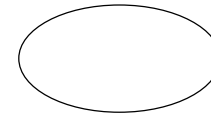

UMA Two Phase 2

Wistron Corporation 21F, 88, Sec.1, Hsin Tai Wu Rd., Hsichih, Taipei Hsien 221, Taiwan, R.O.C.	
Title	
SWITCHS	
Size	Document Number
HM40-MV	
Date: Monday, December 01, 2008	Sheet 37 of 51
Rev SB	

1015 modify the power from 3D3V_S5 to 5V_S5

SB 1106 modify LED11

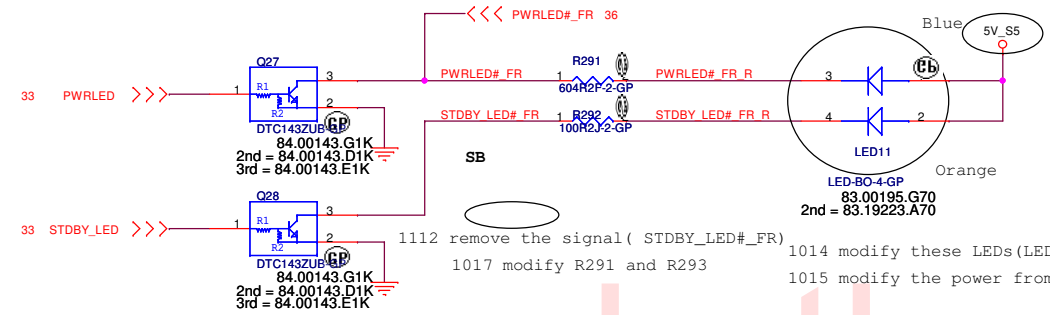

1112 remove the signal(STDBY_LED#_FR)
1017 modify R291 and R293

1014 modify these LEDs(LED11,LED12)
1015 modify the power from 3D3V_S5 to 5V_S5

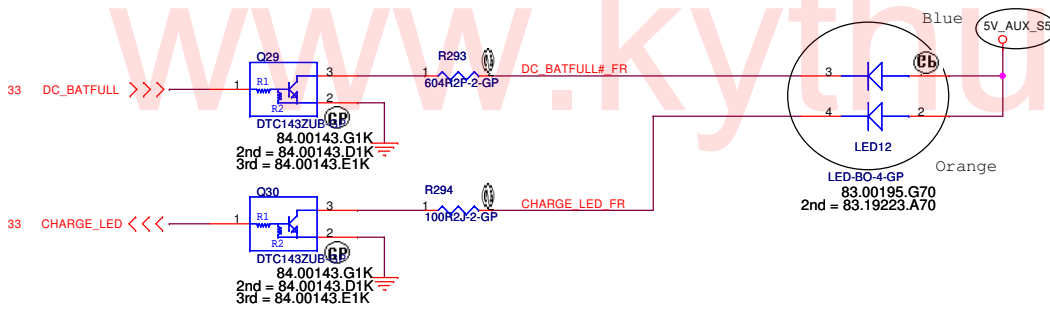

SB 1106 modify LED12
1106 modify LED power from 5V_S5 to 5V_AUX_S5

1016 modify Q27~Q30

UMA Two Phase 2

		Wistron Corporation 21F, 88, Sec.1, Hsin Tai Wu Rd., Hsichih, Taipei Hsien 221, Taiwan, R.O.C.
Title		
LED		
Size	Document Number	Rev
	HM40-MV	SB
Date: Wednesday, November 26, 2008		
Sheet 38		of 51

Run Power

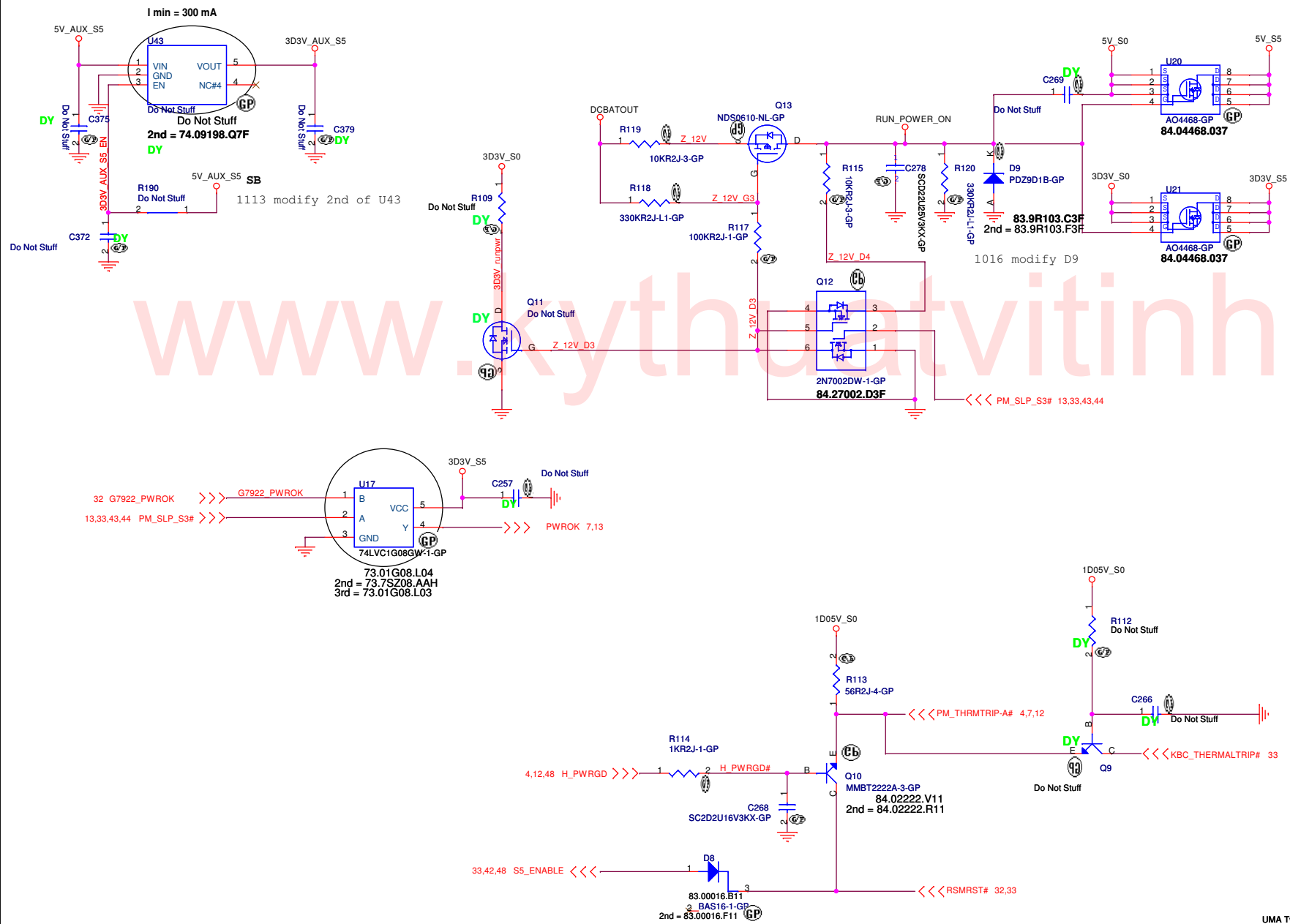

CPU_CORE
ISL6266A

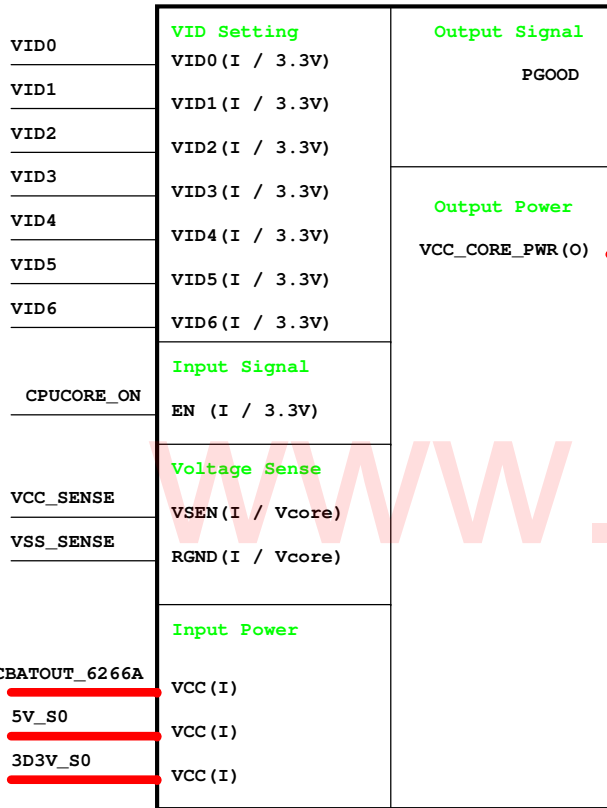

TPS51125
5V/3D3V

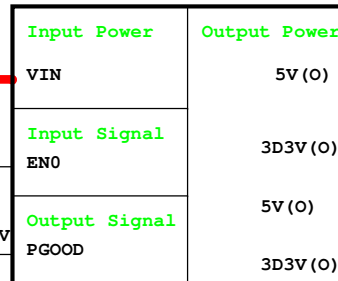

RT9018A
1D5V_S0

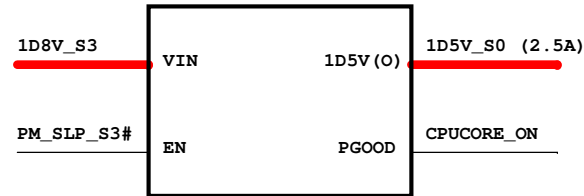

RT9026 **0D9V_S0**

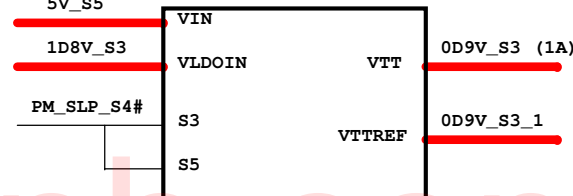

www.kythuatvithinh.com

TPS51124
1D8V/1D05V

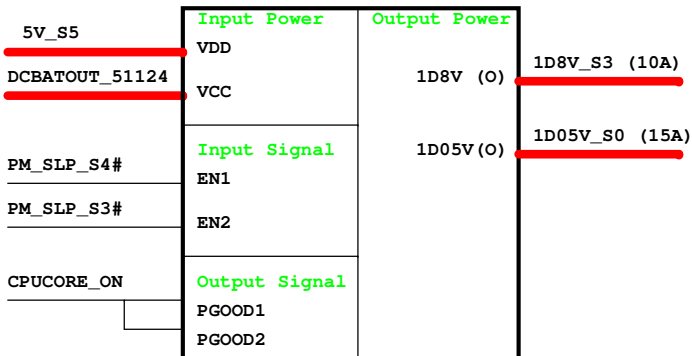

Adapter

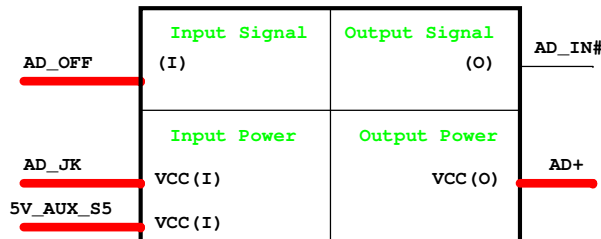

Charger BQ24745

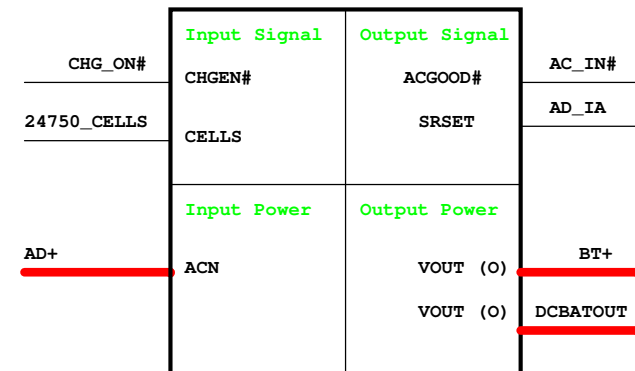

UMA Two Phase 2

緯創資通 **Wistron Corporation**
21F, 88, Sec.1, Hsin Tai WJ Rd., Hsichih,
Taipei Hsien 221, Taiwan, R.O.C.

Title			Power Sequence Logic	
Size B	Document Number	HM40-MV		Rev
				SB
Date:	Monday, November 24, 2008	Sheet	40	of
			51	

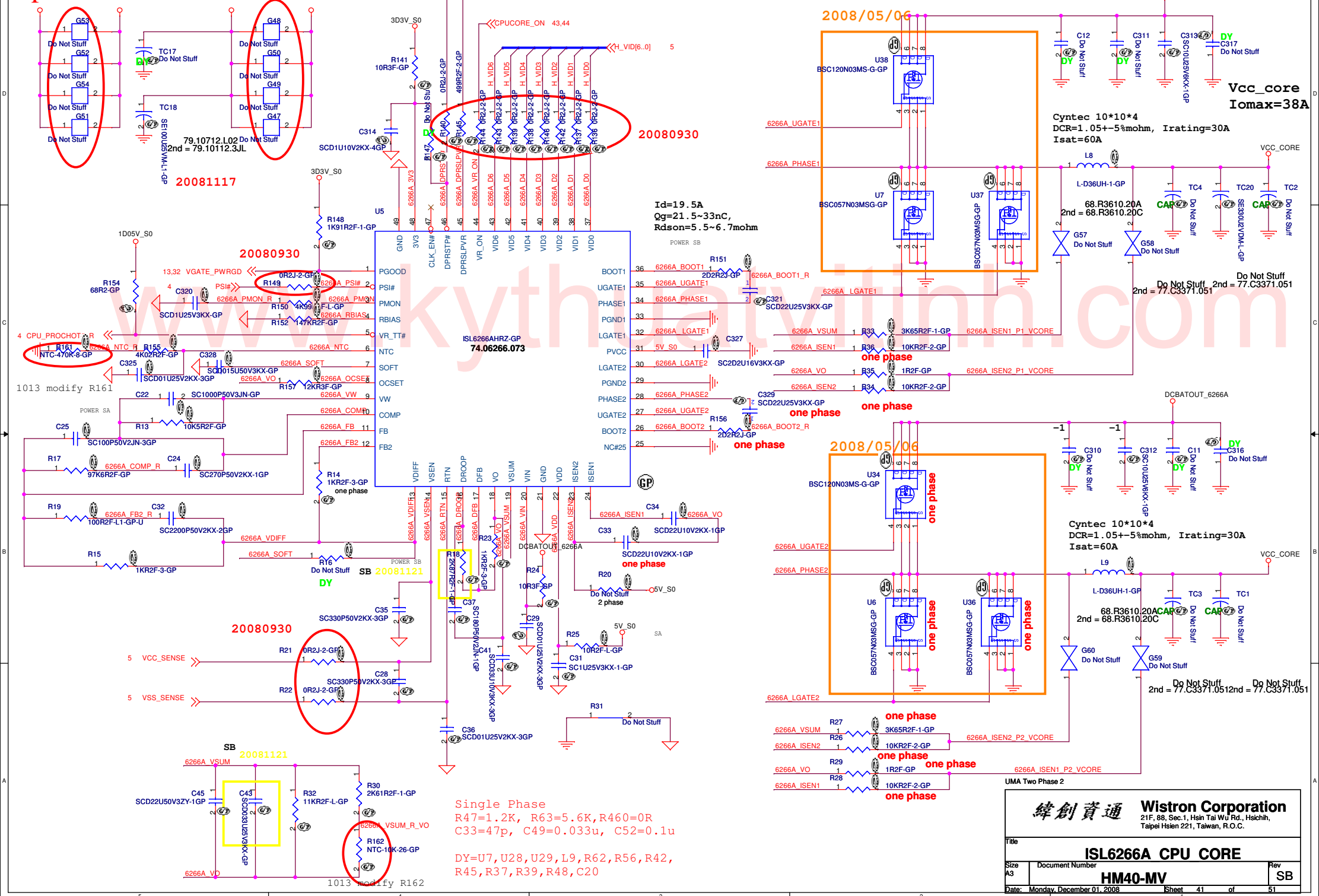

Single Phase
 R47=1.2K, R63=5.6K, R460=0R
 C33=47p, C49=0.033u, C52=0.1u
 DY=U7, U28, U29, L9, R62, R56, R42,
 R45, R37, R39, R48, C20

緯創資通		Wistron Corporation	
21F, 88, Sec. 1, Hsin Tai Wu Rd., Hsichih, Taipei Hsien 221, Taiwan, R.O.C.			
ISL6266A CPU CORE			
Title	Document Number	Rev	SB
HM40-MV			
Date: Monday, December 01, 2008	Sheet 41	of	51

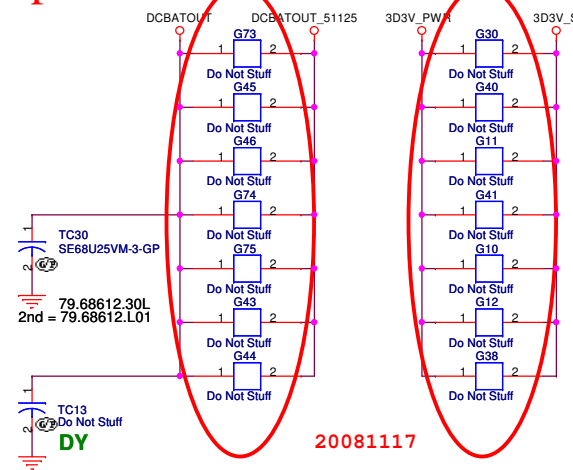

20081117

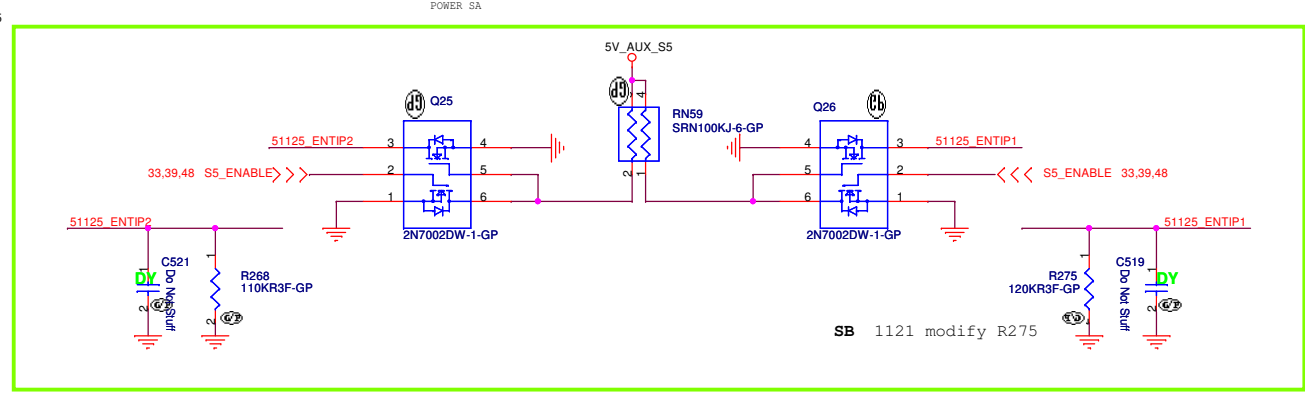

SB 1121 modify R275

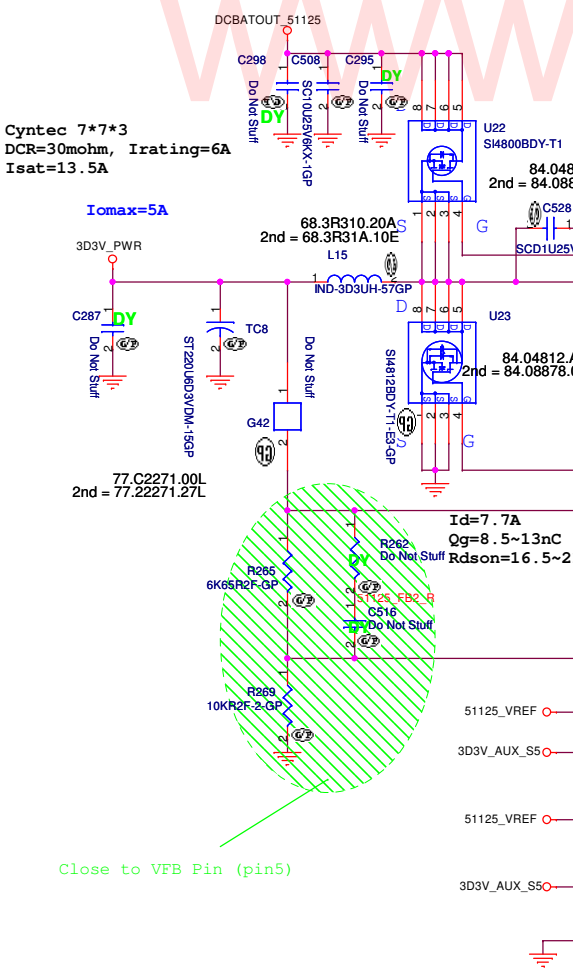
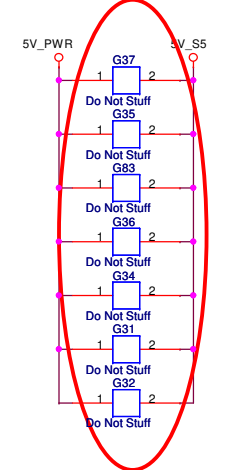

Cyntec 7*7*3
DCR=30mohm, Irating=6A
Isat=13.5A

Iomax=5A

77.2271.00L
2nd = 77.2271.27L

Close to VFB Pin (pin5)

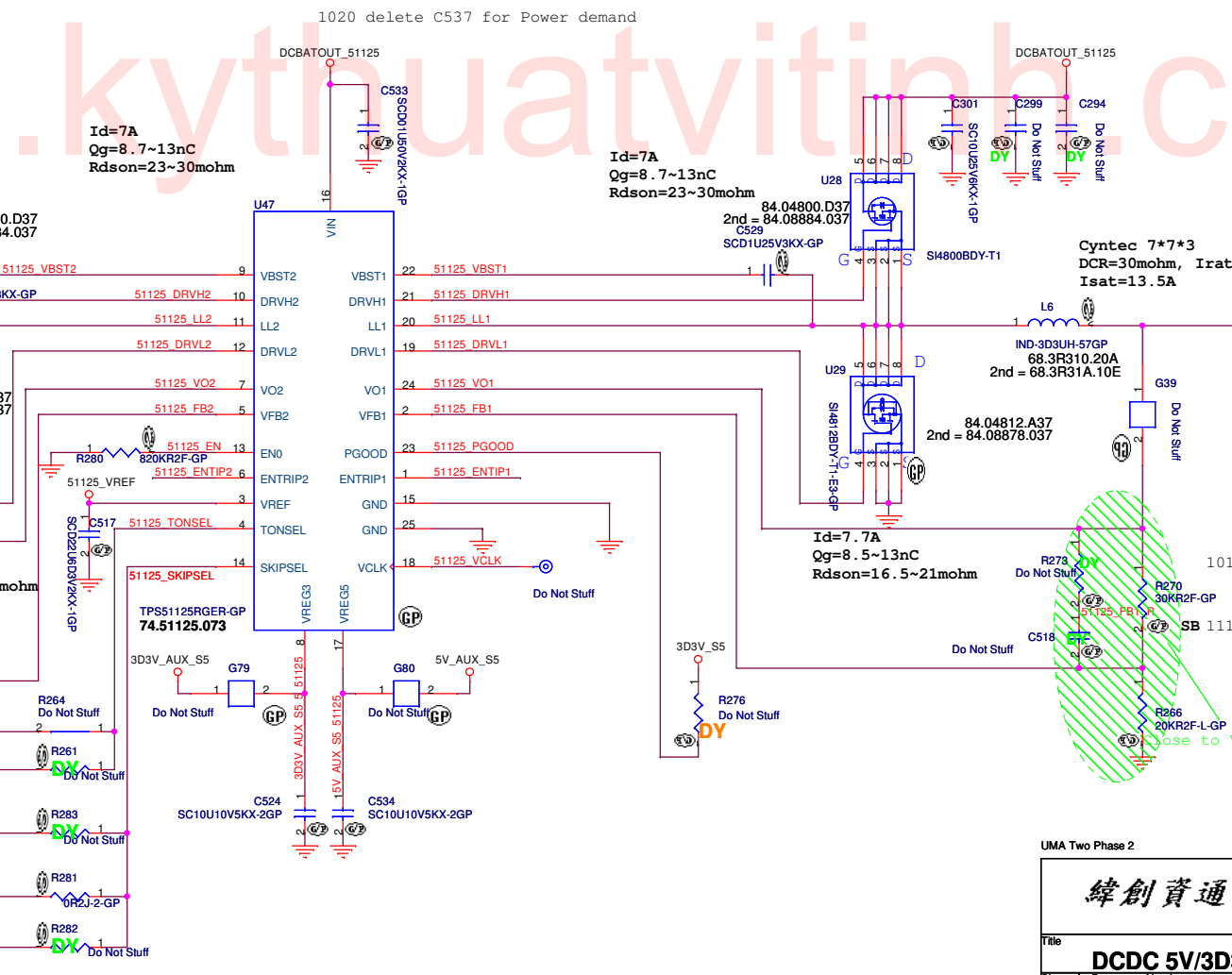

1020 delete C537 for Power demand

Id=7A
Qg=8.7~13nC
Rdson=23~30mohm

Id=7A
Qg=8.7~13nC
Rdson=23~30mohm

Cyntec 7*7*3
DCR=30mohm, Irating=6A
Isat=13.5A

Iomax=5A

84.04812.A37
2nd = 84.08878.037

Id=7.7A
Qg=8.5~13nC
Rdson=16.5~21mohm

1013 modify TC11 and add TC12

SB 1118 delete TC12

UMA Two Phase 2

緯創資通 Wistron Corporation
21F, 88, Sec.1, Hsin Tai Wu Rd., Hsichih, Taipei Hsien 221, Taiwan, R.O.C.

Title: **DCDC 5V/3D3V (TPS51125)**

Size A3 Document Number **HM40-MV** Rev **SB**

Date: Monday, December 01, 2008 Sheet 42 of 51

1D5V_S0 I_{omax}=2.5A

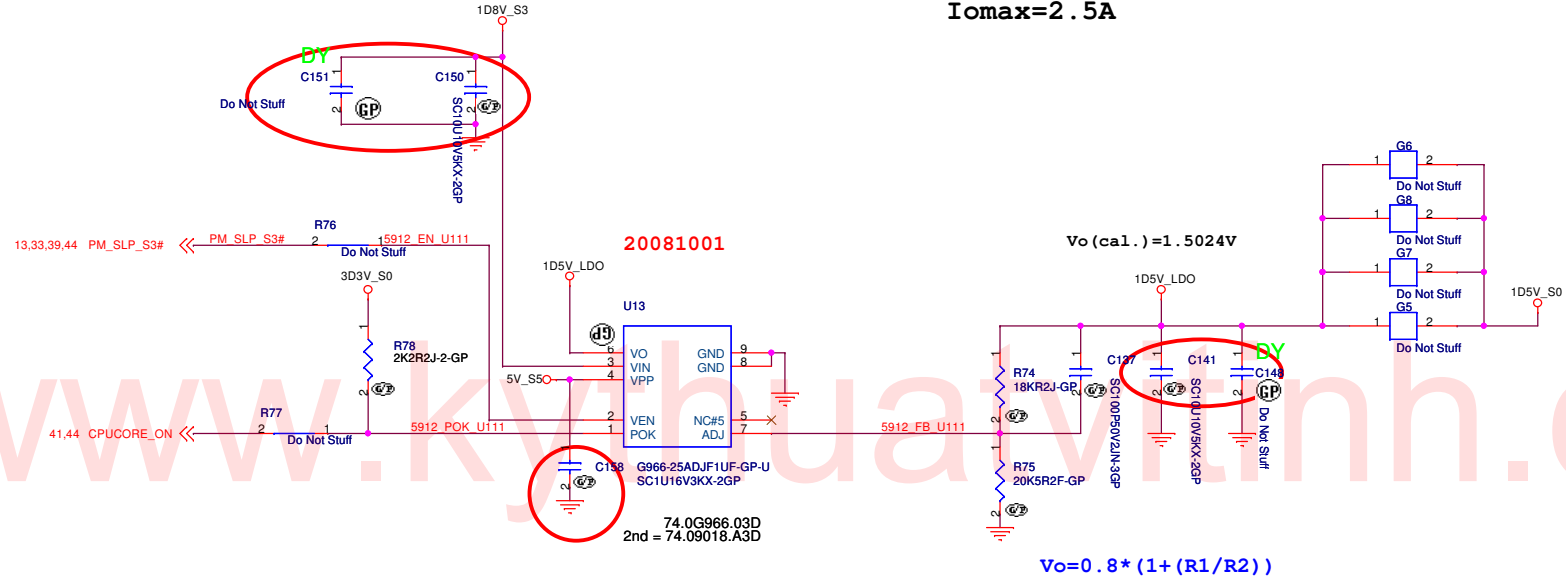

20081001

I_{omax}=1A
OCP>2A

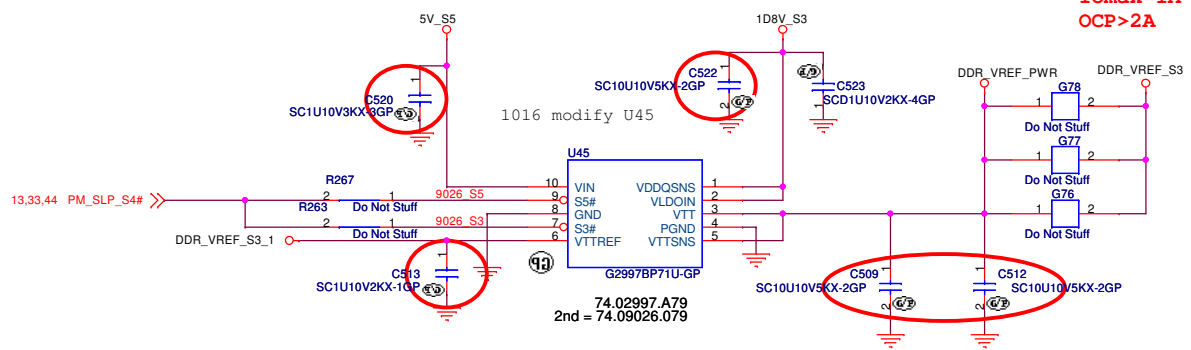

UMA Two Phase 2

緯創資通 Wistron Corporation
21F, 88, Sec.1, Hsin Tai Wu Rd., Hsichih, Taipei Hsien 221, Taiwan, R.O.C.

File: **1D5V & 0D9V**

Size A3	Document Number HM40-MV	Rev SB
Date: Monday, December 01, 2008	Sheet 43 of	51

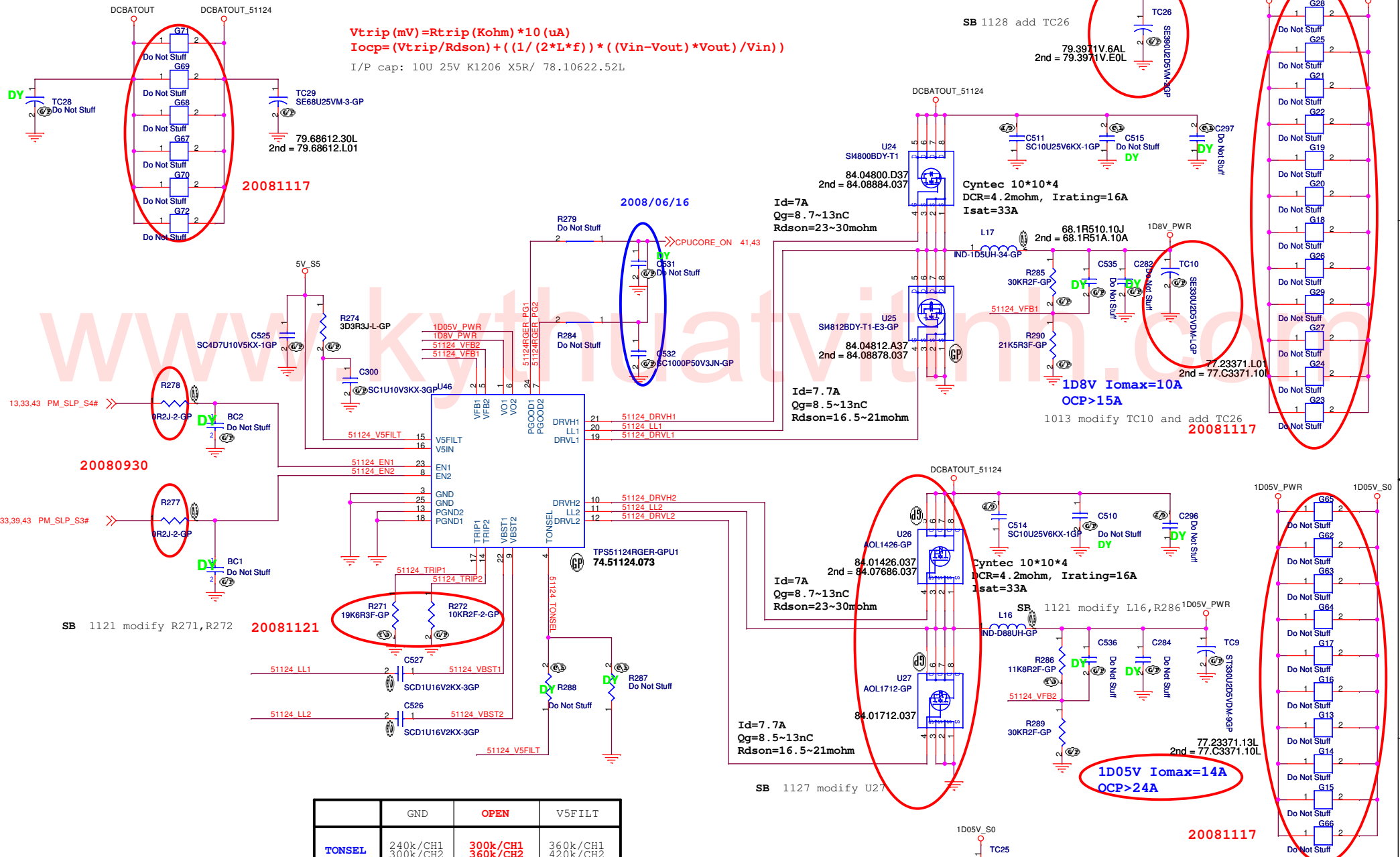

	GND	OPEN	V5FILT
TONSEL	240k/CH1 300k/CH2	300k/CH1 360k/CH2	360k/CH1 420k/CH2

Vout=0.758V*(R1+R2)/R2 --> PWM mode
 Vout=0.764V*(R1+R2)/R2 --> Skip Mode

UMA Two Phase 2

緯創資通 **Wistron Corporation**
 21F, 88, Sec. 1, Hsin Tai Wu Rd., Hsichih,
 Taipei Hsien 221, Taiwan, R.O.C.

File: **TPS51124 1D8V 1D05V**

Size A3	Document Number HM40-MV	Rev SB
Date: Friday, November 28, 2008	Sheet 44 of 51	

Adaptor in to generate DCBATOUT

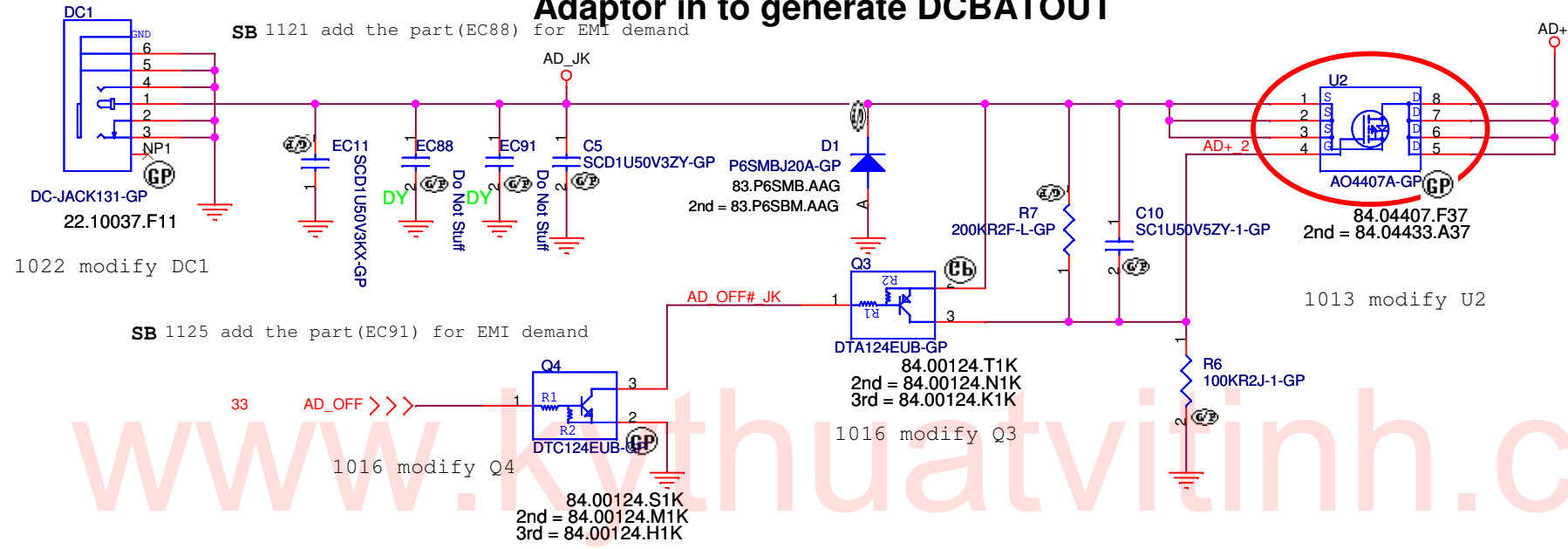

BATTERY CONNECTOR

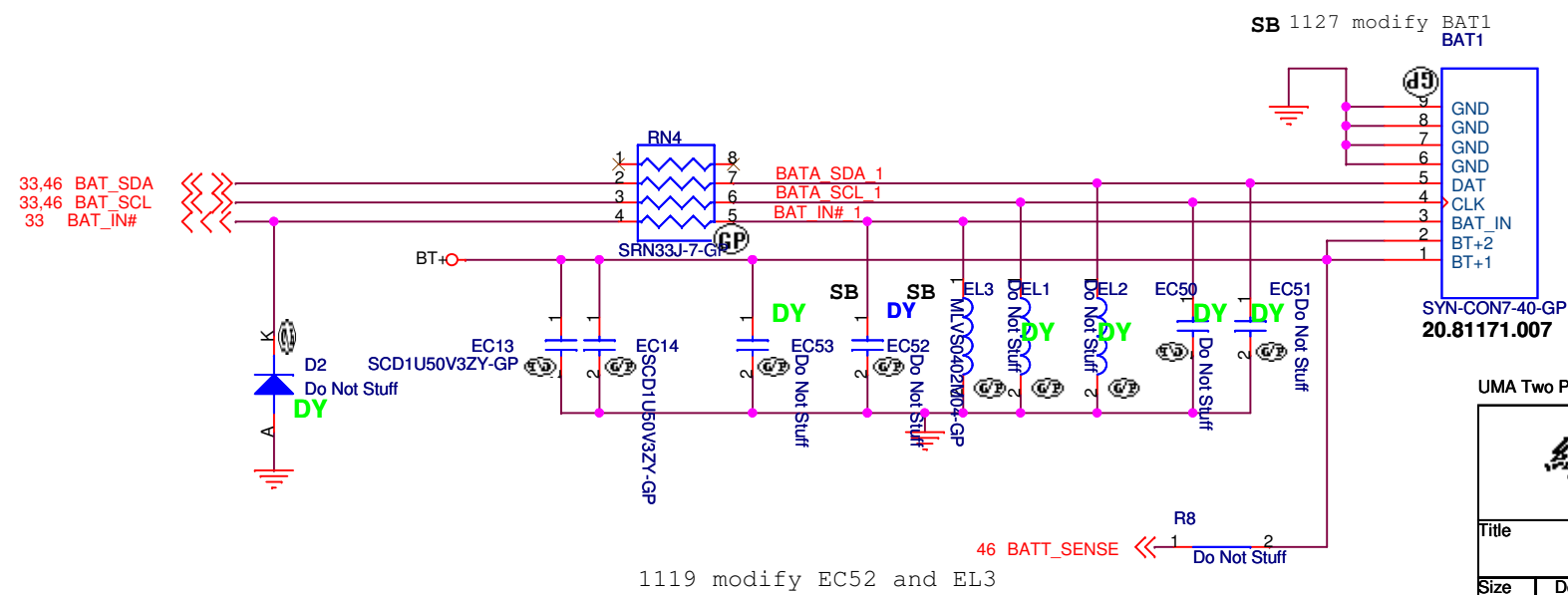

UMA Two Phase 2

緯創資通		Wistron Corporation	
21F, 88, Sec.1, Hsin Tai Wu Rd., Hsichih, Taipei Hsien 221, Taiwan, R.O.C.			
Title AD/BATT CONN			
Size	Document Number HM40-MV		Rev SB
Date:	Monday, December 01, 2008	Sheet	45 of 51

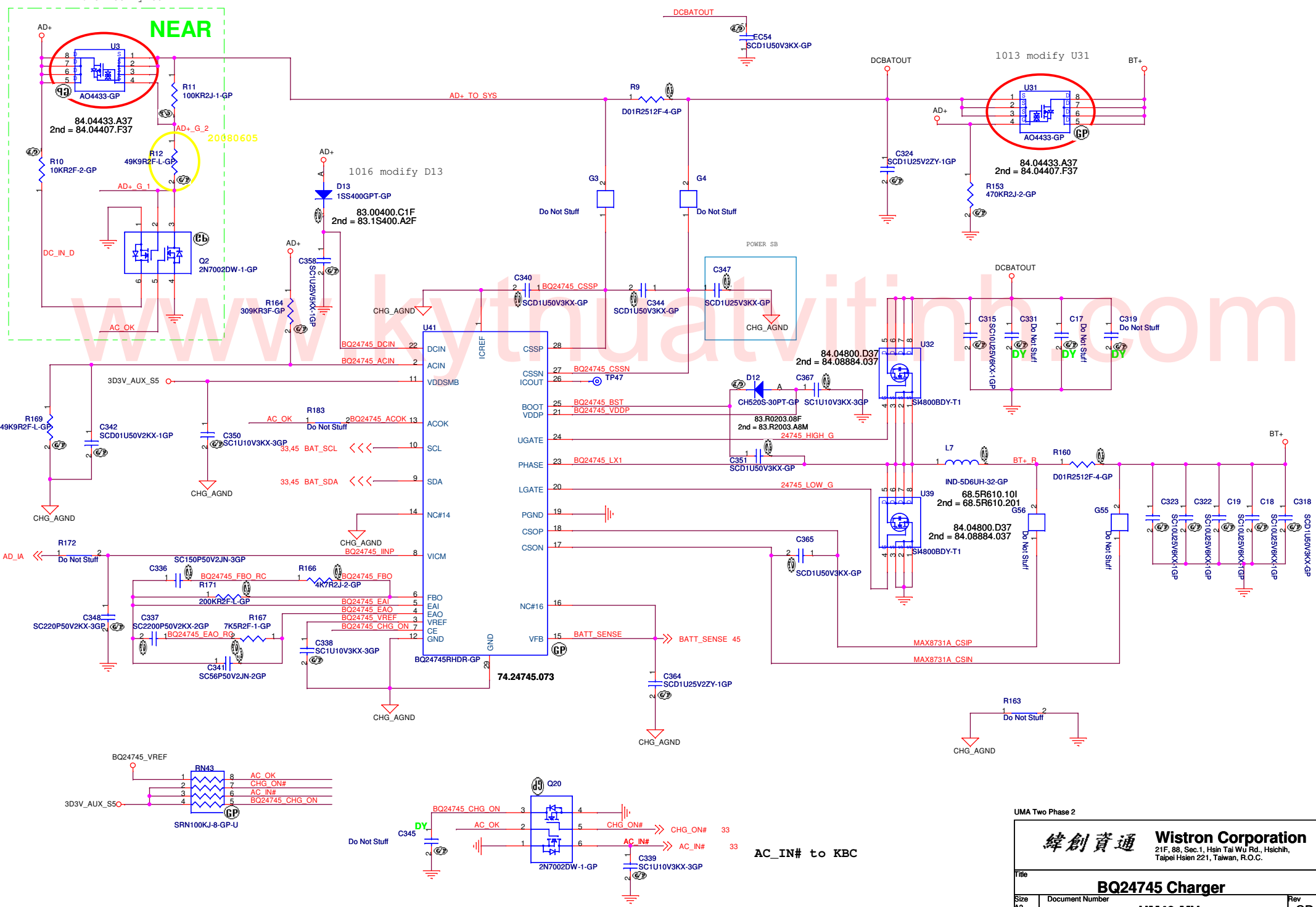

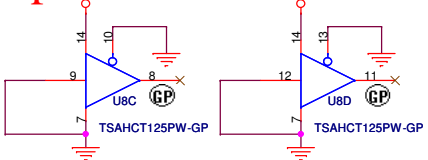

73.74125.L13
2nd = 73.74125.L12

73.74125.L13
2nd = 73.74125.L12

1016 modify U32

1017 add these parts (EC10, EC12, EC15~EC17, EC86) for EMI demand

1020 add the part (EC86) for EMI demand 1125 add the part (EC90) for EMI demand
SB 1121 add the part (EC89) for EMI demand 1128 add EC94, EC95 for EMI demand

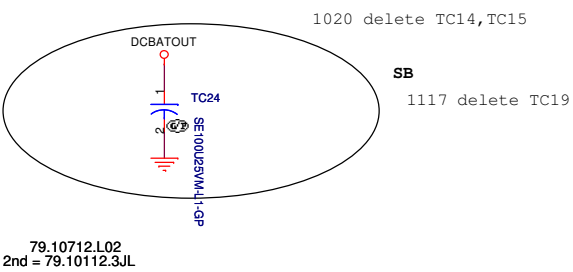

79.10712.L02
2nd = 79.10112.3JL

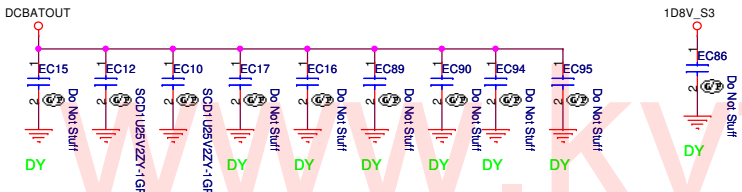

1016 add GND1 and GND2 for EMI demand
1017 add GND3 and modify GND2 for EMI demand

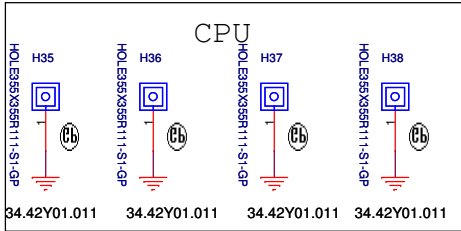

1016 modify H35-H38
1016 delete H9-H12

1016 modify H31 and H32
SB 1120 remove H31 and H32

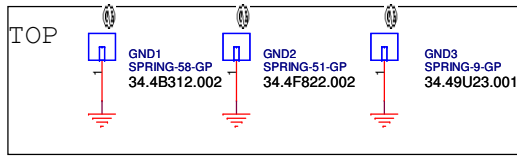

SB 1128 Add GND4, GND7, GND8

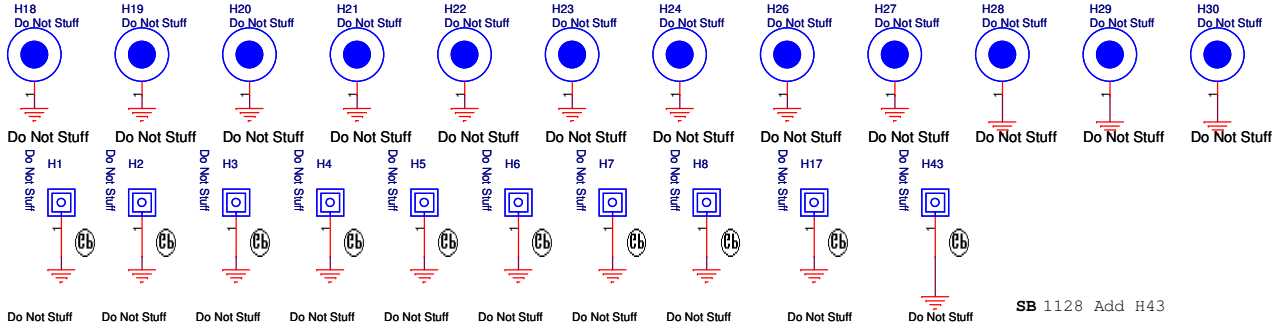

SB 1128 Add H43

Speaker



Touch pad



Keyboard



Bluetooth



1017 modify USB signal connection

LED

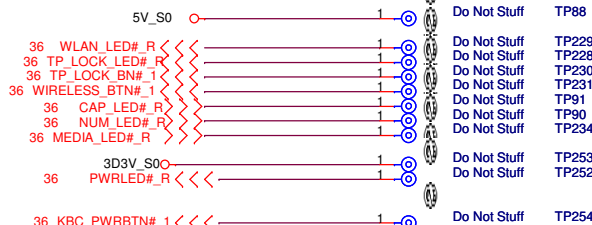

SB

1112 remove the signal(STDBY_LED#_R)

Battery



Check test point

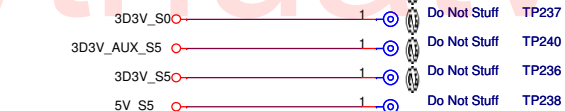

Test Point放在Dimm Door打開可量測處

FAN



UMA Two Phase 2

緯創資通 Wistron Corporation
 21F, 88, Sec.1, Hsin Tai WJ Rd., Hsichih,
 Taipei Hsien 221, Taiwan, R.O.C.

Title		
AFTE test point		
Size	Document Number	Rev
	HM40-MV	SB
Date:	Monday, December 01, 2008	Sheet 48 of 51

0910 delete F4(Page 18)
 0910 update footprint of U15(Page 30)
 0910 delete RIGHT1 and LEFT1(Page 33)
 0910 modify net names of TP_LEFT and TP_RIGHT(Page 36)
 0910 modify test points of AFTE and TPAD
 0911 modify net name from LPC_RST to PLT_RST1#(Page 24)
 0911 add net name(RBIAS,LED_DUPLEX#,SMDATA,SMCLK)(Page 24)
 0911 add net name(DVDD_1_8,ACZ_SDATAIN0_R,FLY_P,FLY_N,VREF_LO,VREF_HI)(Page 26)
 0911 add net name(EAPD#_R)(Page 27)
 0912 modify the schematic of Page 33
 0912 delete GMCH_TXB*(Page 7& 18)
 0912 add these parts for EMI demand(page 7,18,20,21,23,26,28,29,30,32,33,34,35)
 0915 modify net name from 10M/100M/1G_LED# to 10M/100M_LED#(page24,25)
 0915 delete these parts for EMI demand(page 30)
 0915 add EC34 for EMI demand(page3)
 0915 add EC73 for EMI demand(page 12)
 0915 modify LEDs port
 0916 move net (SPI_WP#) from U9 pin120 to pin25(page33)
 0930 modify BLUE1(page22)
 0930 add 2nd for SPK1, MIC1 and modify LOUT1 (page28)
 0930 modify FAN1(page32)
 0930 modify TPAD1(page35)
 0930 modify KB1(page33)
 0930 modify net name for BIOS demand(page33)
 1001 delete these parts for EMI demand(ED1~8)
 1009 modify net name for GND to AGND(page27)
 1009 add R4,R5 for AC decoupling(page27)
 1009 add R96(page30)
 1013 modify TPAD1(page35)
 1013 modify U40 from 72.25X16.001 to 72.25X16.A01(page 34)
 1013 modify TC11 and add TC12(page42)
 1013 modify TC10 and add TC26(page44)
 1013 modify U2(page45)
 1013 modify U3 and U31(page 46)
 1013 modify R161 and R162(page41)
 1013 modify card1(page 30)
 1014 modify these LEDs(LED11,LED12)(page38)
 1014 modify these nets(page 26)
 1014 modify R258 from 10k to 20k ohm(page26)
 1014 add ER5 for EMI deamnd(page3)
 1015 modify LCD1 pin define(page 18)
 1015 modify the power from 3D3V_S5 to 5V_S5(page38)
 1015 modify TPAD1(page35)
 1015 modify RN57(page28)
 1015 modify F1(page18)

UMA Two Phase 2			
緯創資通		Wistron Corporation	
		<small>21F, 88, Sec.1, Hsin Tai Wu Rd., Hsichih, Taipei Hsien 221, Taiwan, R.O.C.</small>	
Change List			
Size	Document Number	Rev	
	HM40-MV	SB	
Date: Monday, November 24, 2008		Sheet 49	of 51

- 1016 modify L1,L2 and L3(page 19)
- 1016 modify XF1(page 25)
- 1016 modify RN53 and U10(page 24)
- 1016 modify U8 (page19,47)
- 1016 modify U4(page 37)
- 1016 modify U23(page 43)
- 1016 modify X2(page12)
- 1016 modify X1(page 33)
- 1016 modify X3(page 3)
- 1016 modify D13(page 46)
- 1016 modify D23(page 20)
- 1016 modify D9(page 39)
- 1016 modify D4(page 19)
- 1016 modify Q3 and Q4(page45)
- 1016 modify Q18(page 36)
- 1016 modify Q15~Q17(page 36)
- 1016 modify Q27~Q30(page38)
- 1016 modify Q6 and Q14(page 32)
- 1016 modify Q8(PAGE 24)
- 1016 add GND1 nad GND2 for EMI demand(page 47)
- 1016 modify LCD1 pin define(page 18)
- 1016 delete H9-H12 and modify H35-H38,H31,H32(page 47)
- 1017 add these parts for EMI demand(page 47)
- 1017 delete these parts(EC208~EC210) (page 7)
- 1017 modify BLUE1(page 22)
- 1017 modify FAN1 (page 32)
- 1017 modify R291 and R293(page 38)
- 1017 add U61,R52,EC23 and EC24(page 37)
- 1017 modify RN60(page37)
- 1017 add TC25(page 44)
- 1017 add GND3 and modify GND2 for EMI demand(page 47)
- 1017 modify USB signal connection(page13,18,22,23,30,31,48)
- 1020 delete C537 for Power demand(page42)
- 1020 add the part(EC86) for EMI demand(page 47)
- 1020 delete U61,R52,EC24 and EC23(page 37)
- 1020 delete TC14,TC15(page 47)
- 1021 modify TC16(page 31)
- 1021 delete TC23(page 23)
- 1021 modify TC5(page 20)
- 1021 modify and swap these parts(USB1 and USB2) (page 23)
- 1021 modify SATA1(page 20)
- 1022 modify DC1(page 45)

www.kythuativinh.com

UMA Two Phase 2			
緯創資通		Wistron Corporation	
		<small>21F, 88, Sec.1, Hsin Tai Wu Rd., Hsichih, Taipei Hsien 221, Taiwan, R.O.C.</small>	
Change List			
Size	Document Number	Rev	
	HM40-MV	SB	
Date:	Monday, November 24, 2008	Sheet	50 of 51

1106 modify net connection of RN46 and RN44(page33) for layout demand
 1106 modify LED11 and LED12(page38) for fixing issue
 1106 modify LED power from 5V_S5 to 5V_AUX_S5(page38) for customer demand
 1112 remove the signal(STDBY_LED#_FR)page38 for customer demand
 1112 remove these signals(STDBY_LED#_FR and STDBY_LED#_R) and R131(page36) for customer demand
 1112 remove the signal(STDBY_LED#_R)page36 for customer demand
 1112 remove the signal(STDBY_LED#_R)and TP253(page48) for customer demand
 1113 modify C103 and C106(page24) for crystal issue
 1113 modify 2nd of U19(page26)
 1113 modify 2nd of U43(page39)
 1113 modify 2nd of U44(page10)
 1113 modify U48(page22)
 1117 delete MDC function(R231,R237,R232,R234) (page12)
 1117 delete TC19(page 47) for ME deamnd
 1118 modify PCB Ver. from SA to SB(page33)
 1118 delete TC12(page42) for layout demand
 1118 delete TC27(page9) for layout demand
 1118 delete R107 and add L18 for cost down
 1119 modify R130 and R133(page 36) for LED brightness
 1119 modify EC52 and EL3(page45) for EMI demand
 1119 modify SPK1(page 28) for ME deamnd
 1119 add G84 for RTC reset demand
 1120 modify EC78for EMI demand((page10)
 1120 modify PowerCN1 pin3 and remove EC44(page36) fro LED function
 1120 remove H31 and H32(page47)for ME demand
 1120 add RN61 and RN62(page3) for layout demand
 1120 swap these nets(CLK_MCH_3GPLL,CLK_MCH_3GPLL#, CLK_PCIE_MINI1,CLK_PCIE_MINI1#) (page3)for CLK REQ demand
 1120 add the net(SATACLKREQ#) (page3,13)for CLK REQ demand
 1120 move these nets (CLK_PCIE_MINI1,CLK_PCIE_MINI1#) (page3)for CLK REQ demand
 1120 modify RN61 and RN62(page3)for CLK REQ demand
 1121 add EC87 for EMI demand(page18)
 1121 add the part(EC89) for EMI demand(page47)
 1121 add the part(EC88) for EMI demand(page45)
 1121 modify R18,C43(page41) for Power demand
 1121 modify R275 (page42)for Power demand
 1121 modify R271,R272,R286 and L16(page44) for Power demand
 1124 modify U42 and delete R182,R185 (page32) for thermal function
 1124 modify these names of these nets(G7922_SGND2,G7922_SGND3...) (page32) for thermal function
 1124 add R302(page3) for clock gen function
 1125 add the part(EC90) for EMI demand(page47)
 1125 add the part(EC91) for EMI demand(page45)
 1125 modify R125,R126(page18) for LCD brightness control
 1125 modify RN40 and delete RN42(page32) for layout demand
 1125 add EC92 and EC93 for EMI demand(page 22)
 1126 add these nets (PCIE_REQ_LAN#,PCIE_REQ_MINI#) (page3)for CLK REQ demand
 1126 delete R230,R233,R235,R236 and RN63(page12) for removing MDC function
 1126 add C541 and modify R101(page26) for codec function
 1126 modify RN61 and RN62(page3) for layout demand
 1126 modify EU1,EU2 and add EU3,EU4 for EMI demand(page28)
 1127 modify CRT1(page19) for customer demand
 1127 swap the nets of RN61 and RN62 for layout demand(page3)
 1127 modify BAT1(page45) for ME demand
 1127 modify U27(page44) for power demand

1127 modify C377(page32) for thermal function
 1128 Add H43,GND4,GND7,GND8(page47) for EMI demand
 1128 modify LCD1(page18) for cost down
 1128 Add L19(page24) for vender demand
 1128 add EC94,EC95 for EMI demand(page47) demand

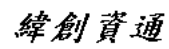

UMA Two Phase 2			
		Wistron Corporation 21F, 88, Sec.1, Hsin Tai Wu Rd., Hsichih, Taipei Hsien 221, Taiwan, R.O.C.	
Change List			
Size	Document Number	Rev	
	HM40-MV	SB	
Date:	Monday, December 01, 2008	Sheet	51 of 51