

San Antonio 10EJV

PreMP BUILD 0307

DATE	CHANGE NO.	REV

DRAWER	EE	DATE	POWER	DATE	INVENTEC					
DESIGN					TITLE SA10EJV					
CHECK					SIZE = 3					
RESPONSIBLE					FILE NAME: XXXX-XXXXXX-XX	VER:	SIZE A3	CODE CS	DOC. NUMBER	REV A02
					P/N: XXXXXXXXXXXX		SHEET	1	OF	51

TABLE OF CONTENTS

PAGE		PAGE	
1.	COVER PAGE	32.	RTC
2.	INDEX	33.	CARDBUS CONTROLLER
3.	BLOCK DIAGRAM	34.	PCMCIA & EXPRESS CARD
4.	POWER SEQUENCE BLOCK	35.	5 IN 1 MEMORY CARD
5-11.	SYSTEM POWER	36.	1394 CONTROLLER
12.	CLOCK GENERATOR	37.	MINIPCI CONN
13.	CPU(1/4)	38.	LAN CONTROLLER
14.	CPU(2/4)	39.	RJ45 & TRANSFORMER
15.	CPU(3/4)	40.	HDD CONN
16.	CPU(4/4)	41.	ODD CONN
17.	FAN&THERMAL CONTROLLER	42.	USB CONN
18.	N/B(1/5)	43.	SUPER I/O
19.	N/B(2/5)	44.	K/B & D/B CONN
20.	N/B(3/5)	45.	AC97 CODEC
21.	N/B(4/5)	46.	AUDIO AMP
22.	N/B(5/5)	47.	MDC
23.	DDR2 DIMM0	48.	SWITCH & LED (MB)
24.	DDR2 DIMM1	49.	SWITCH & LED (DB)
25.	DDR2 DAMPING	50.	USB & SVIDEO BOARD
26.	CRT	51.	TP BOARD
27.	LCM		
28.	S-VIDEO		
29.	S/B(1/5)		
30.	S/B(2/5)		
31.	S/B(3/5)		

INVENTEC

TITLE SA10EJV

SIZE	CODE	DOC. NUMBER	REV
A3	CS	1310A2076701	A02

CHANGE by Kobby Wen 21-Feb-2006

SHEET 2 OF 51

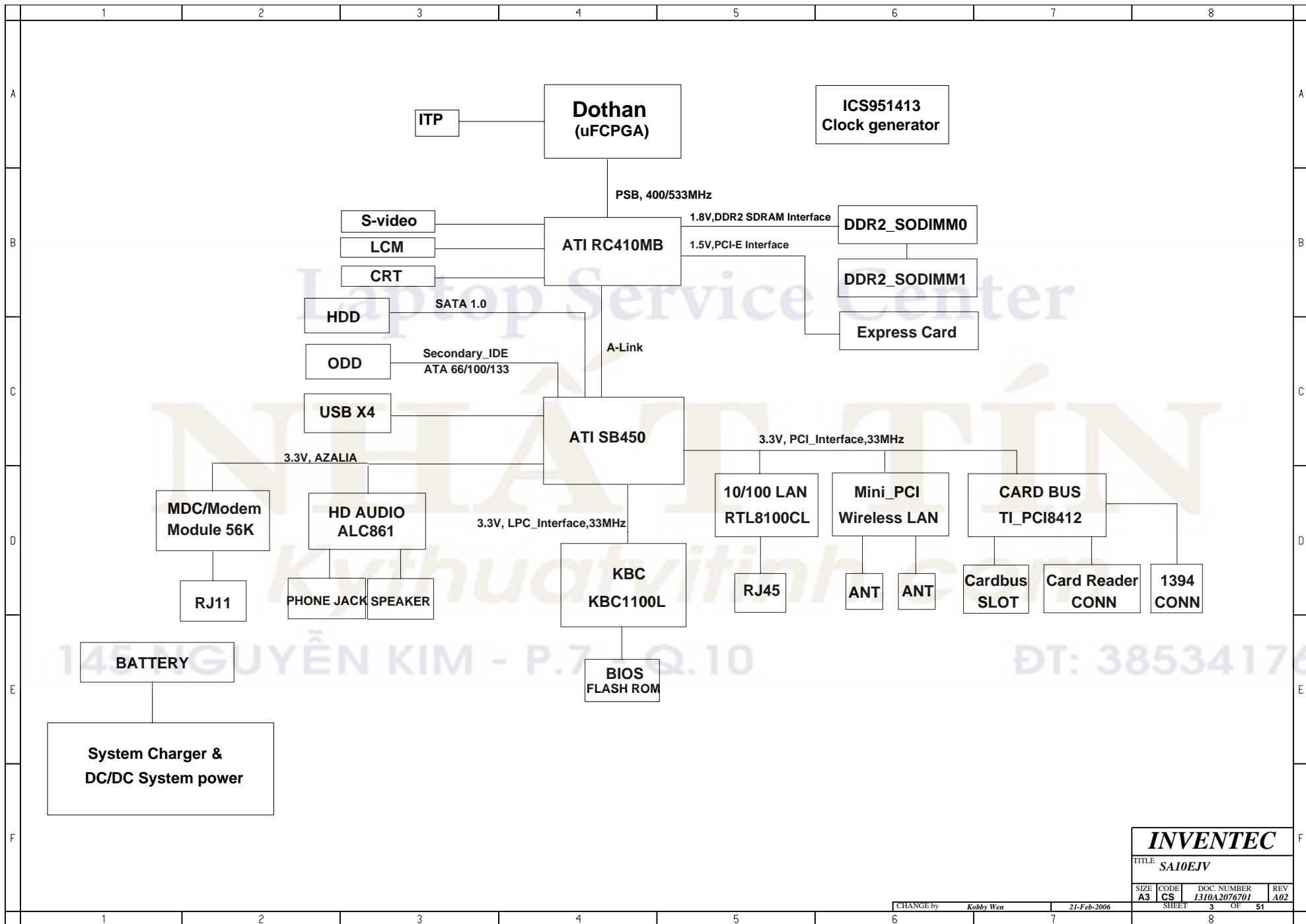

INVENTEC

TITLE			
SA10EJV			
SIZE	CODE	DOC. NUMBER	REV
A3	CS	1310A2076701	A02

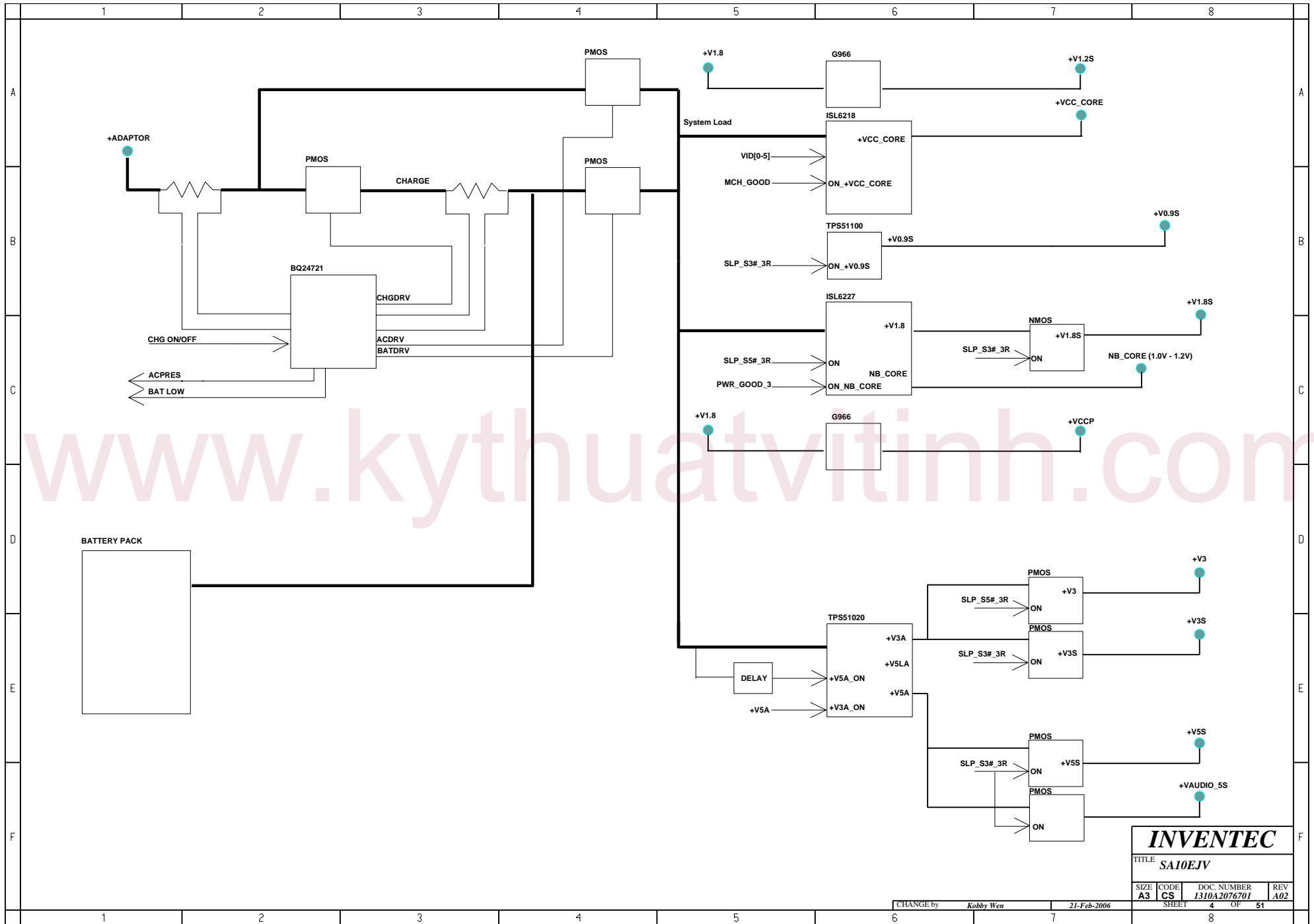

www.kythuatvithinh.com

INVENTEC			
TITLE SA10EJV			
SIZE A3	CODE CS	DOC. NUMBER 1310A2076701	REV A02

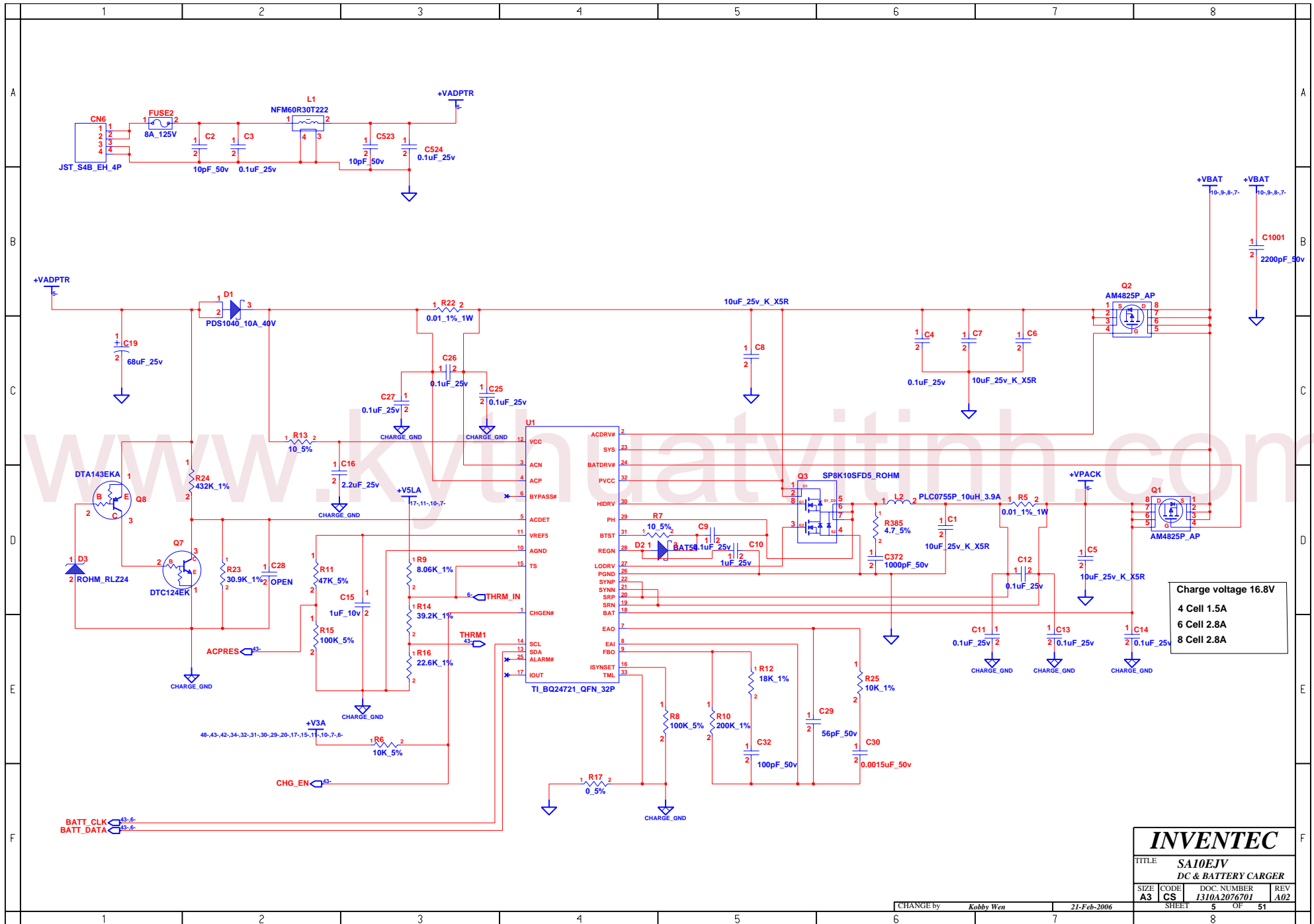

Charge voltage 16.8V
 4 Cell 1.5A
 6 Cell 2.8A
 8 Cell 2.8A

INVENTEC

TITLE			
SA10EJV			
DC & BATTERY CHARGER			
SIZE	CODE	DOC. NUMBER	REV
A3	CS	I310A2076701	A02

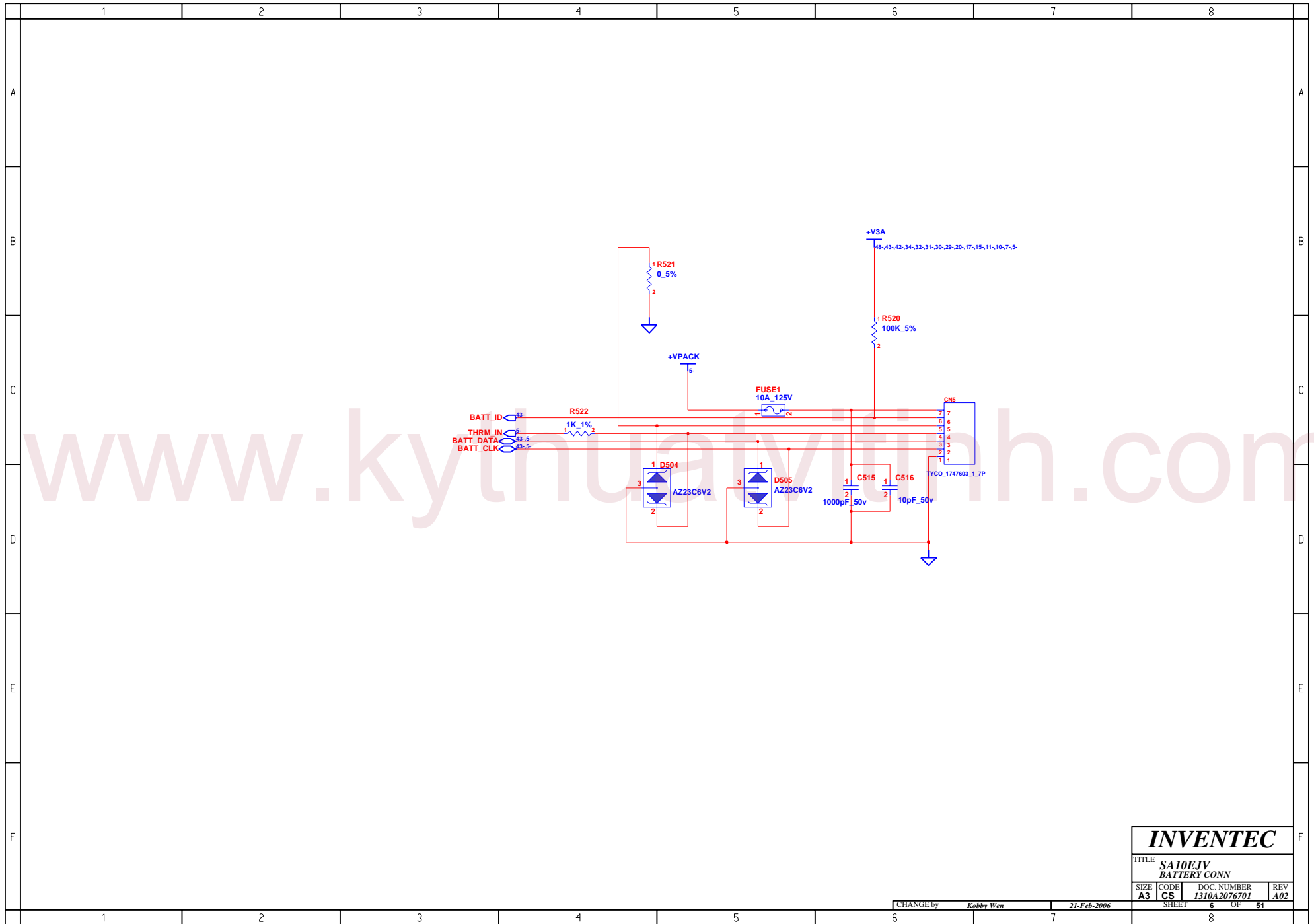

INVENTEC

TITLE
**SA10EJV
BATTERY CONN**

SIZE A3	CODE CS	DOC. NUMBER 1310A2076701	REV A02
-------------------	-------------------	------------------------------------	-------------------

CHANGE by *Kobby Wen* 21-Feb-2006

SHEET 6 OF 51

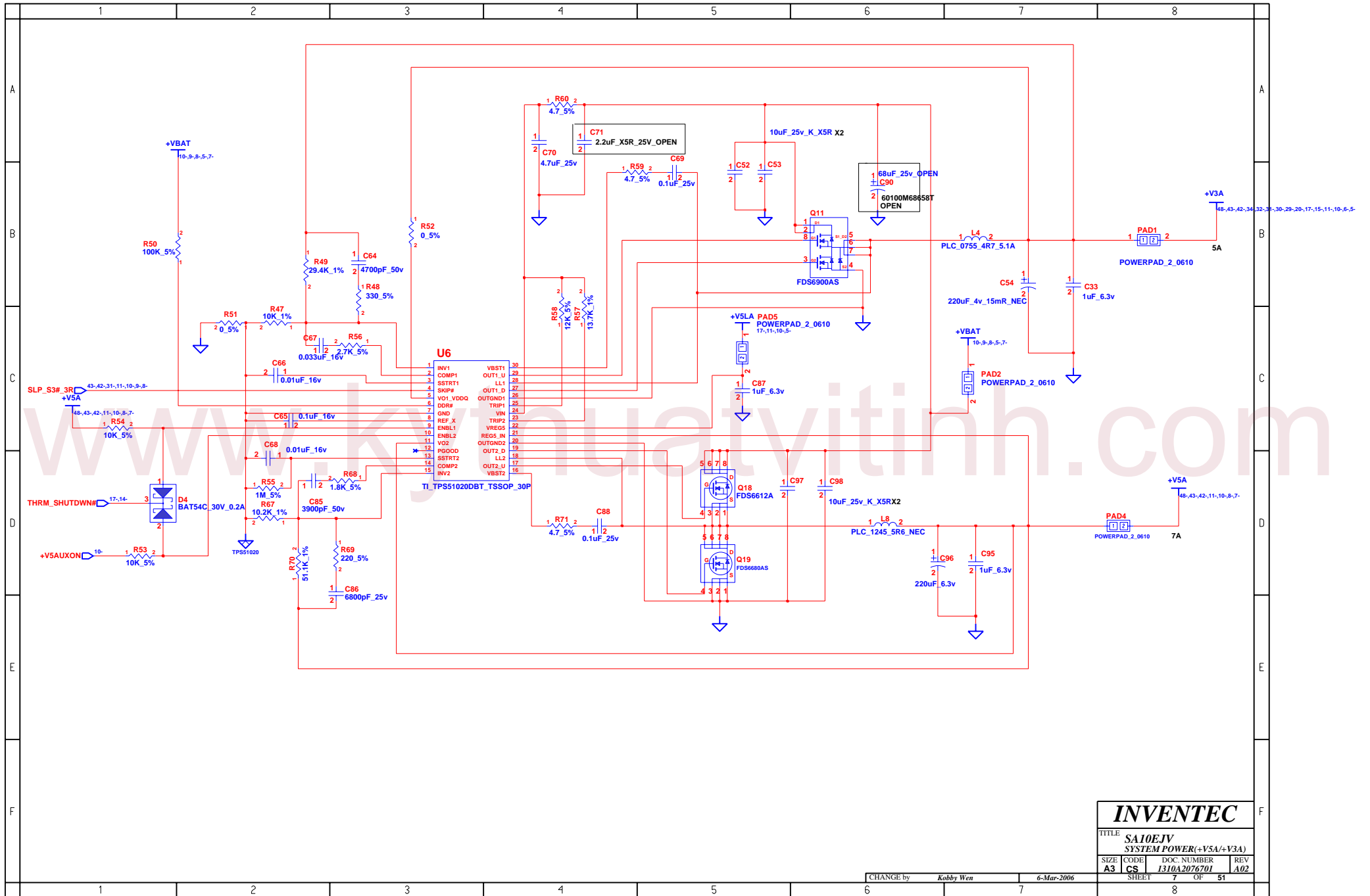

INVENTEC

TITLE SA10EJV
SYSTEM POWER(+V5A/+V3A)
SIZE A3 CODE CS DOC NUMBER 1310A2076701 REV A02

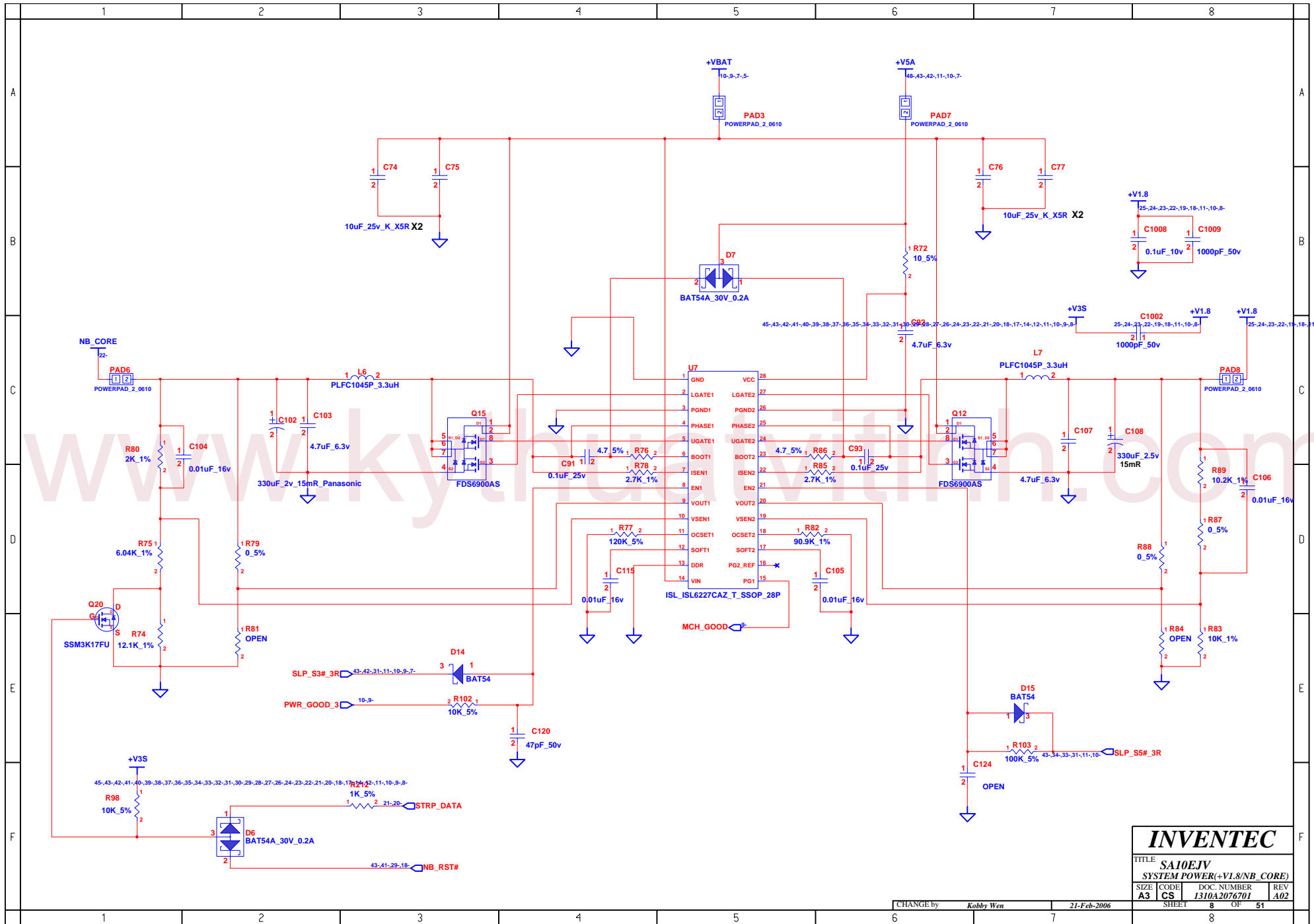

INVENTEC			
TITLE SAI0EJV			
SYSTEM POWER(+V1.8/NB_CORE)			
SIZE A3	CODE CS	DOC. NUMBER 1310A2076701	REV A02

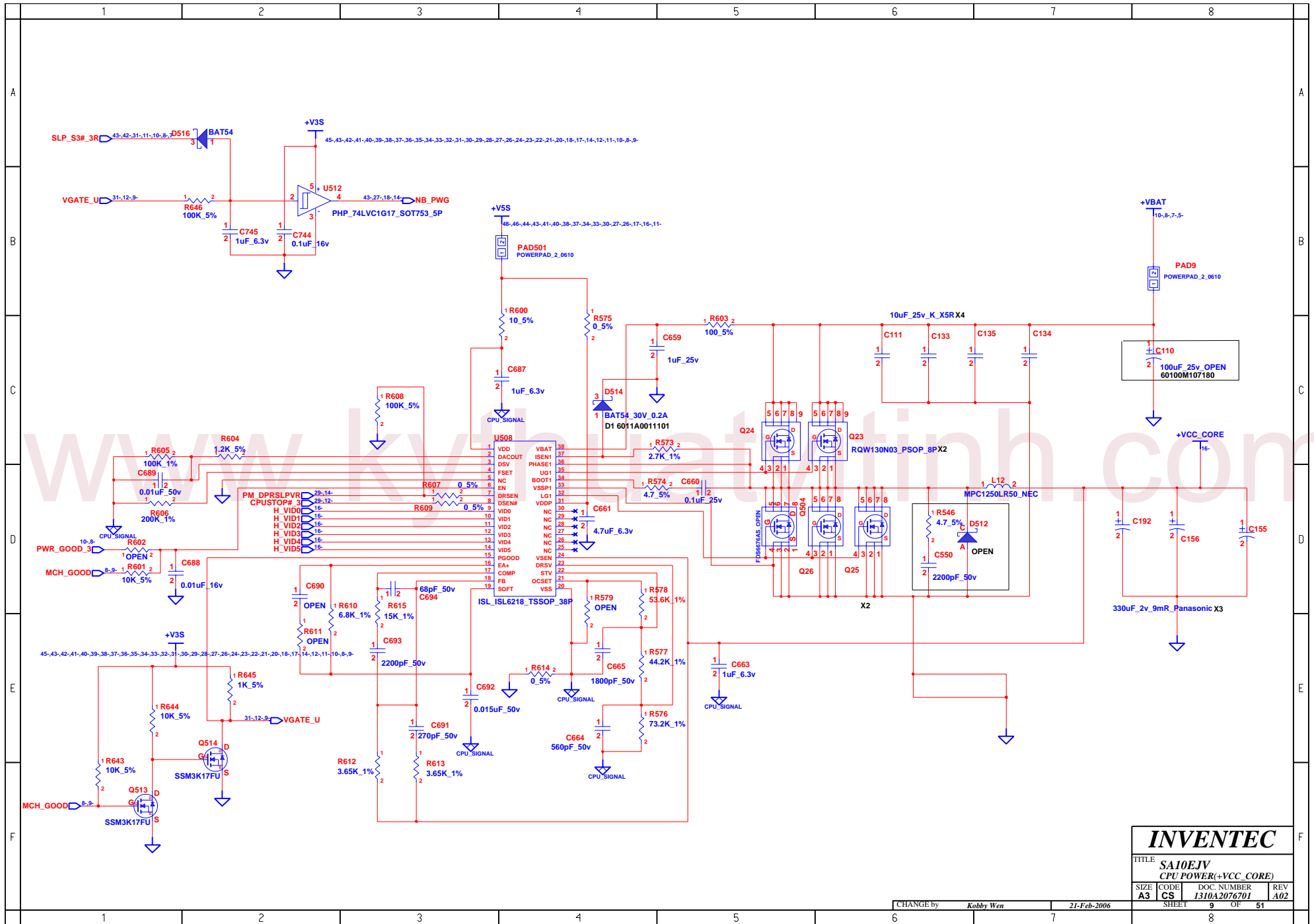

INVENTEC			
TITLE SA10EJV CPU POWER(+VCC_CORE)			
SIZE A3	CODE CS	DOC. NUMBER I310A2076701	REV A02
CHANGE by Kobby Wen		21-Feb-2006	
SHEET 9		OF 51	

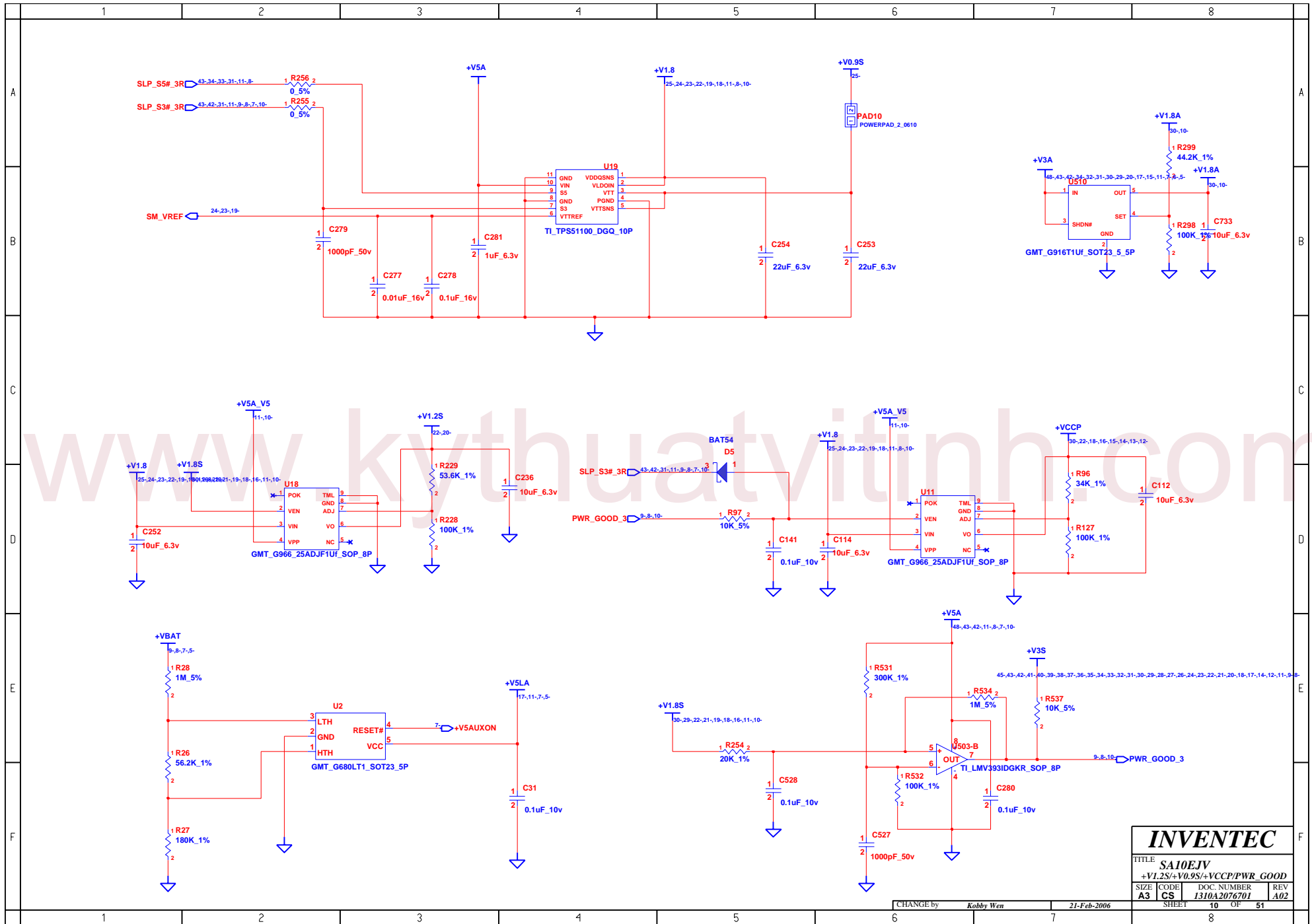

INVENTEC			
TITLE SA10EJV			
+V1.2S/+V0.9S/+VCCCP/PWR_GOOD			
SIZE A3	CODE CS	DOC NUMBER 1310A2076701	REV A02

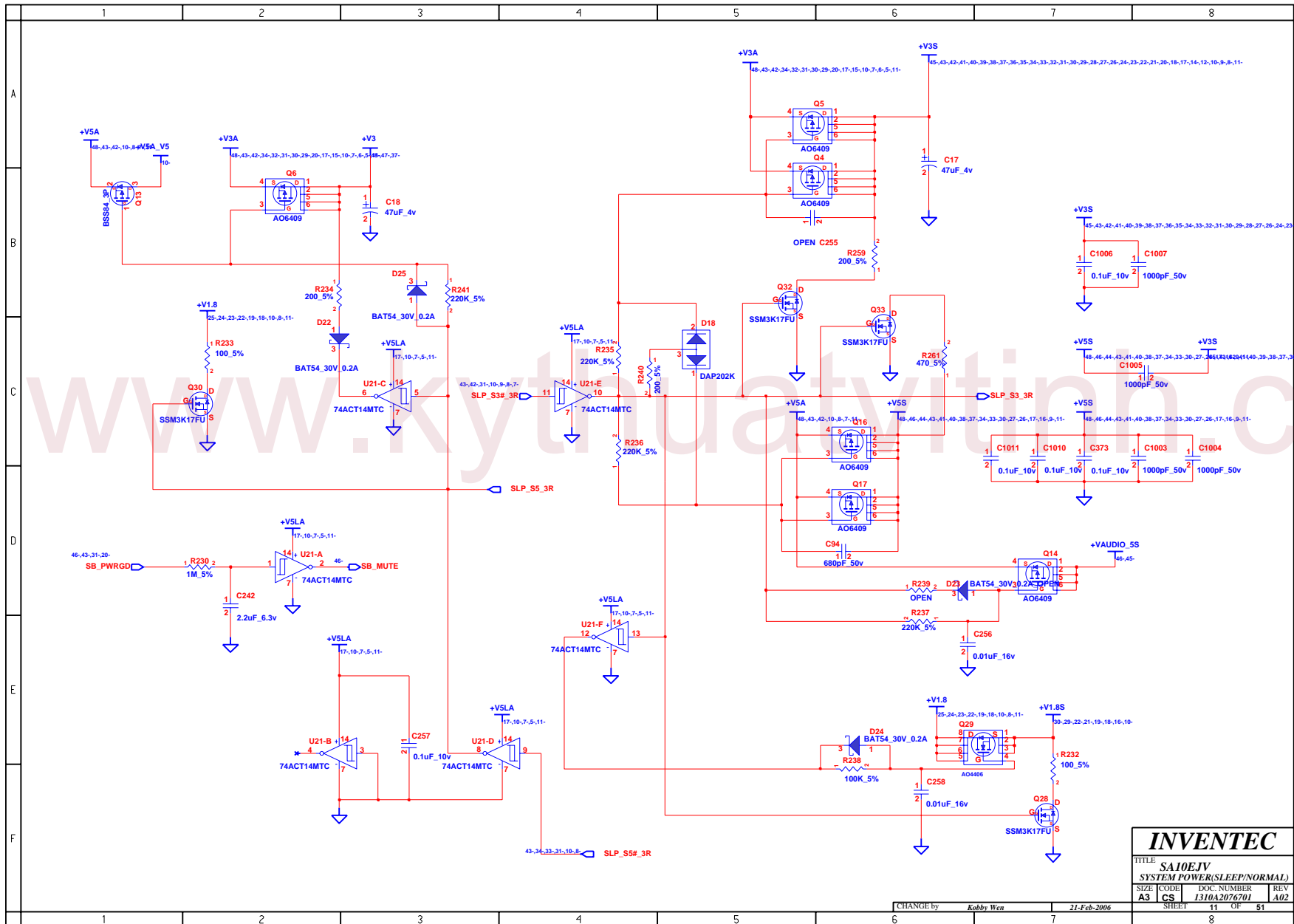

INVENTEC
TITLE SA10EJV
SYSTEM POWER(SLEEP/NORMAL)
SIZE A3 CODE CS DOC. NUMBER 1310A2076701 REV A02

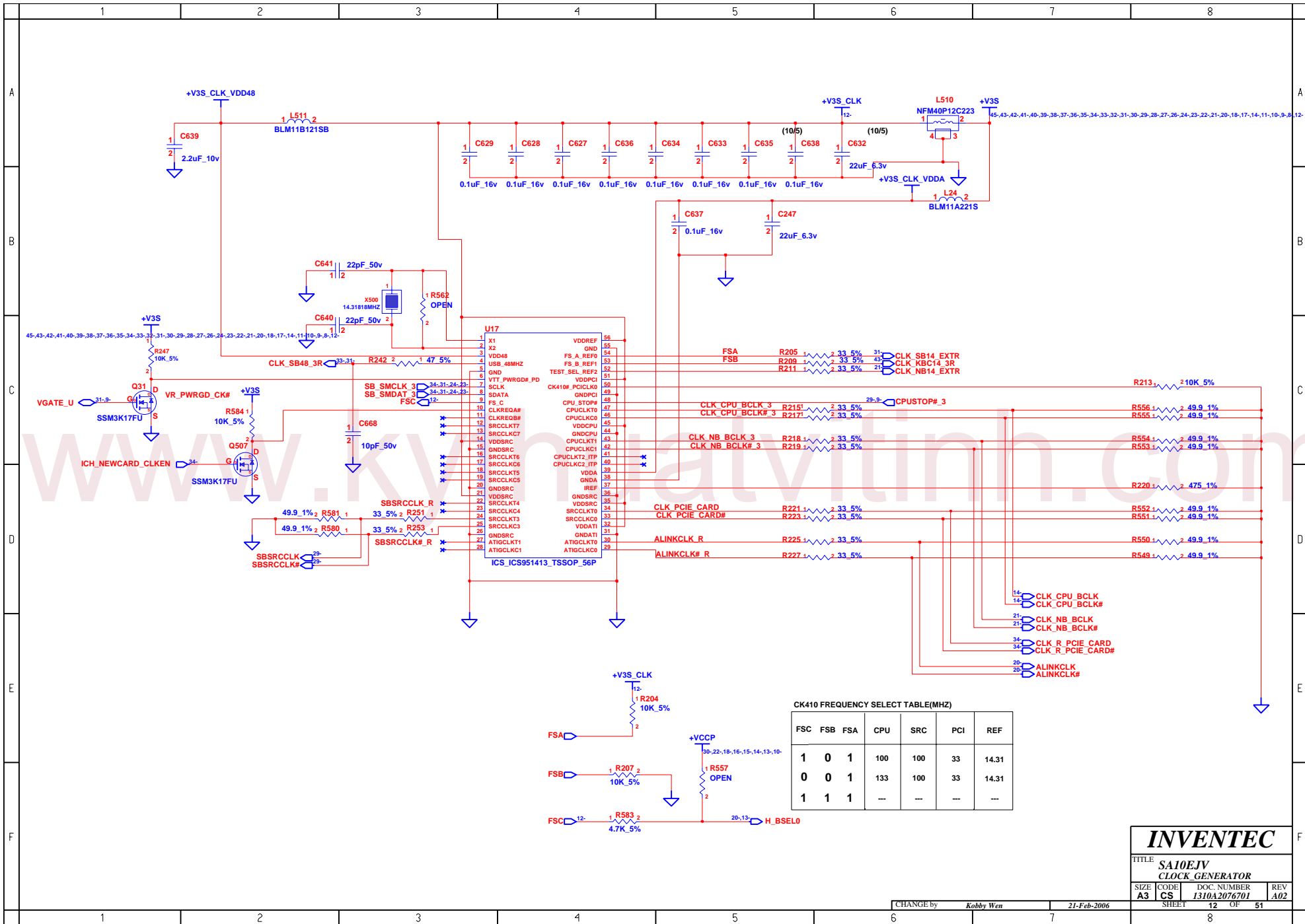

CK410 FREQUENCY SELECT TABLE(MHZ)

FSC	FSB	FSA	CPU	SRC	PCI	REF
1	0	1	100	100	33	14.31
0	0	1	133	100	33	14.31
1	1	1	---	---	---	---

INVENTEC

TITLE: **SA10EJV**
CLOCK GENERATOR

SIZE: A3	CODE: CS	DOC NUMBER: 1310A2076701	REV: A02
-----------------	-----------------	---------------------------------	-----------------

CHANGE by: *Kobby Wen* 21-Feb-2006 SHEET 12 OF 51

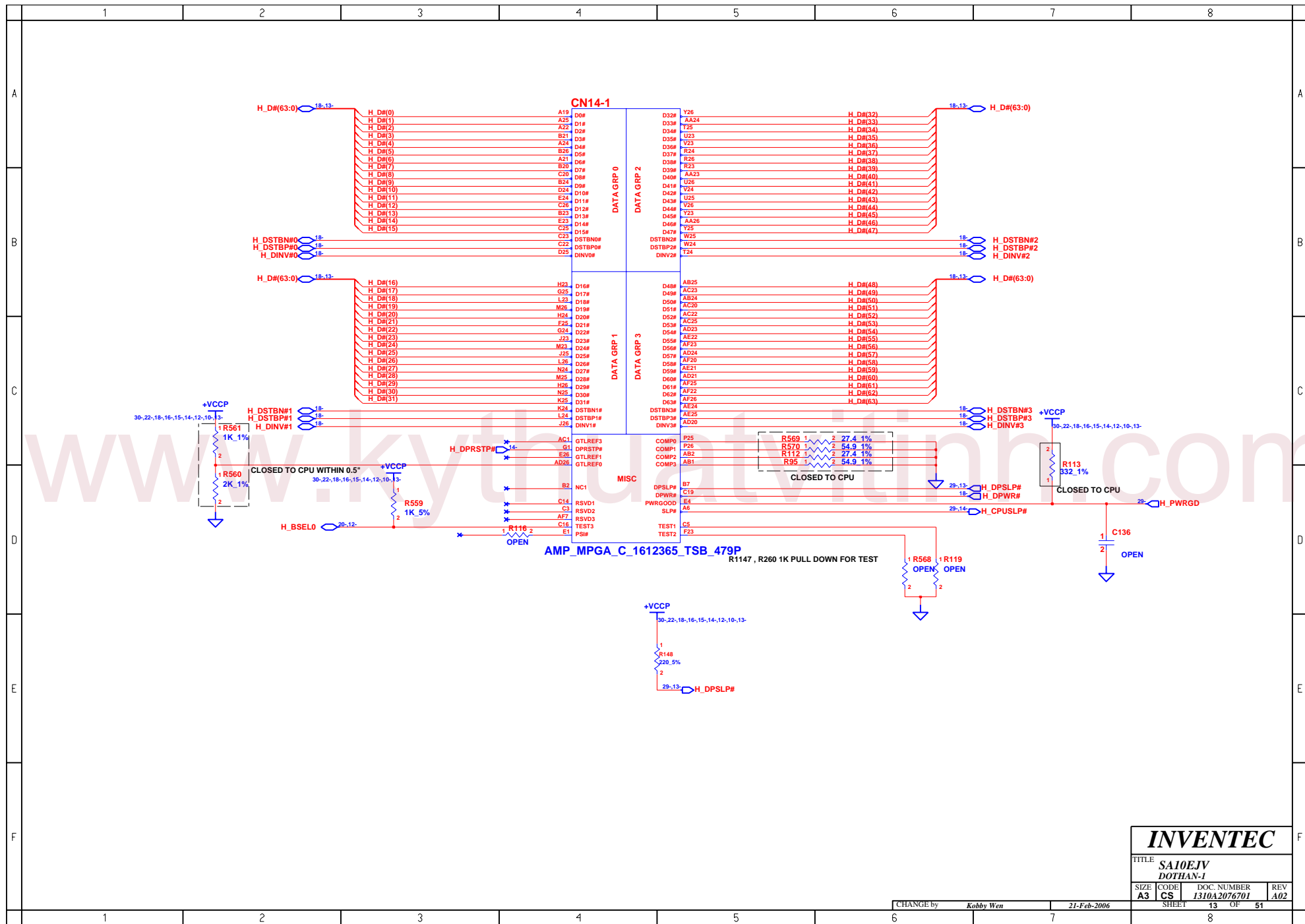

INVENTEC			
TITLE SA10EJV DOHAN-1			
SIZE A3	CODE CS	DOC. NUMBER 1310A2076701	REV A02
CHANGE by <i>Kobby Wen</i>		21-Feb-2006	
SHEET		13 OF 51	

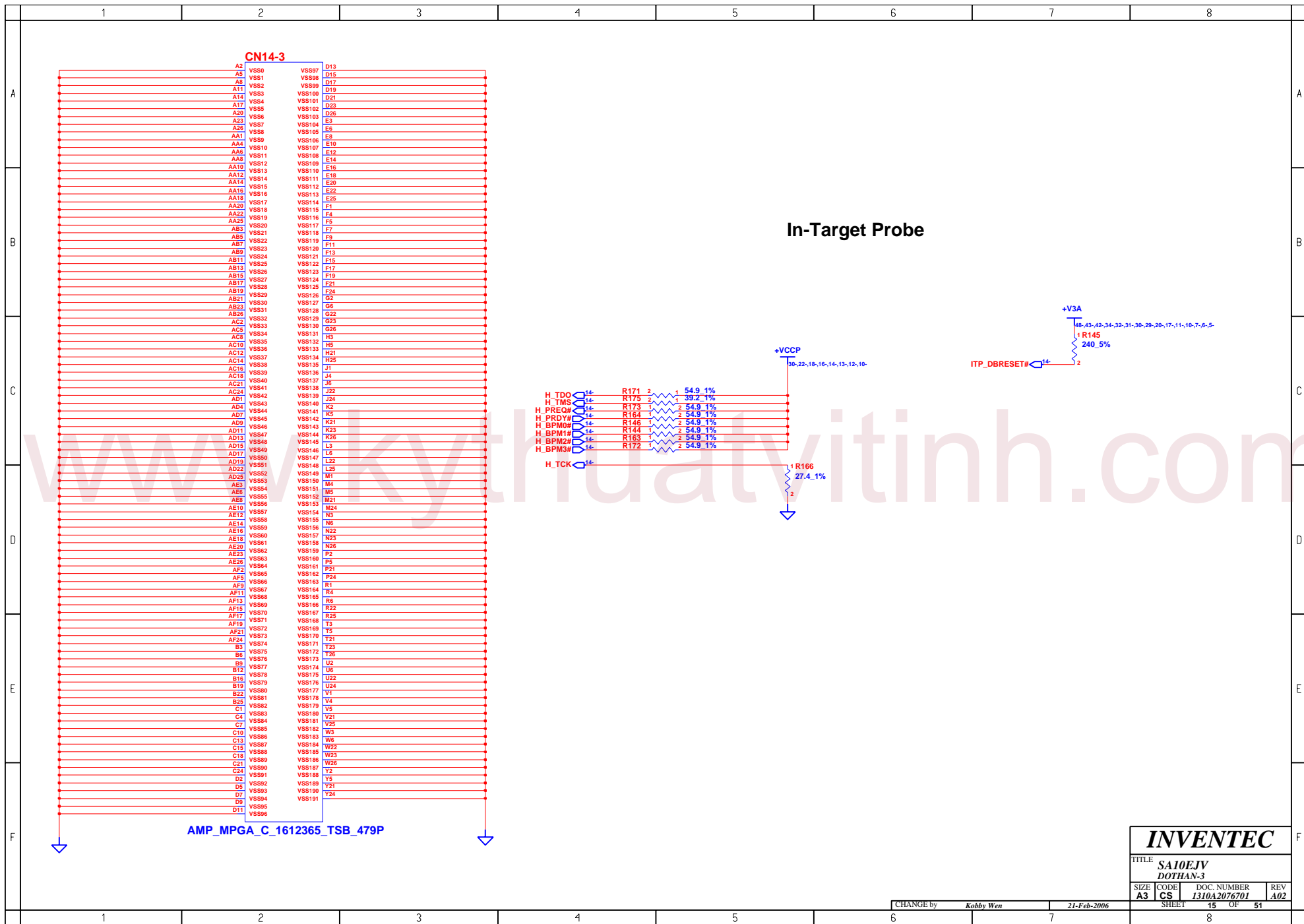

INVENTEC			
TITLE SA10EJV DOHAN-3			
SIZE A3	CODE CS	DOC. NUMBER 1310A2076701	REV A02
CHANGE by Kobby Wen		21-Feb-2006	
SHEET 15		OF 51	

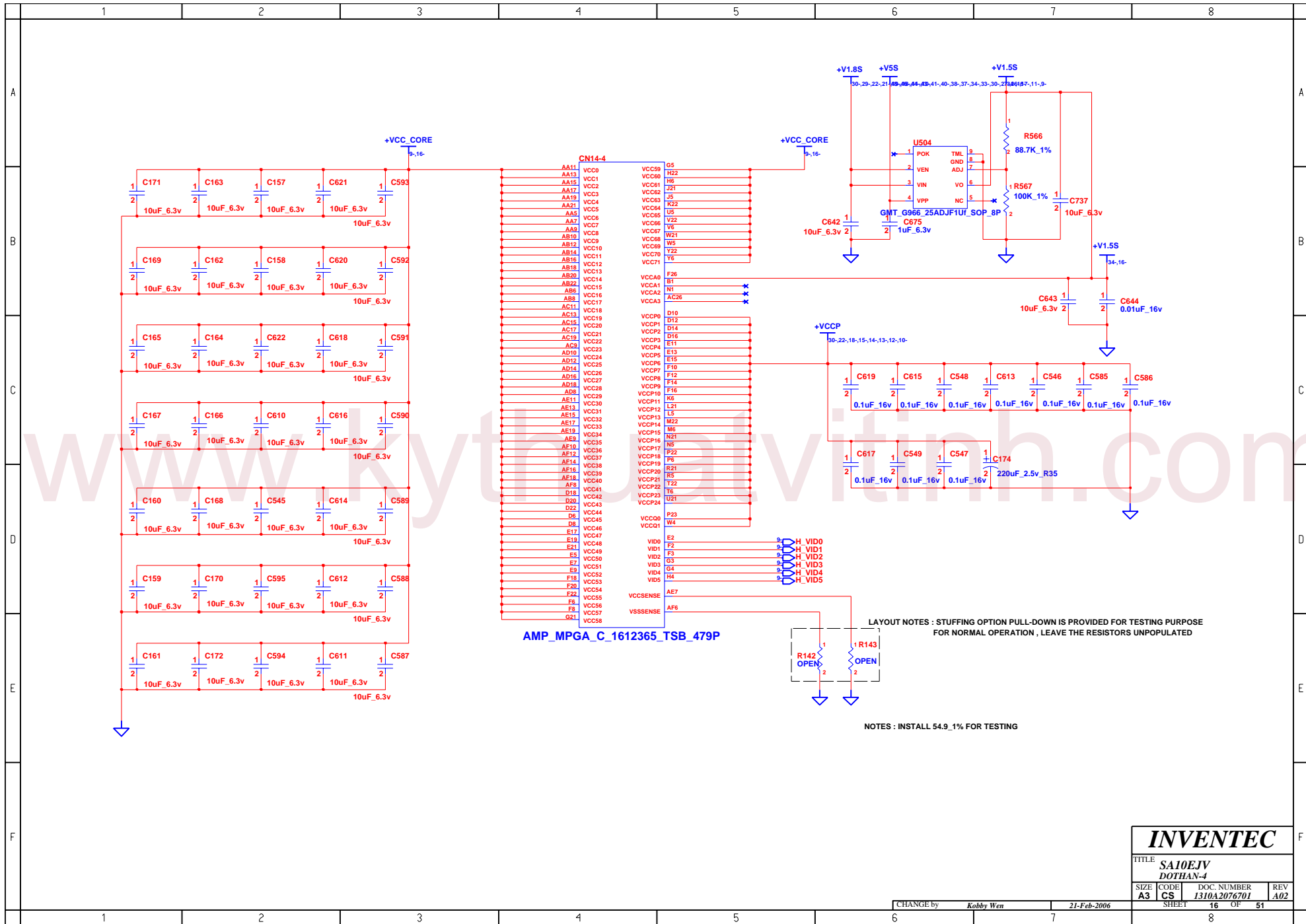

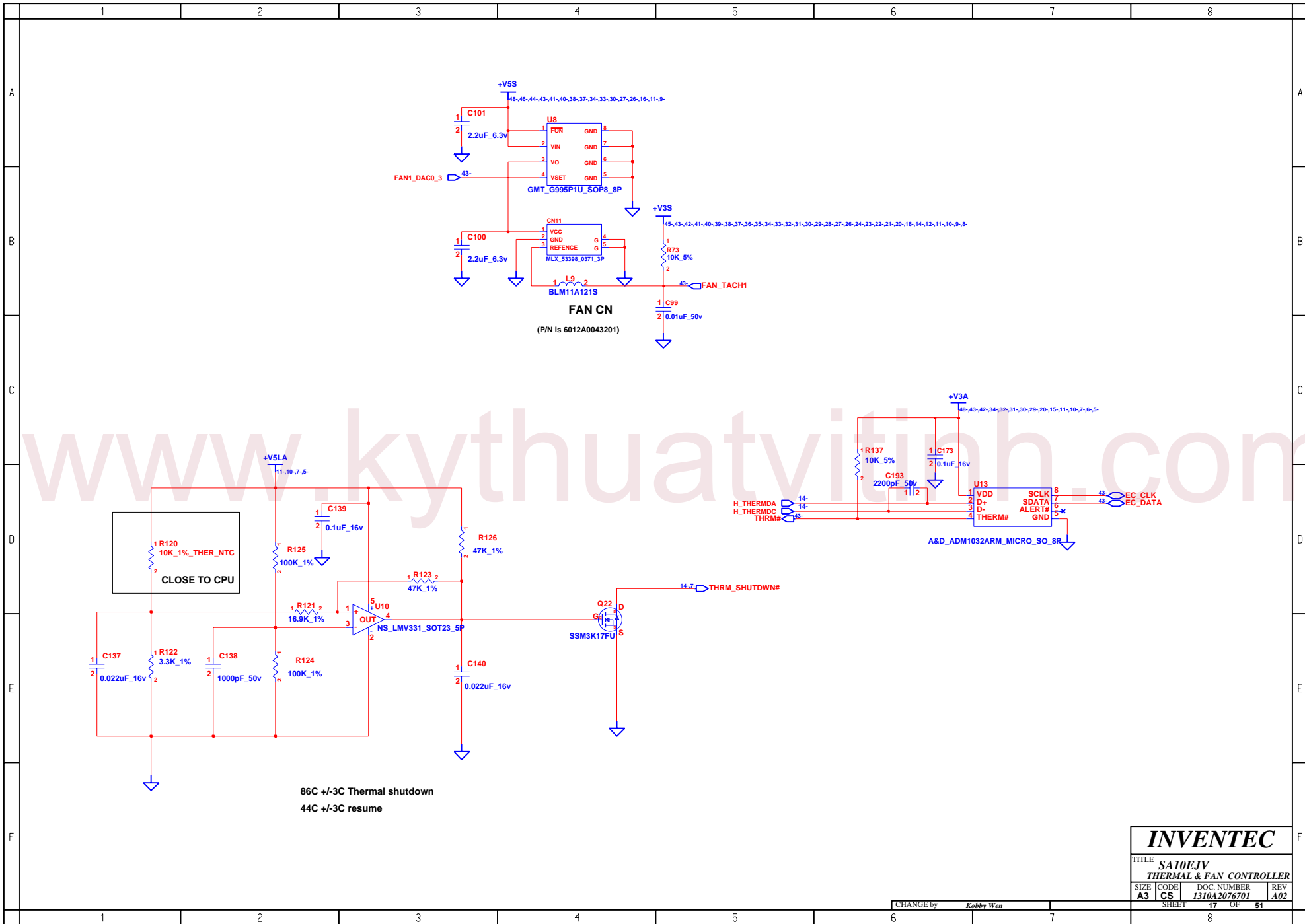

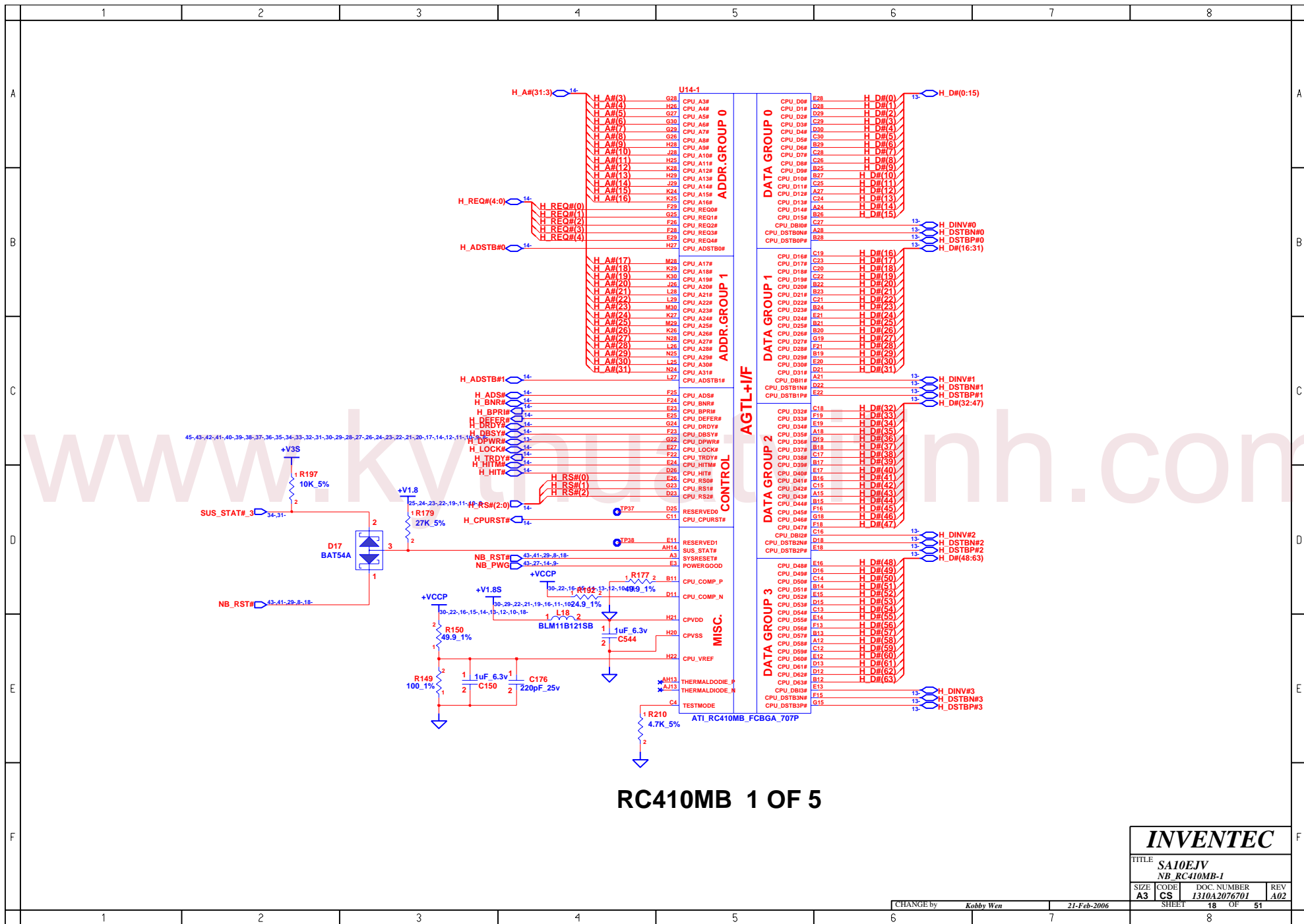

RC410MB 1 OF 5

INVENTEC

TITLE			
SA10EJV			
NB_RC410MB-1			
SIZE	CODE	DOC. NUMBER	REV
A3	CS	1310A2076701	A02
CHANGE by		SHEET	
Kobby Wen		18 OF 51	

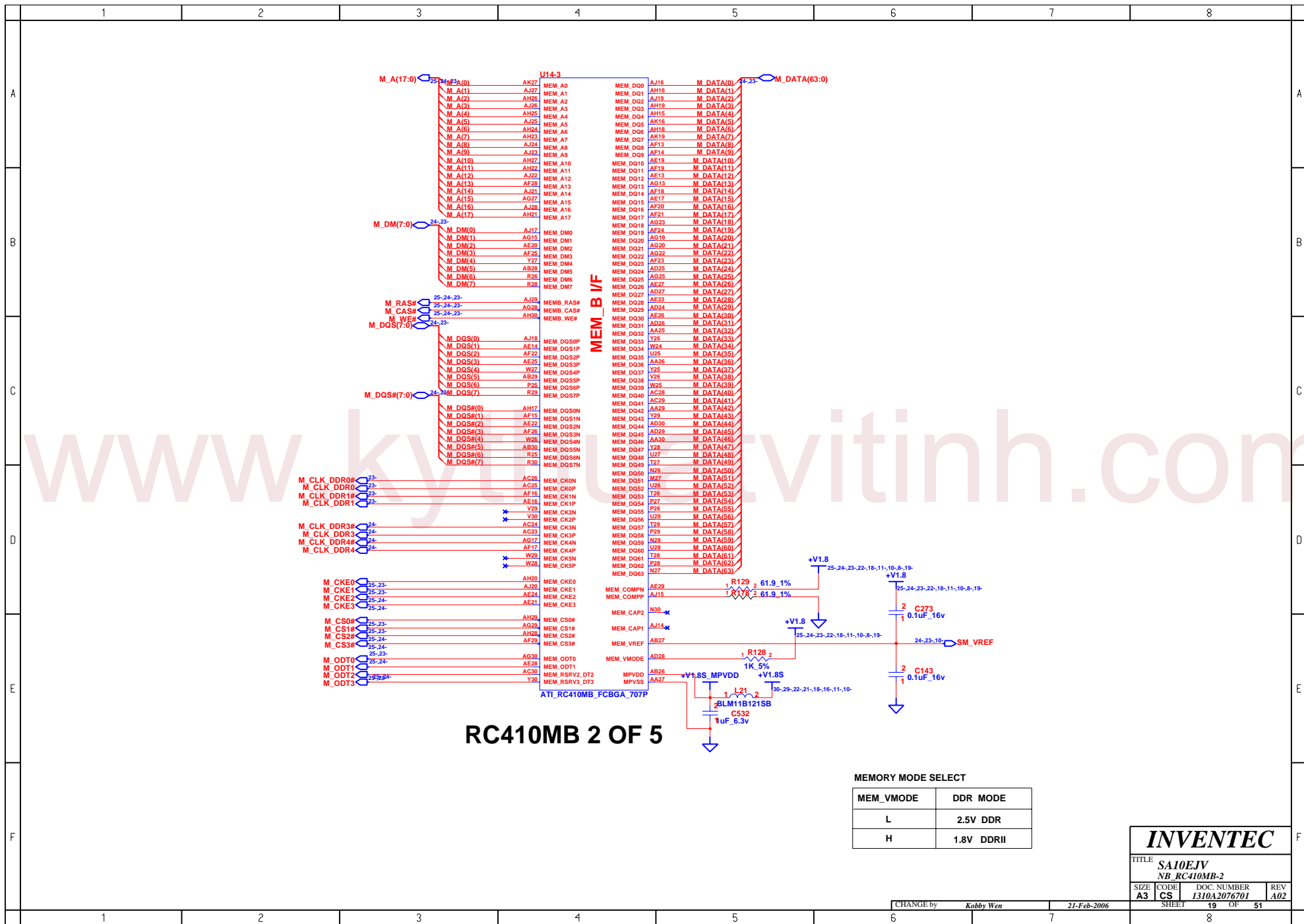

INVENTEC

TITLE: SA10EJV
NB RC410MB-2

SIZE A3	CODE CS	DOC. NUMBER 1310A2076701	REV A02
---------	---------	--------------------------	---------

CHANGE by: Kobby Wen 21-Feb-2006 SHEET 19 OF 51

BMREQ#	DACHSYNC	DACVSYNC	FSB
0	0	1	133M 7X0
0	0	0	100M 7X5

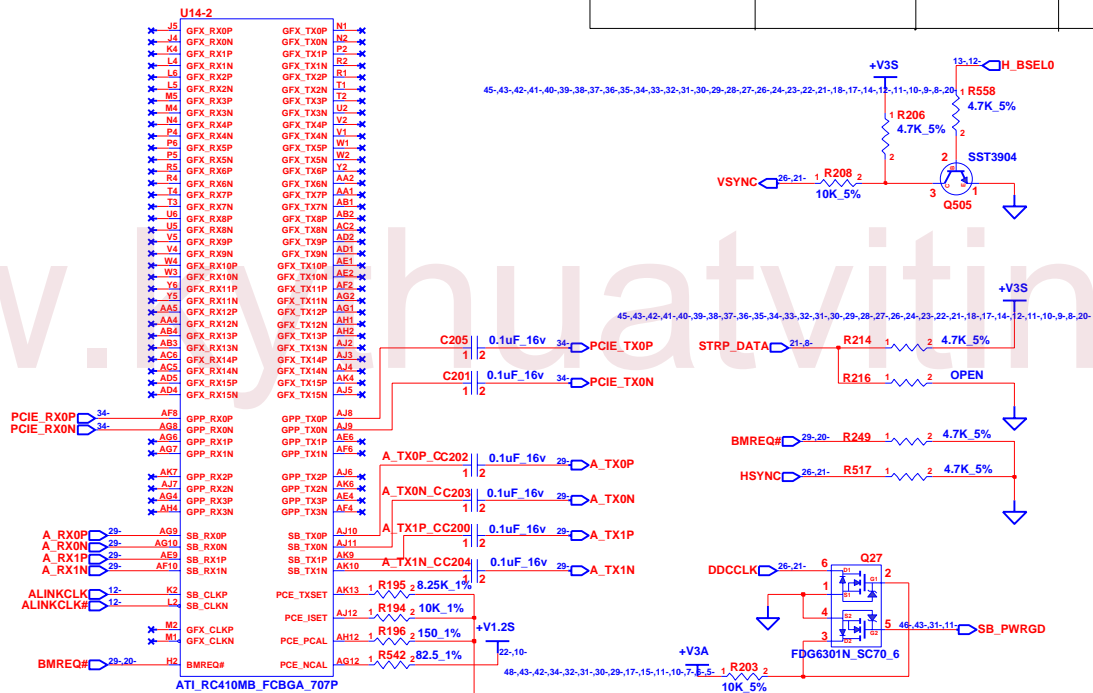

RC410MB 3 OF 5

0: MOBILE CPU
1: DESKTOP CPU

INVENTEC

TITLE			
SA10EJV			
NB RC410MB-3			
SIZE	CODE	DOC. NUMBER	REV
A3	CS	1310A2076701	A02

CHANGE by	Kobby Wen	21-Feb-2006	SHEET	20	OF	51
-----------	-----------	-------------	-------	----	----	----

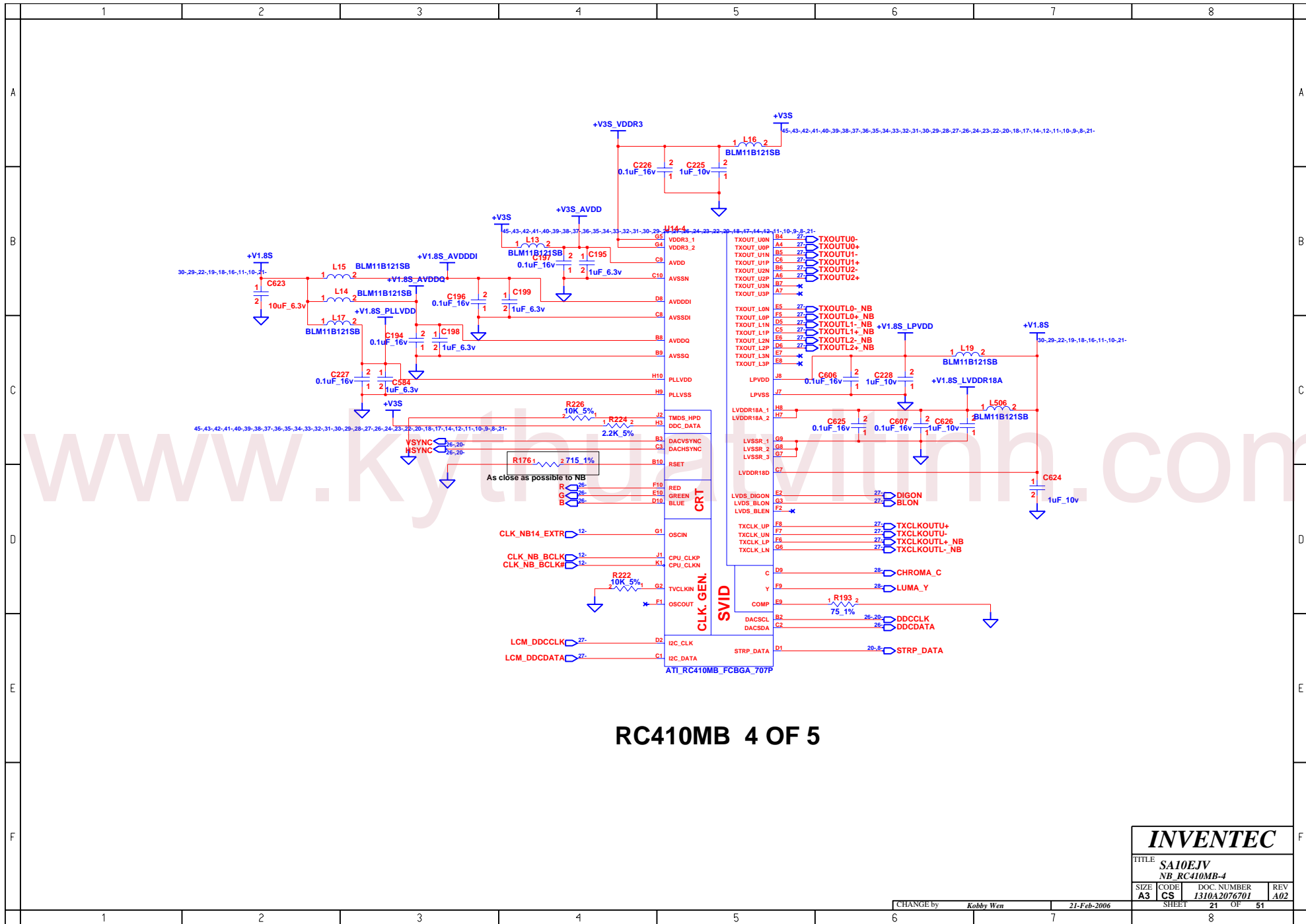

RC410MB 4 OF 5

INVENTEC			
TITLE SA10EJV NB_RC410MB-4			
SIZE A3	CODE CS	DOC NUMBER 1310A2076701	REV A02
CHANGE by Kobby Wen		21-Feb-2006	
SHEET 21		OF 51	

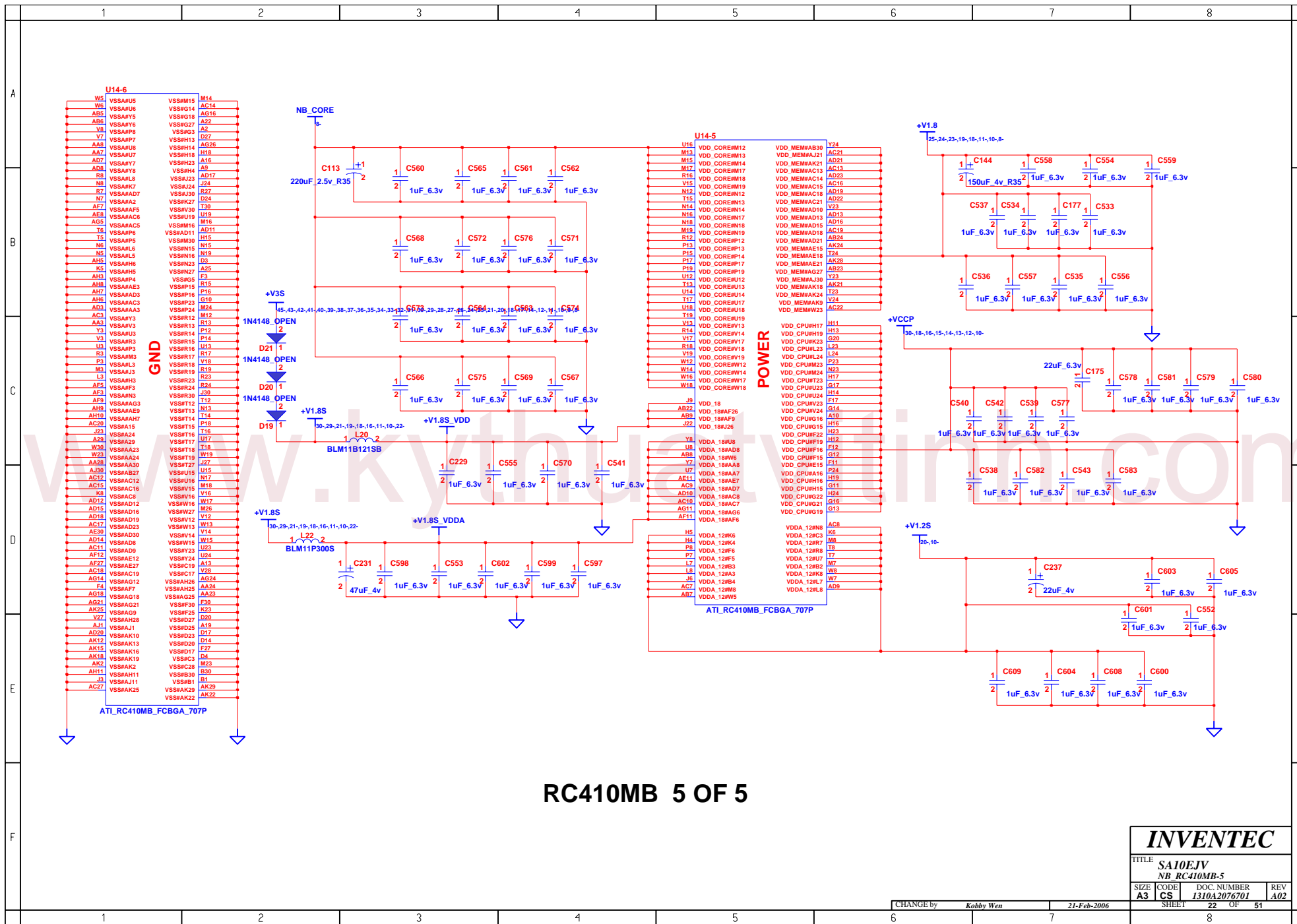

RC410MB 5 OF 5

INVENTEC			
TITLE SA10EJV			
NB_RC410MB-5			
SIZE A3	CODE CS	DOC. NUMBER 1310A2076701	REV A02
CHANGE by Kobby Wen		21-Feb-2006	
SHEET 22		OF 51	

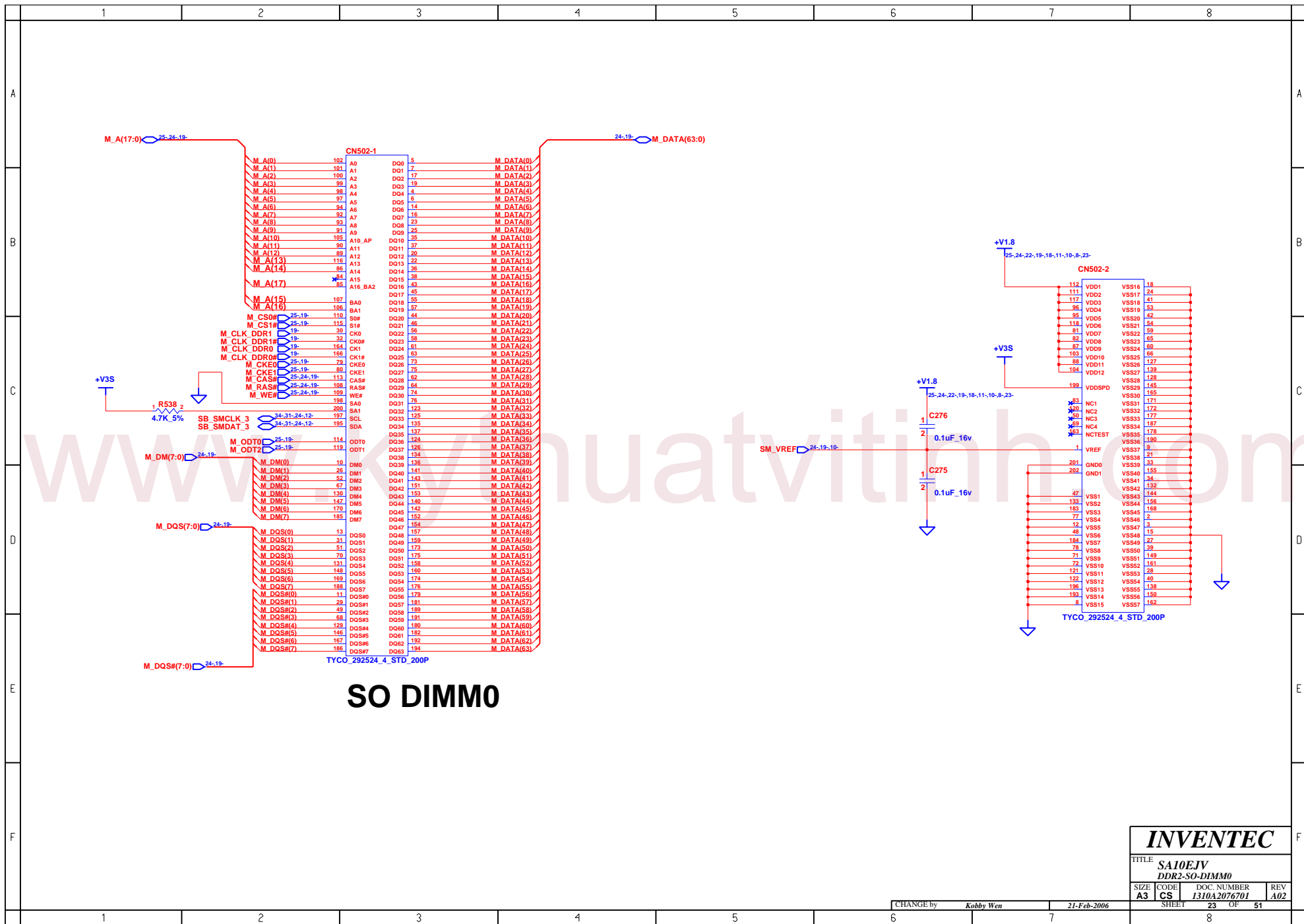

INVENTEC			
TITLE SAI0EJV			
DDR2-SO-DIMM0			
SIZE A3	CODE CS	DOC. NUMBER 1310A2076701	REV A02
CHANGE by Kobby Wen		21-Feb-2006	
SHEET 23		OF 51	

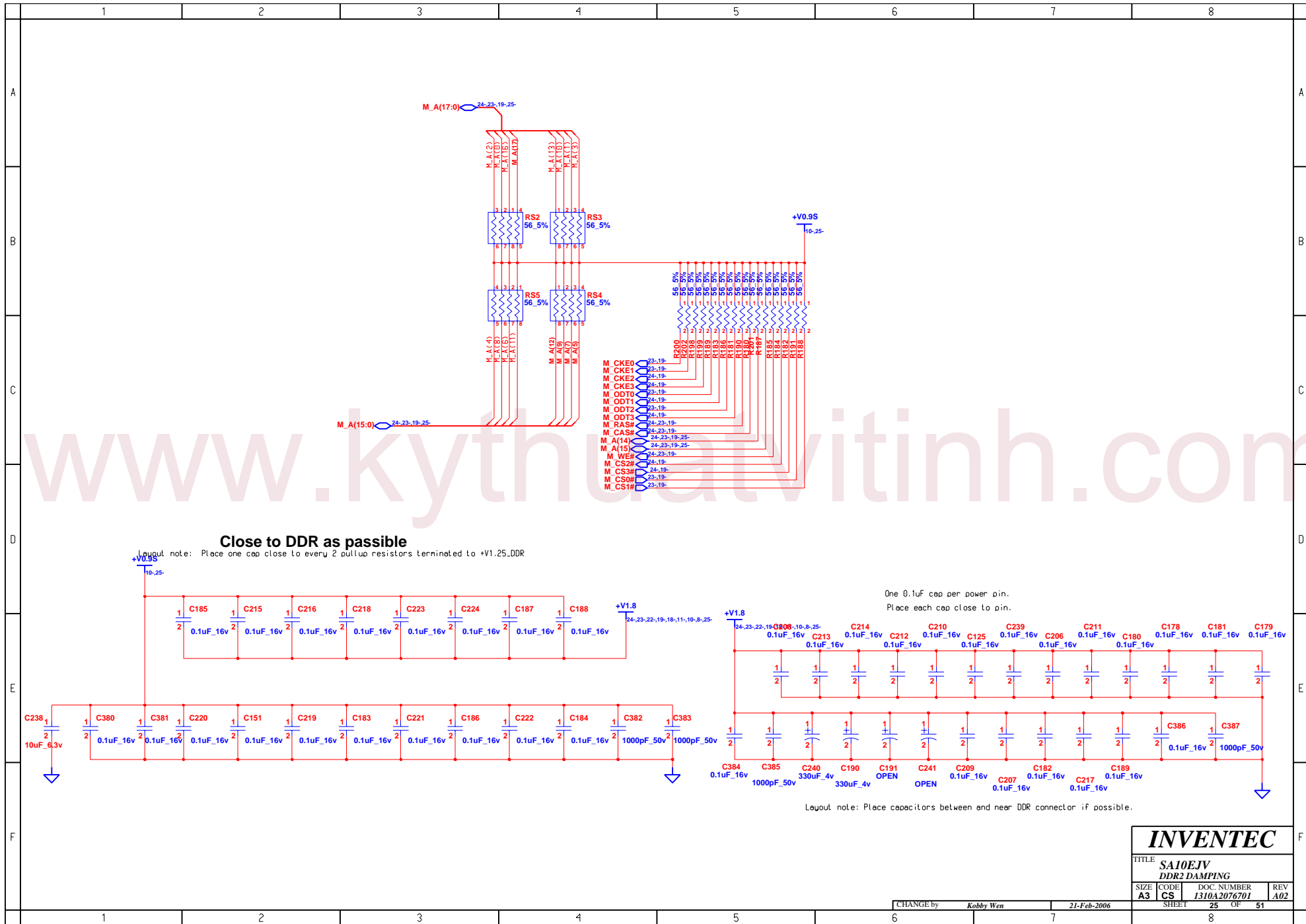

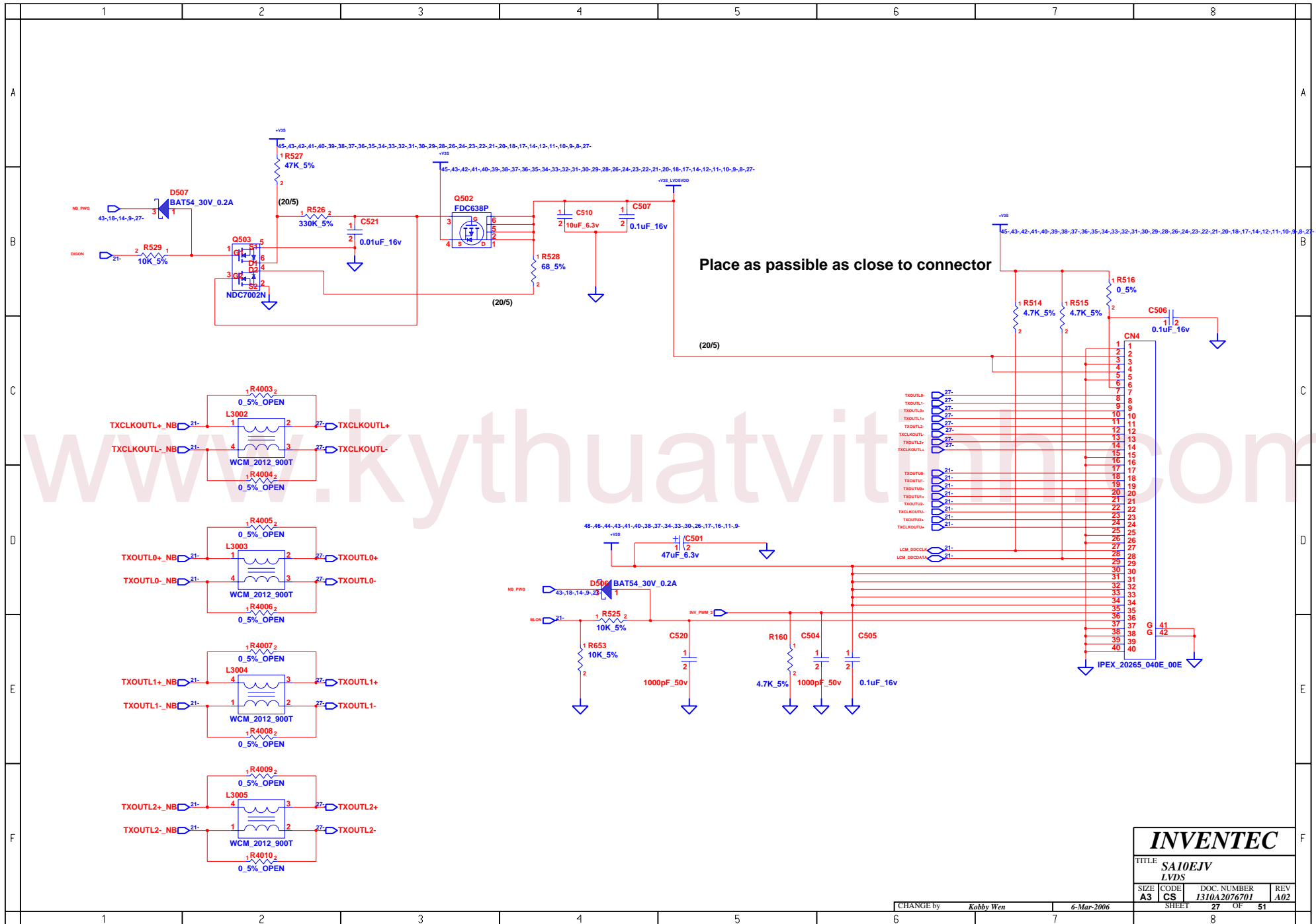

INVENTEC			
TITLE SA10EJV			
LDVS			
SIZE A3	CODE CS	DOC. NUMBER 1310A2076701	REV A02
CHANGE by Kobby Wen		6-Mar-2006	SHEET 27 OF 51

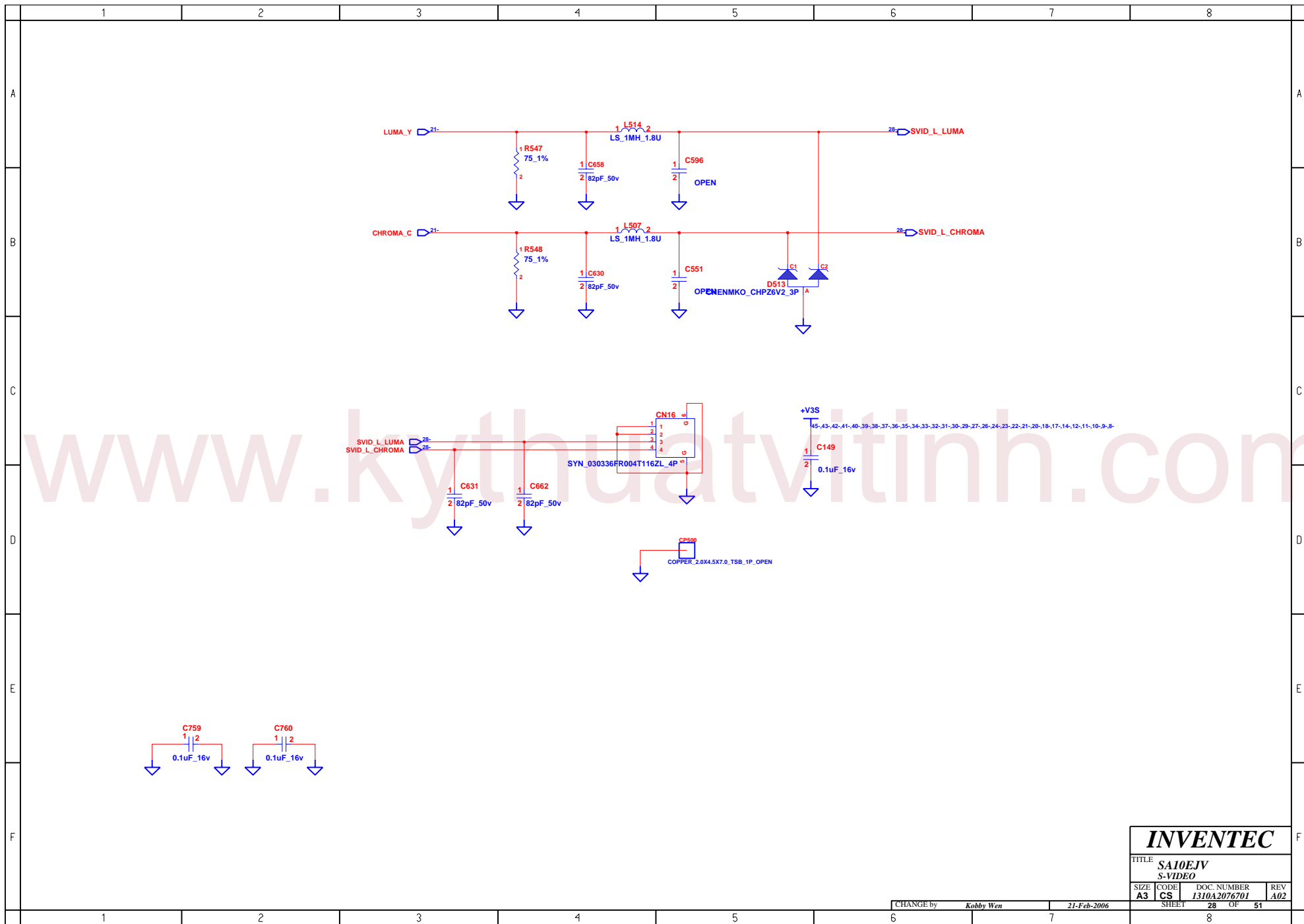

INVENTEC

TITLE **SA10EJV**
S-VIDEO

SIZE	CODE	DOC. NUMBER	REV
A3	CS	1310A2076701	A02

CHANGE by *Kobby Wen* 21-Feb-2006
 SHEET 28 OF 51

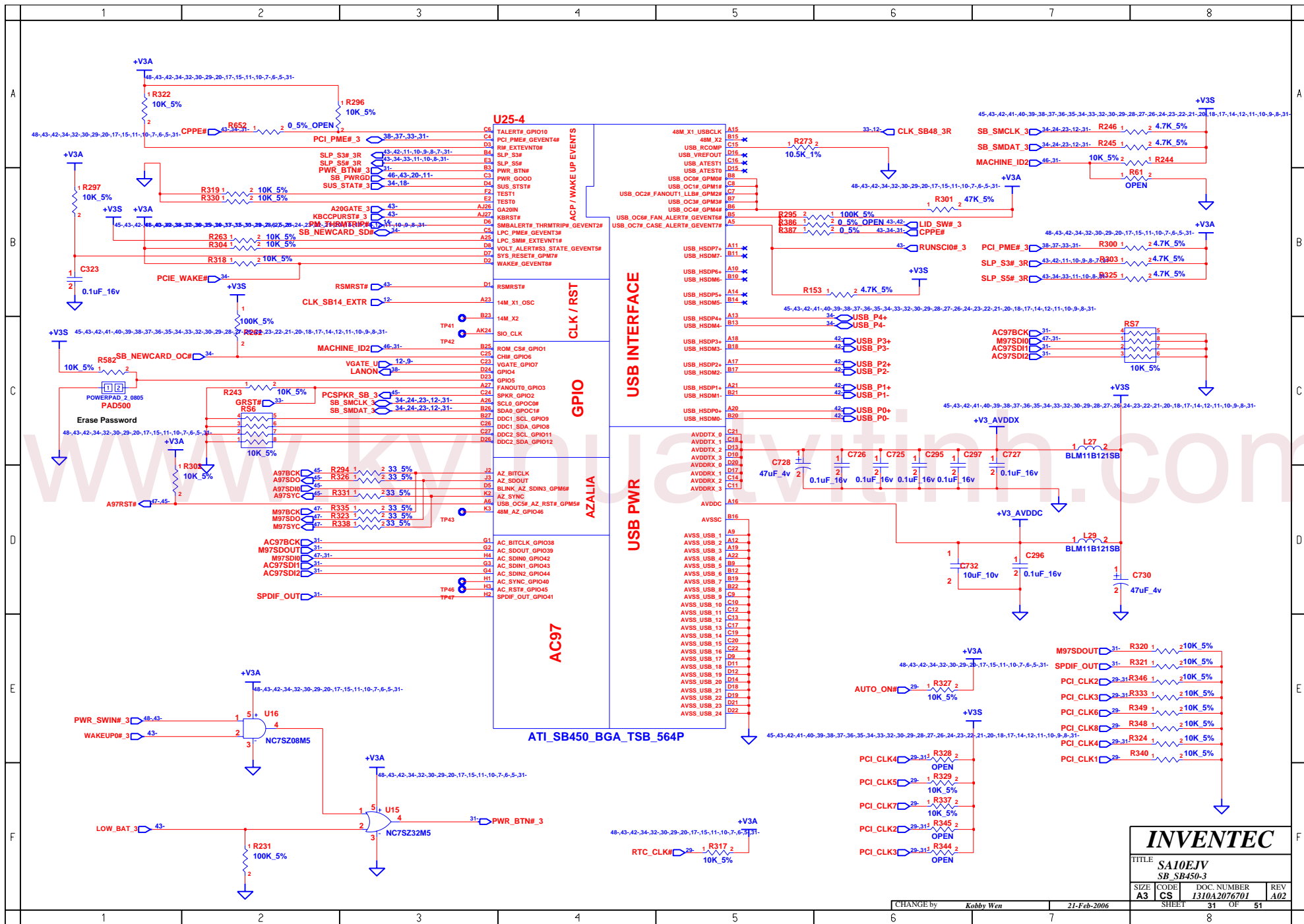

INVENTEC

TITLE: SA10EJV
SB_SB450-3

SIZE	CODE	DOC. NUMBER	REV
A3	CS	1310A2076701	A02

SHEET 31 OF 51

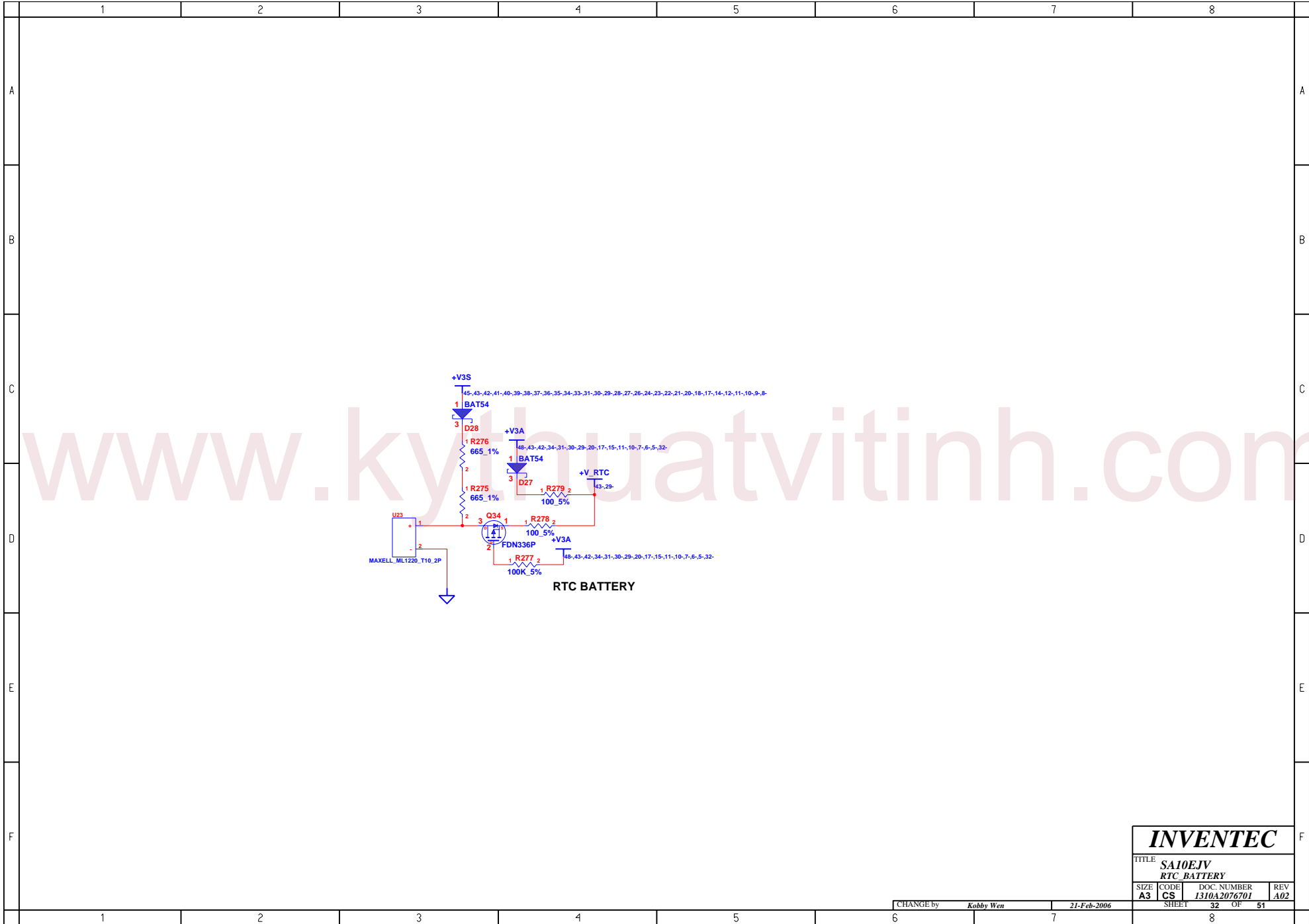

INVENTEC

TITLE			
SA10EJV			
RTC BATTERY			
SIZE	CODE	DOC. NUMBER	REV
A3	CS	1310A2076701	A02

CHANGE by *Kobby Wen* 21-Feb-2006

SHEET 32 OF 51

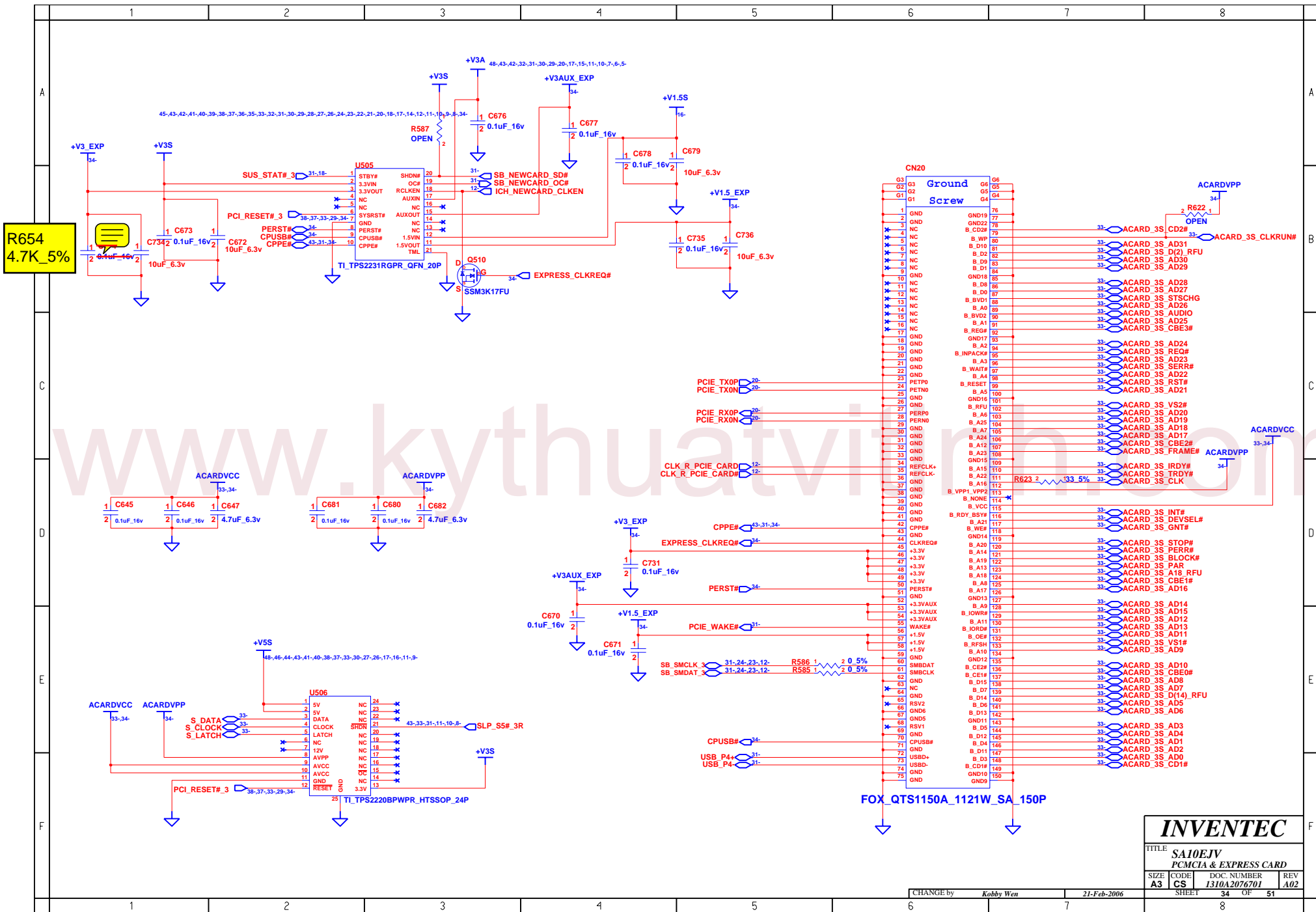

INVENTEC			
TITLE: SA10EJV PCMCIA & EXPRESS CARD			
SIZE	CODE	DOC. NUMBER	REV
A3	CS	I310A2076701	A02
CHANGE by		21-Feb-2006	
Kobby Wen		SHEET 34 OF 51	

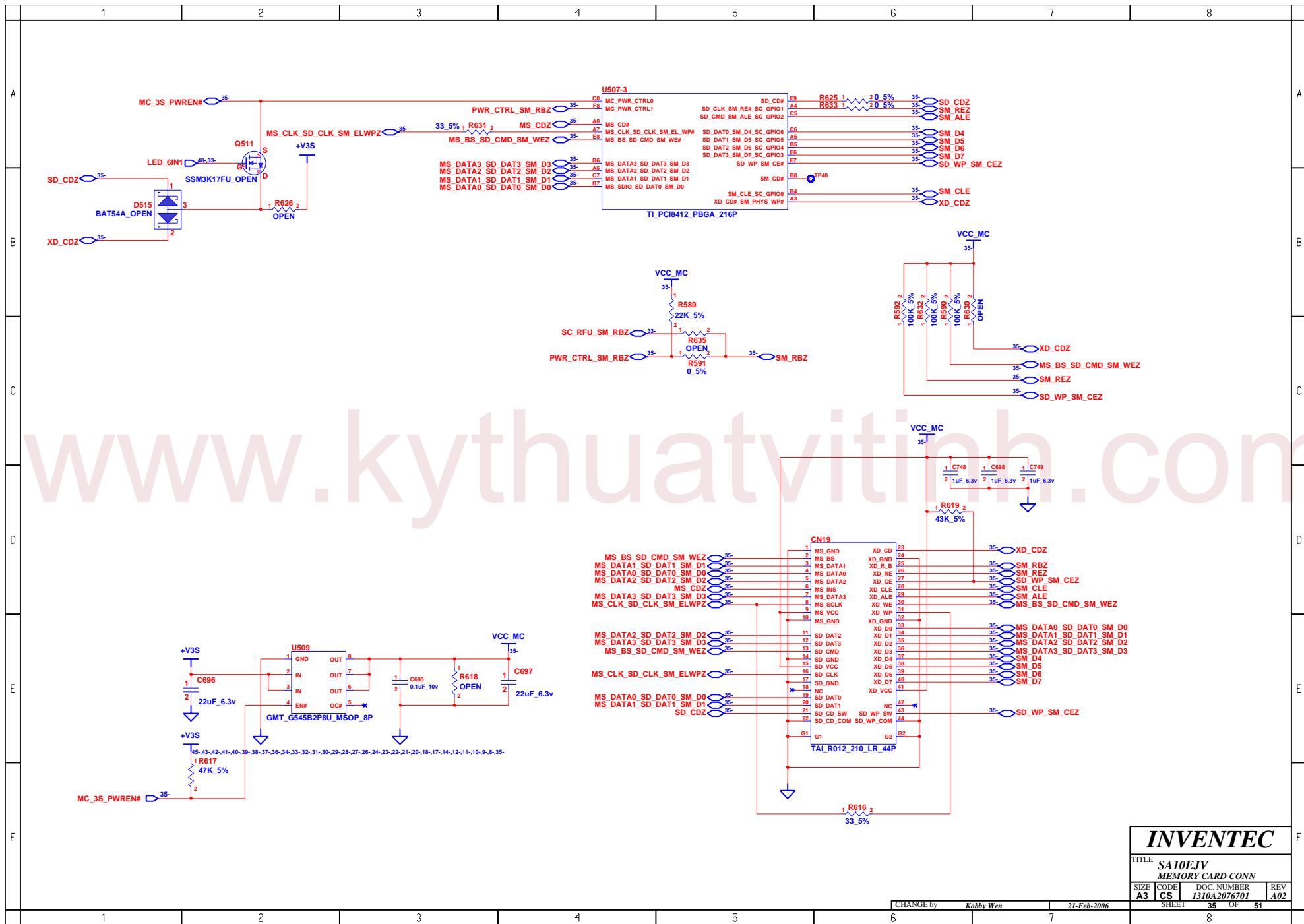

INVENTEC			
TITLE: SA10EJV MEMORY CARD CONN			
SIZE	CODE	DOC. NUMBER	REV
A3	CS	1310A2076701	A02
CHANGE by		21-Feb-2006	
Kobby Wen		SHEET 35 OF 51	

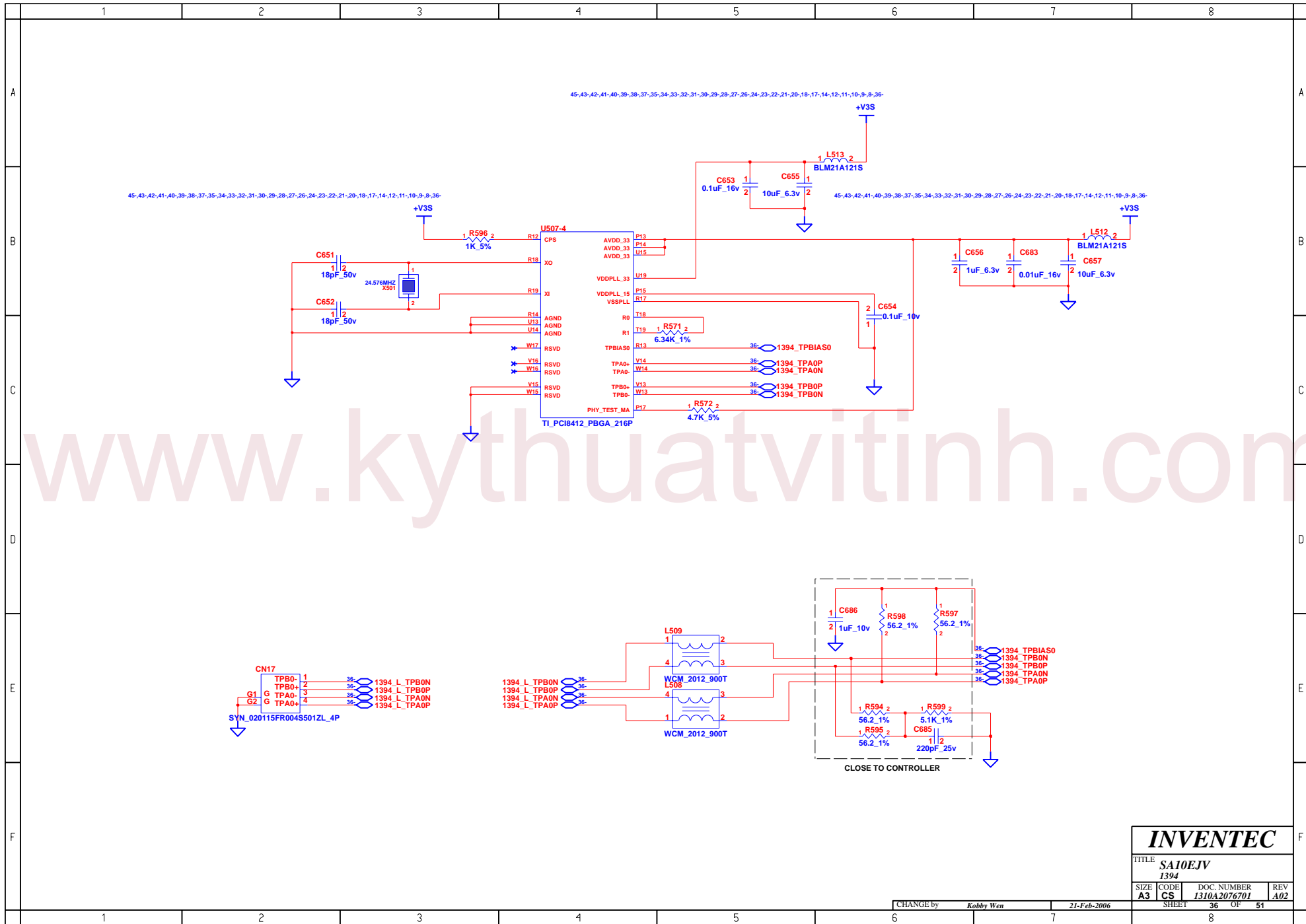

www.kythuativitinh.com

INVENTEC

TITLE
SA10EJV
1394

SIZE	CODE	DOC. NUMBER	REV
A3	CS	1310A2076701	A02

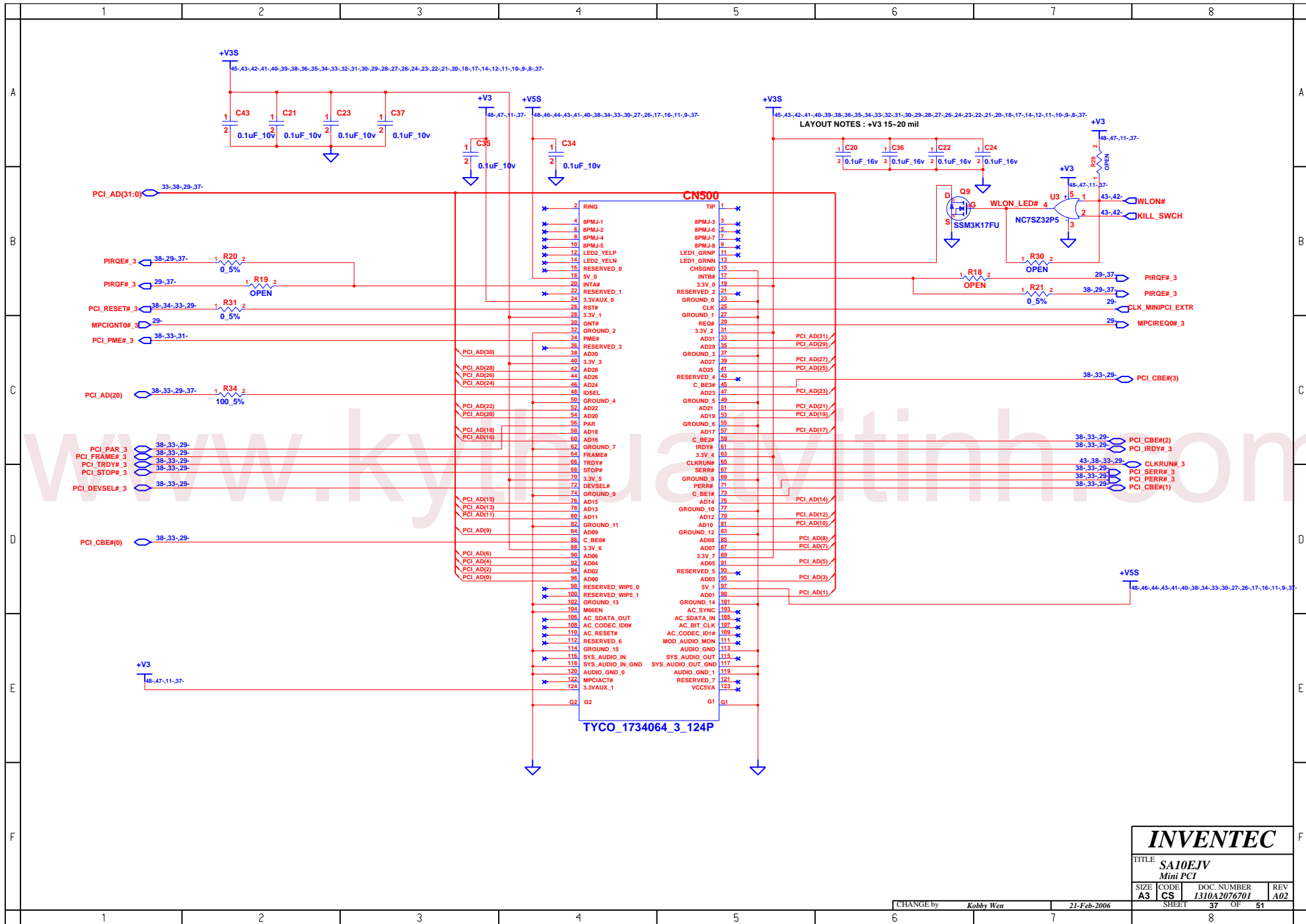

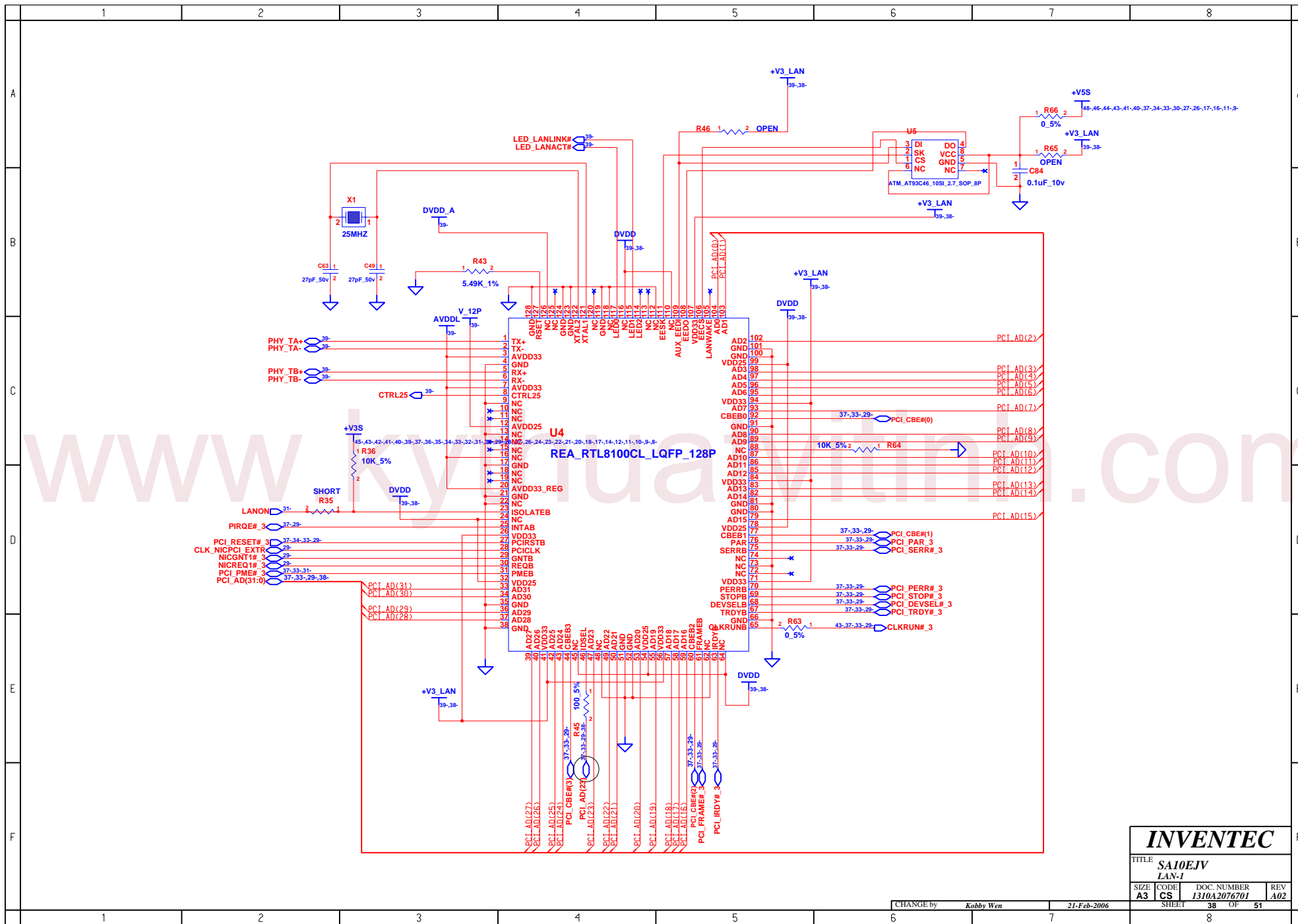

INVENTEC

TITLE
SA10EJV
LAN-1

SIZE	CODE	DOC. NUMBER	REV
A3	CS	1310A2076701	A02

CHANGE by *Kobby Wen* 21-Feb-2006

SHEET 38 OF 51

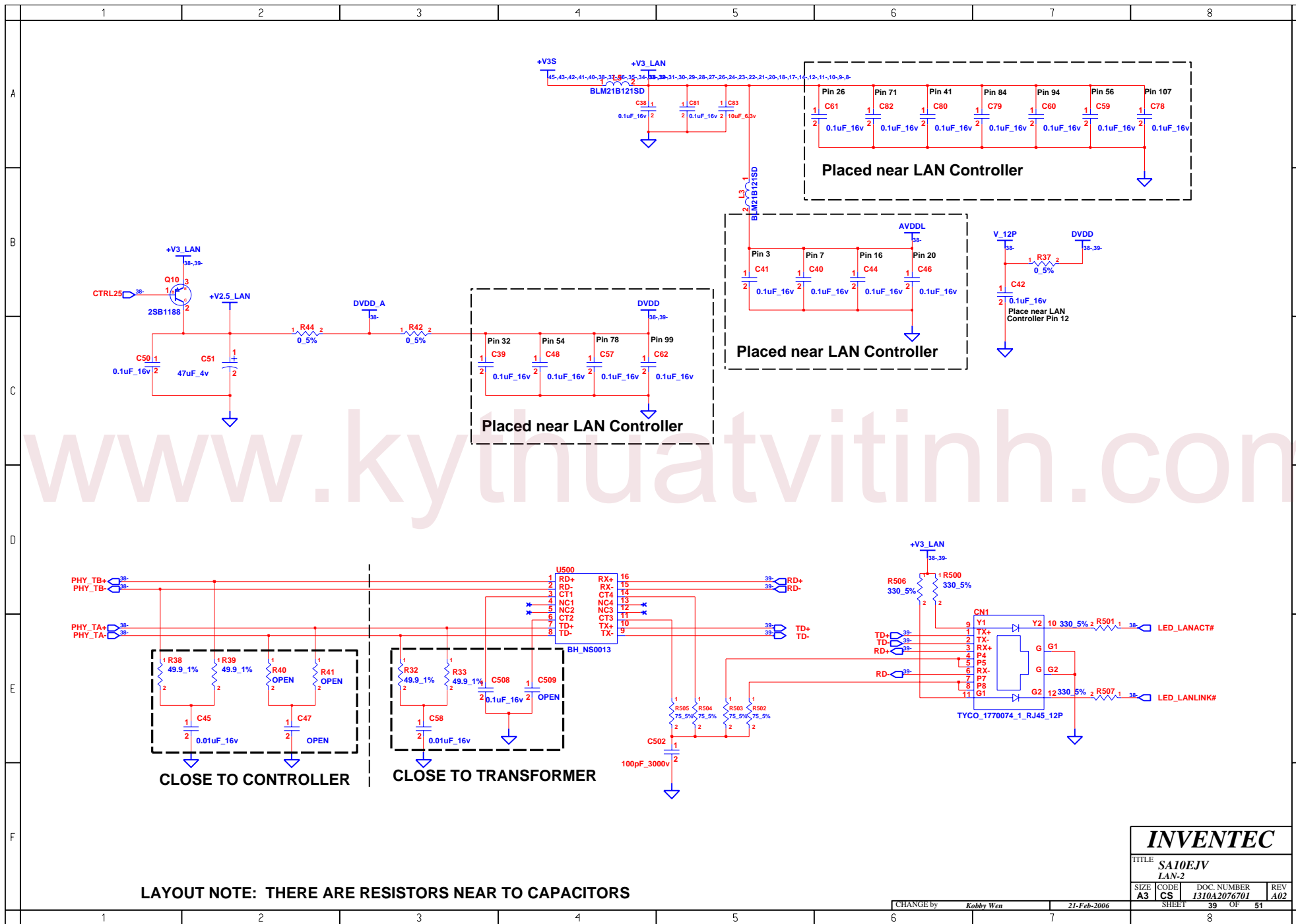

INVENTEC			
TITLE SA10EJV LAN-2			
SIZE A3	CODE CS	DOC. NUMBER 1310A2076701	REV A02
CHANGE by <i>Kobby Wen</i>		21-Feb-2006	
SHEET 39		OF 51	

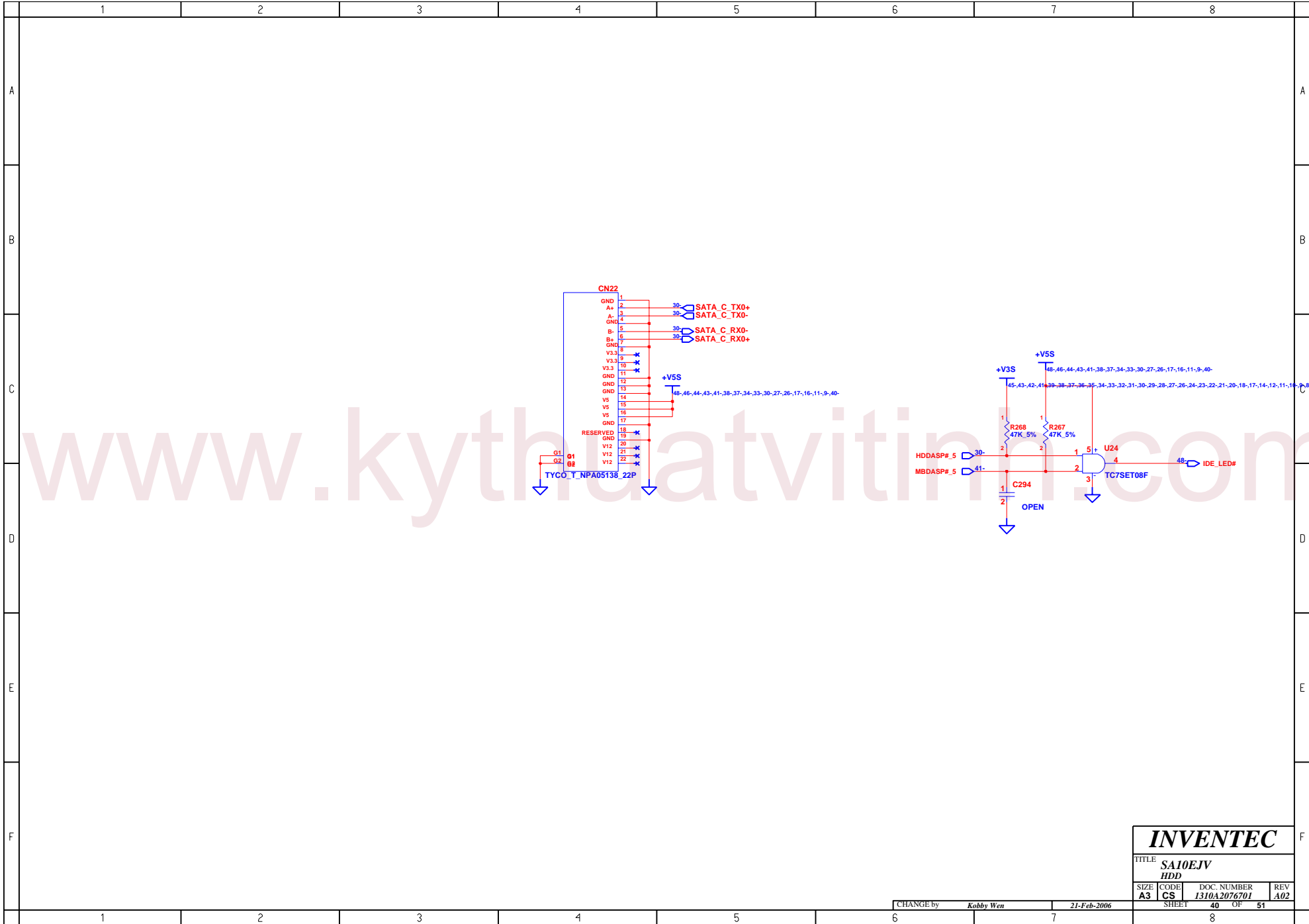

INVENTEC

TITLE			
SA10EJV			
HDD			
SIZE	CODE	DOC. NUMBER	REV
A3	CS	1310A2076701	A02

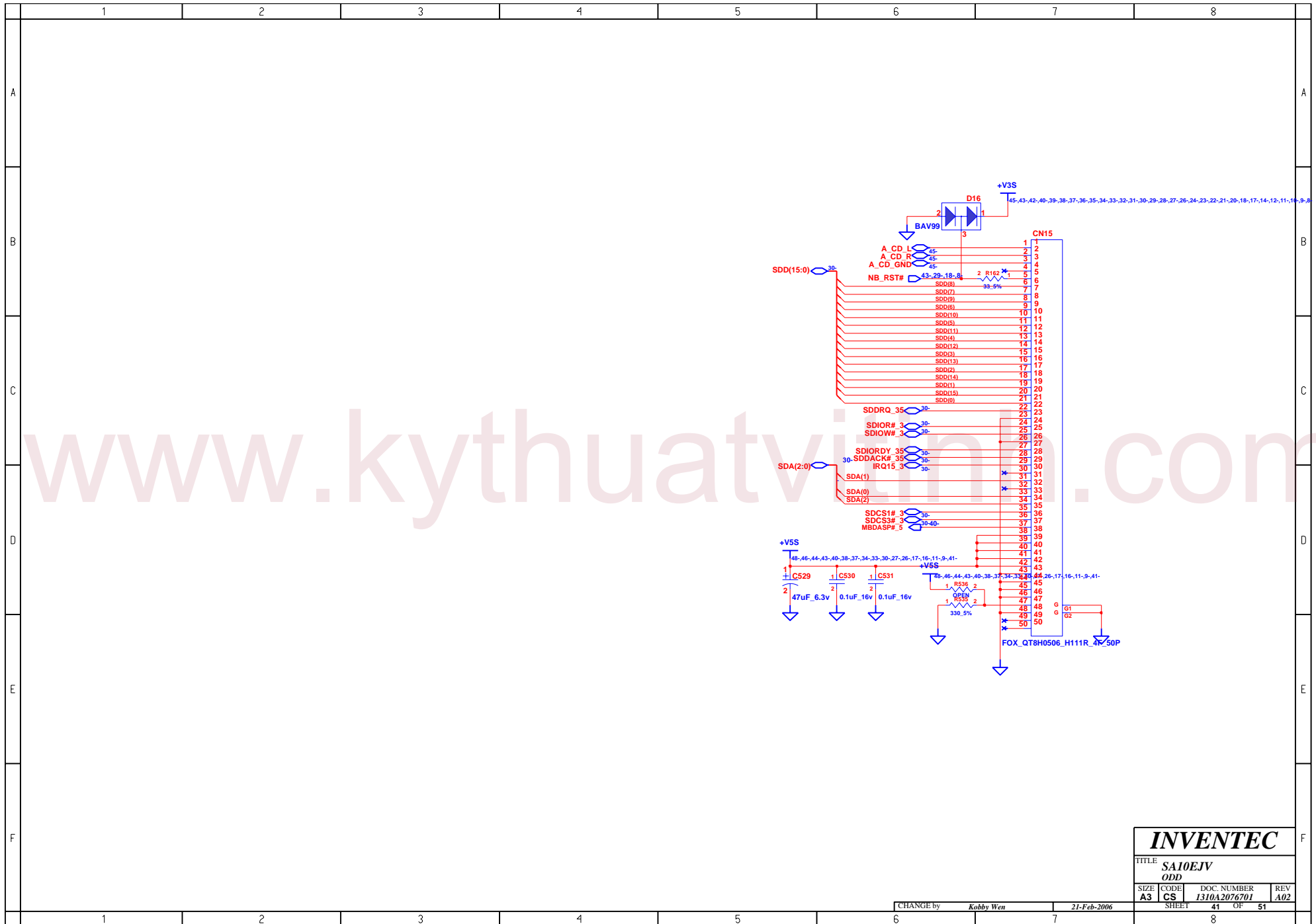

INVENTEC			
TITLE SA10EJV			
ODD			
SIZE A3	CODE CS	DOC. NUMBER 1310A2076701	REV A02

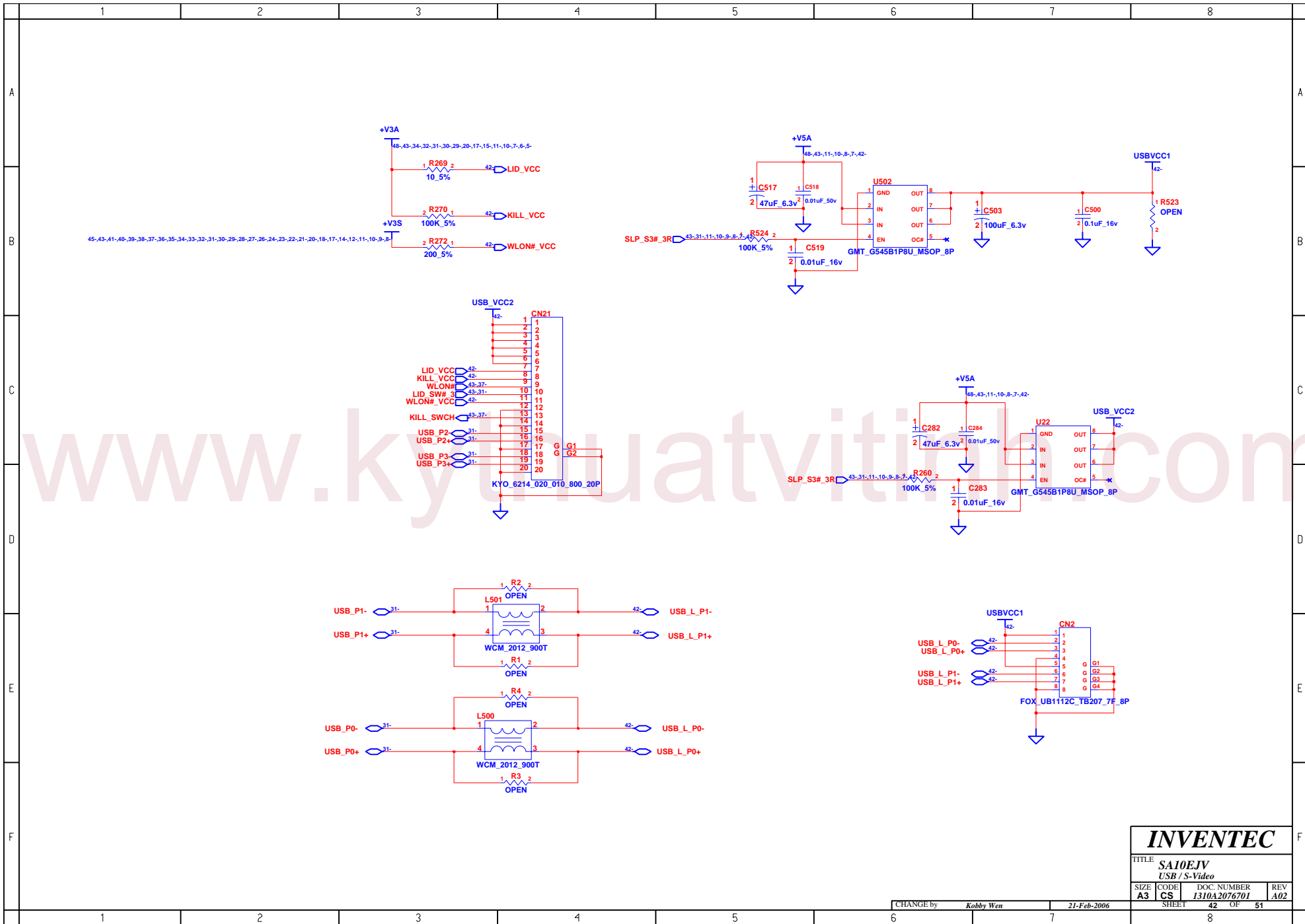

INVENTEC

TITLE
SA10EJV
USB / S-Video

SIZE A3	CODE CS	DOC. NUMBER I310A2076701	REV A02
------------	------------	-----------------------------	------------

CHANGE by Kobby Wen	21-Feb-2006	SHEET 42	OF 51
------------------------	-------------	-------------	----------

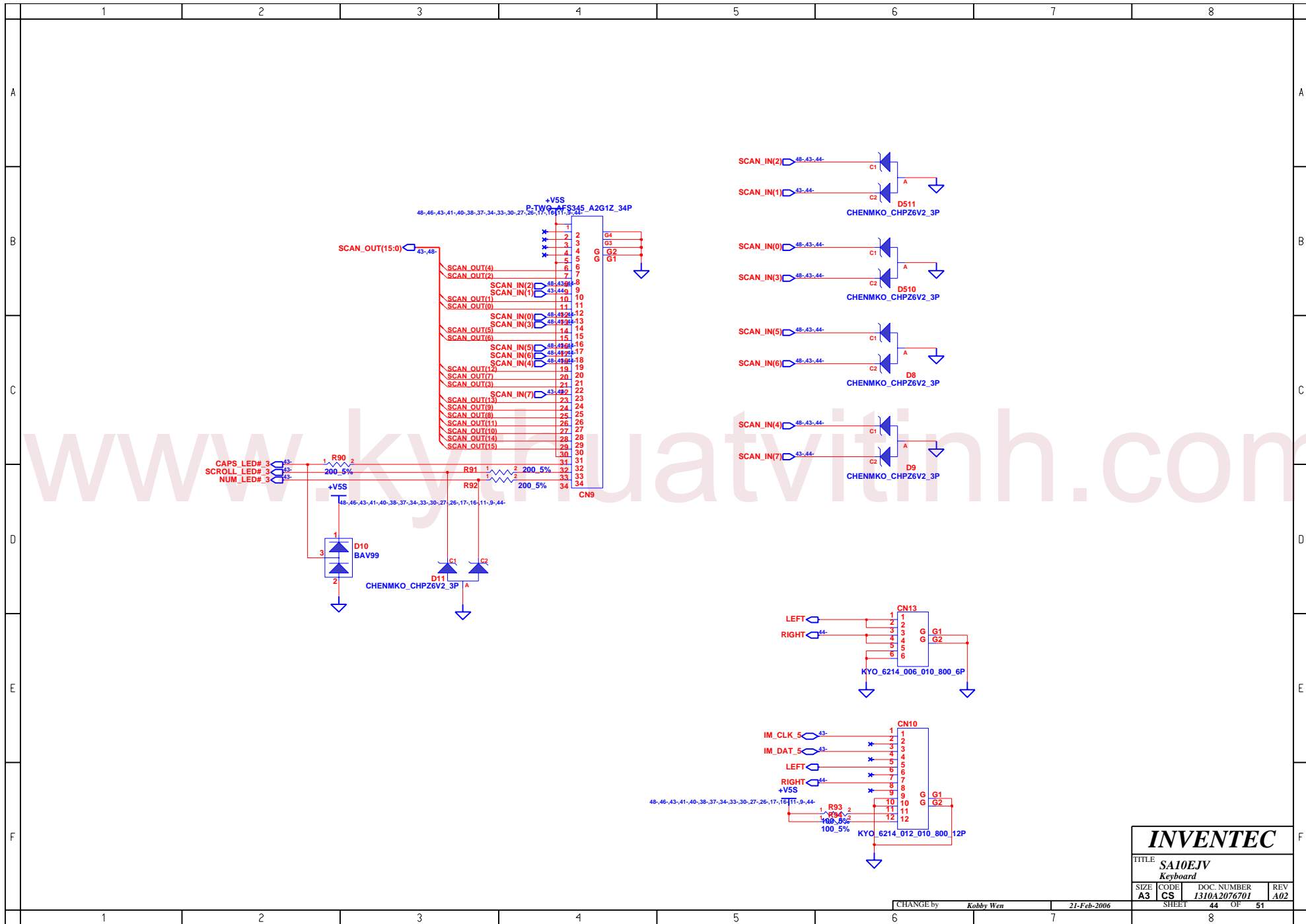

INVENTEC			
TITLE SA10EJV Keyboard			
SIZE A3	CODE CS	DOC. NUMBER 1310A2076701	REV A02
CHANGE by <i>Kobby Wen</i>		21-Feb-2006	
SHEET 44		OF 51	

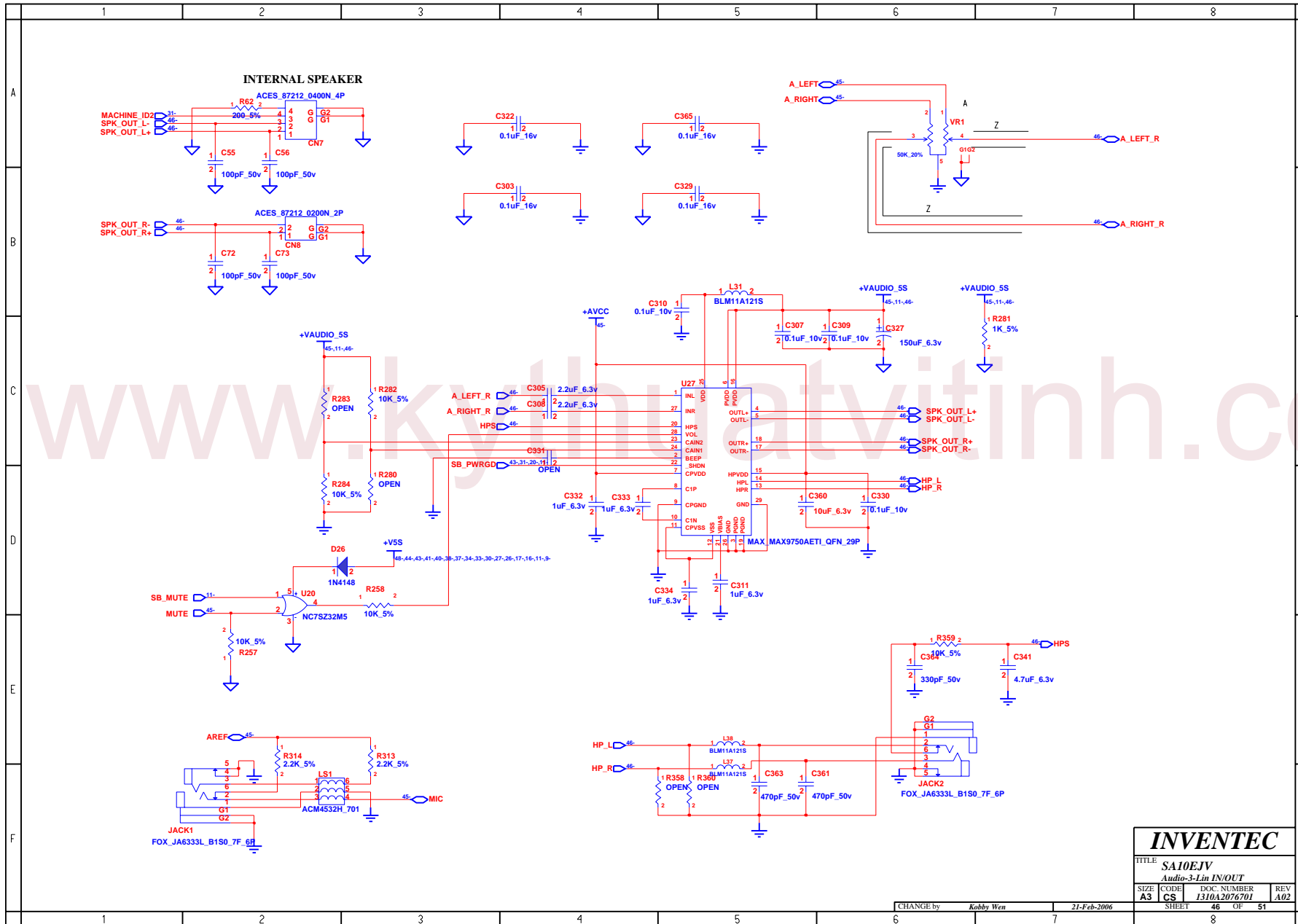

INVENTEC			
TITLE SA10EJV			
Audio-3-Lin IN/OUT			
SIZE	CODE	DOC. NUMBER	REV
A3	CS	1310A2076701	A02

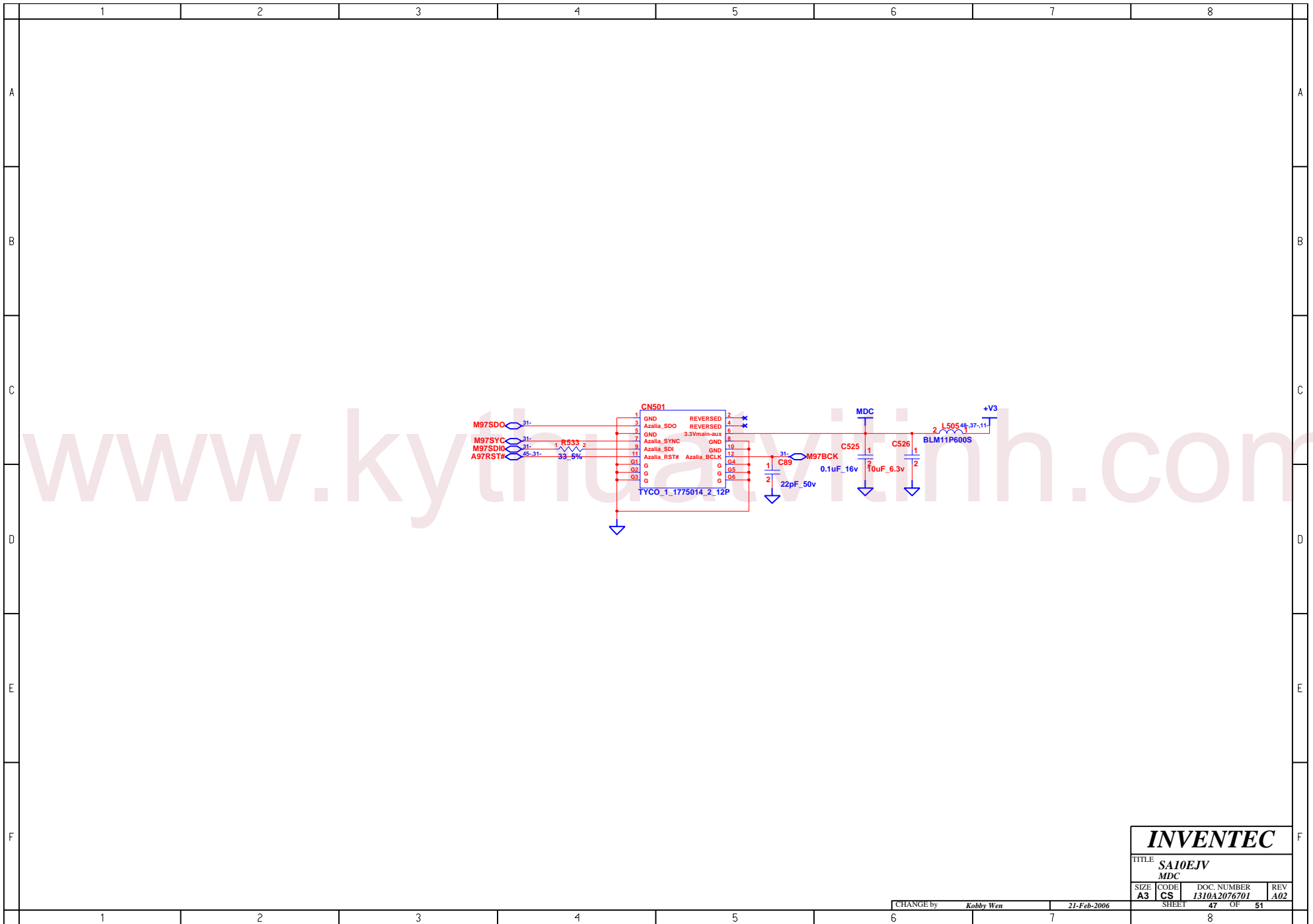

INVENTEC

TITLE **SA10EJV**
MDC

SIZE A3	CODE CS	DOC. NUMBER 1310A2076701	REV A02
----------------	----------------	---------------------------------	----------------

CHANGE by *Kobby Wen* 21-Feb-2006 SHEET 47 OF 51

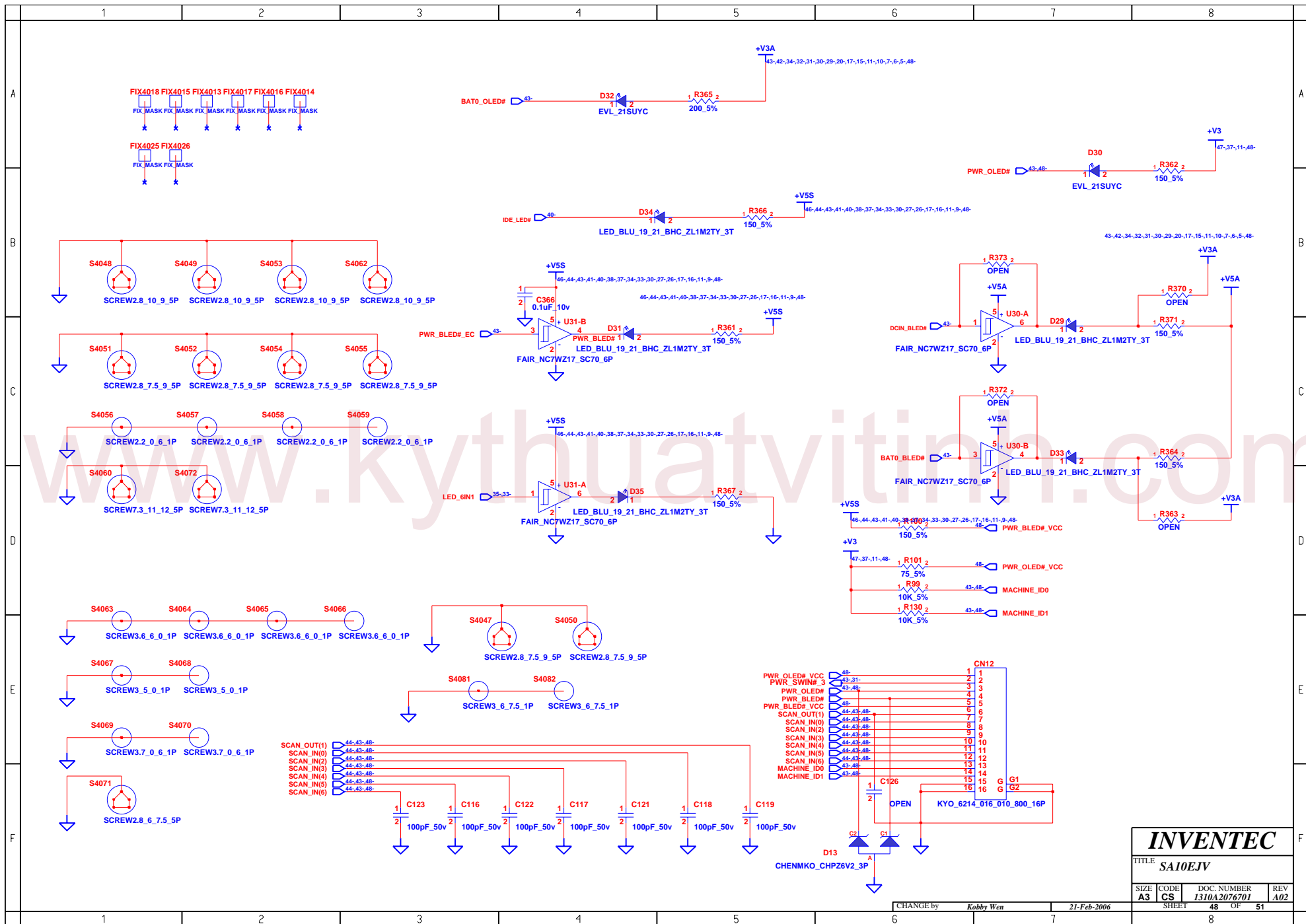

INVENTEC			
TITLE SA10EJV			
SIZE A3	CODE CS	DOC. NUMBER 1310A2076701	REV A02
CHANGE by <i>Kobby Wen</i>		21-Feb-2006	
SHEET 48		OF 51	

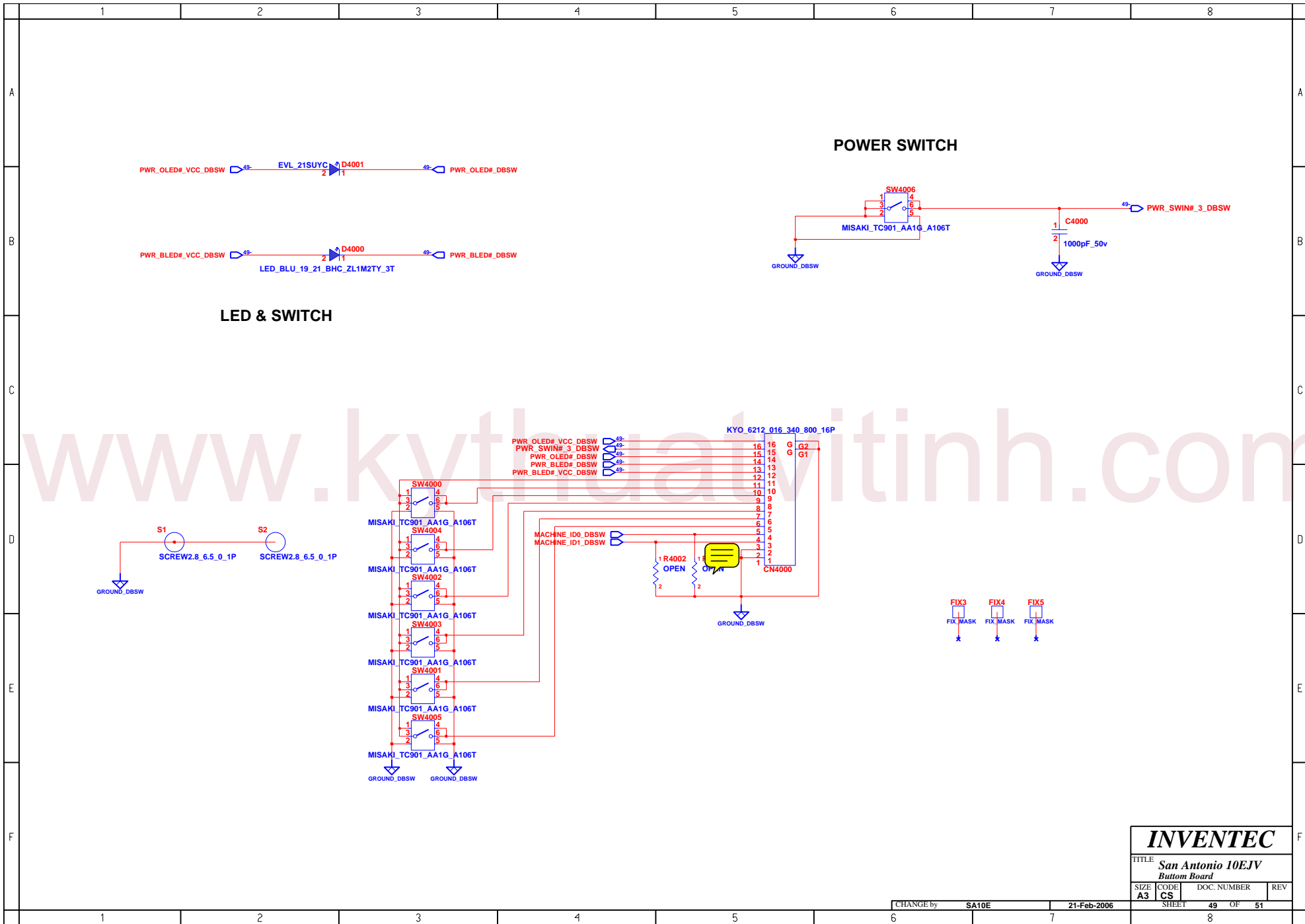

INVENTEC

TITLE **San Antonio 10EJV**
Bottom Board

SIZE **A3** CODE **CS** DOC. NUMBER REV

KILL SWITCH

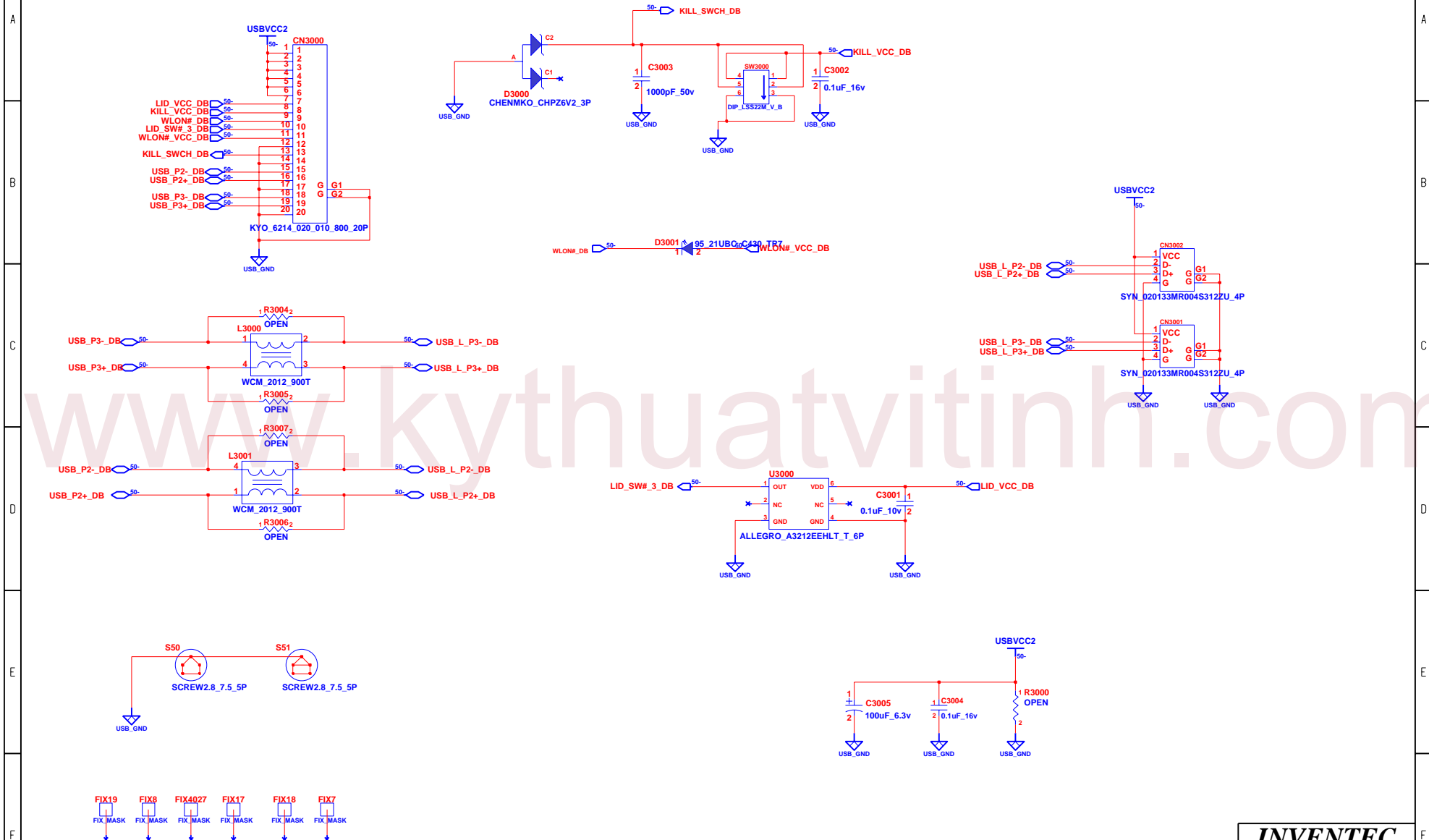

INVENTEC

TITLE			SA10EJV		
CODE			USB/1394/SVIDEO Board		
SIZE	CODE	DOC. NUMBER	REV		
A3	CS	1310A2076701	A02		
CHANGE by		Kobby Wen		21-Feb-2006	
SHEET		50		OF 51	

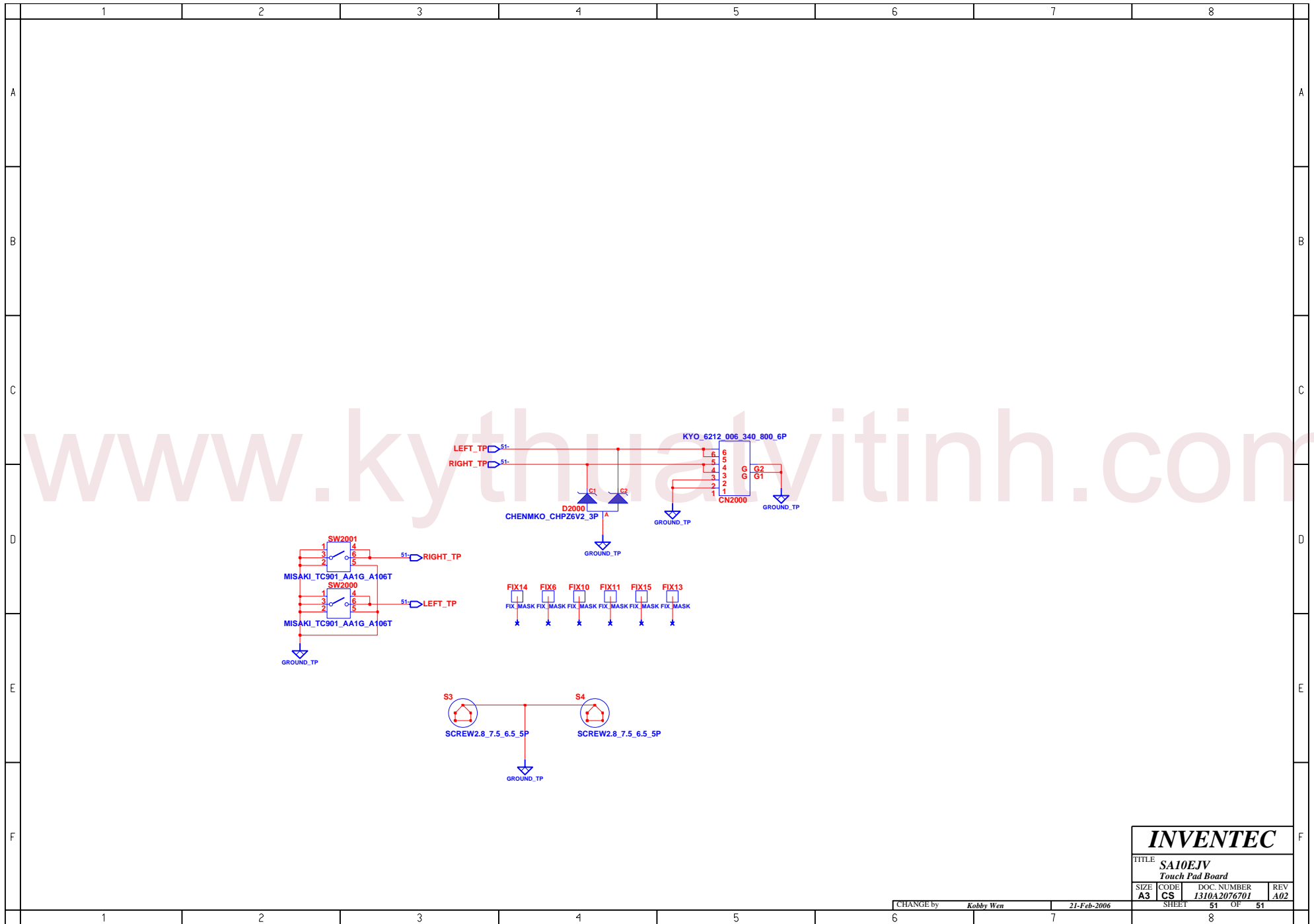

INVENTEC

TITLE			
SA10EJV			
Touch Pad Board			
SIZE	CODE	DOC. NUMBER	REV
A3	CS	1310A2076701	A02

CHANGE by	Kobby Wen	21-Feb-2006	SHEET	51	OF	51
-----------	-----------	-------------	-------	----	----	----