

Shiba Block Diagram(FF+)

Project Code: 91.4F701.001
 Project Name: Shiba
 PCB Number: 05234

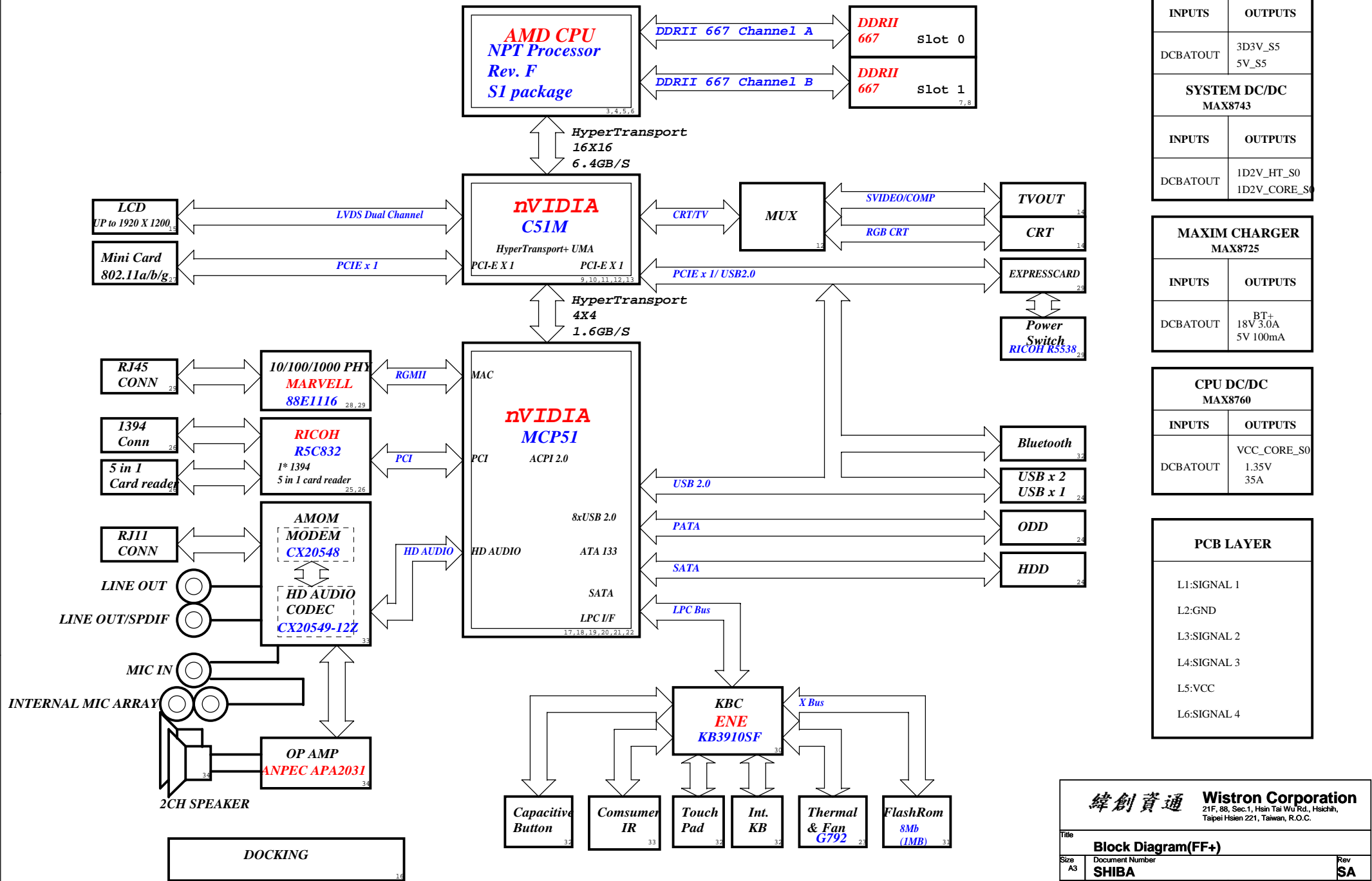

SYSTEM DC/DC MAX8734A	
INPUTS	OUTPUTS
DCBATOUT	3D3V_S5 5V_S5

SYSTEM DC/DC MAX8743	
INPUTS	OUTPUTS
DCBATOUT	1D2V_HT_S0 1D2V_CORE_S0

MAXIM CHARGER MAX8725	
INPUTS	OUTPUTS
DCBATOUT	BT+ 18V 3.0A 5V 100mA

CPU DC/DC MAX8760	
INPUTS	OUTPUTS
DCBATOUT	VCC_CORE_S0 1.35V 35A

PCB LAYER	
L1: SIGNAL 1	
L2: GND	
L3: SIGNAL 2	
L4: SIGNAL 3	
L5: VCC	
L6: SIGNAL 4	

緯創資通 **Wistron Corporation**
 21F, 88, Sec.1, Hsin Tai Wu Rd., Hsichih,
 Taipei Hsien 221, Taiwan, R.O.C.

Title: **Block Diagram(FF+)**

Size: A3	Document Number: SHIBA	Rev: SA
Date: Friday, November 11, 2005	Sheet: 1 of 44	

Shiba Block Diagram(DF)

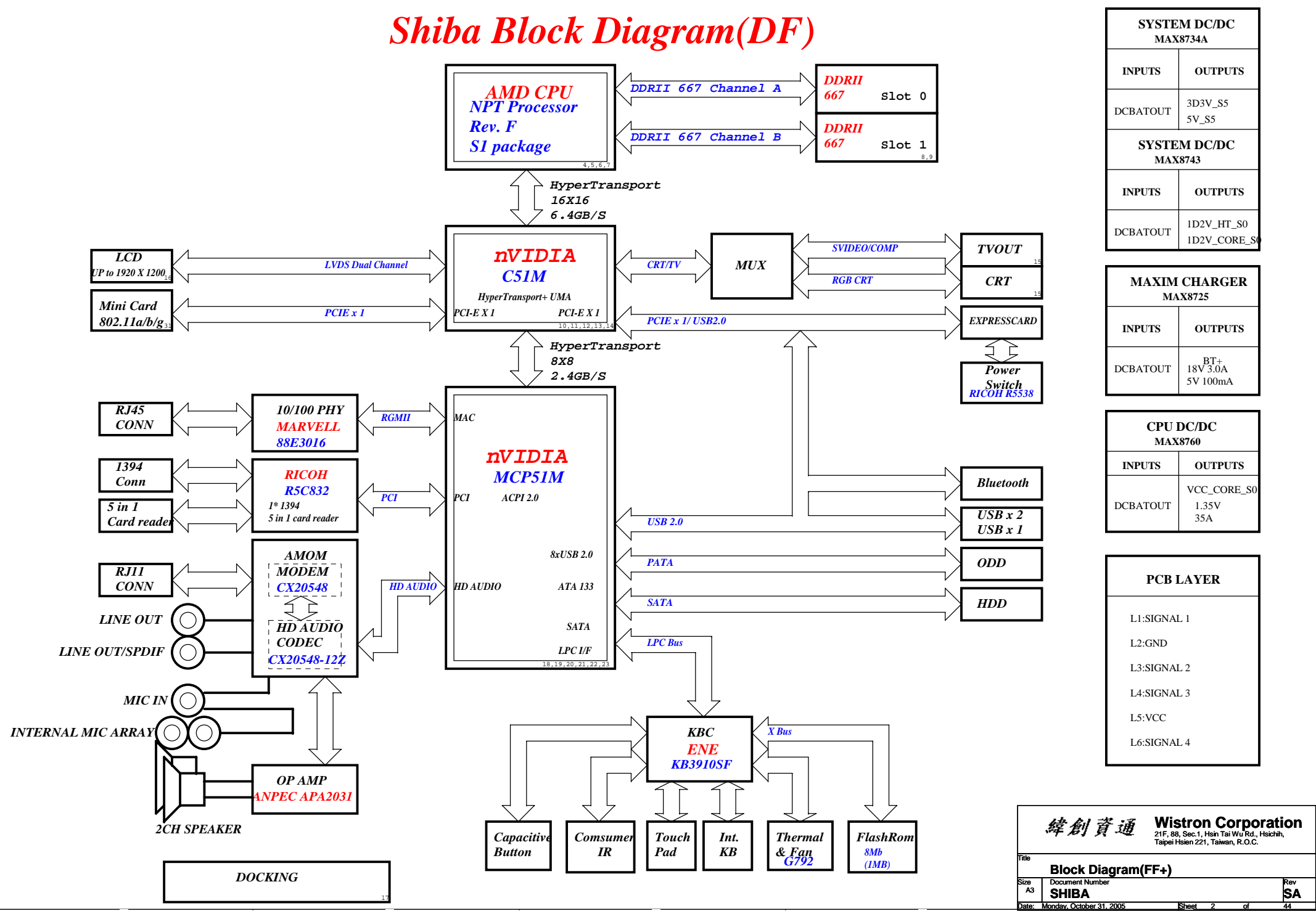

緯創資通 Wistron Corporation
 21F, 88, Sec.1, Hsin Tai Wu Rd., Hsichih,
 Taipei Hsien 221, Taiwan, R.O.C.

Title: **Block Diagram(FF+)**

Size: A3 Document Number: **SHIBA** Rev: **SA**

Date: Monday, October 31, 2005 Sheet: 2 of 44

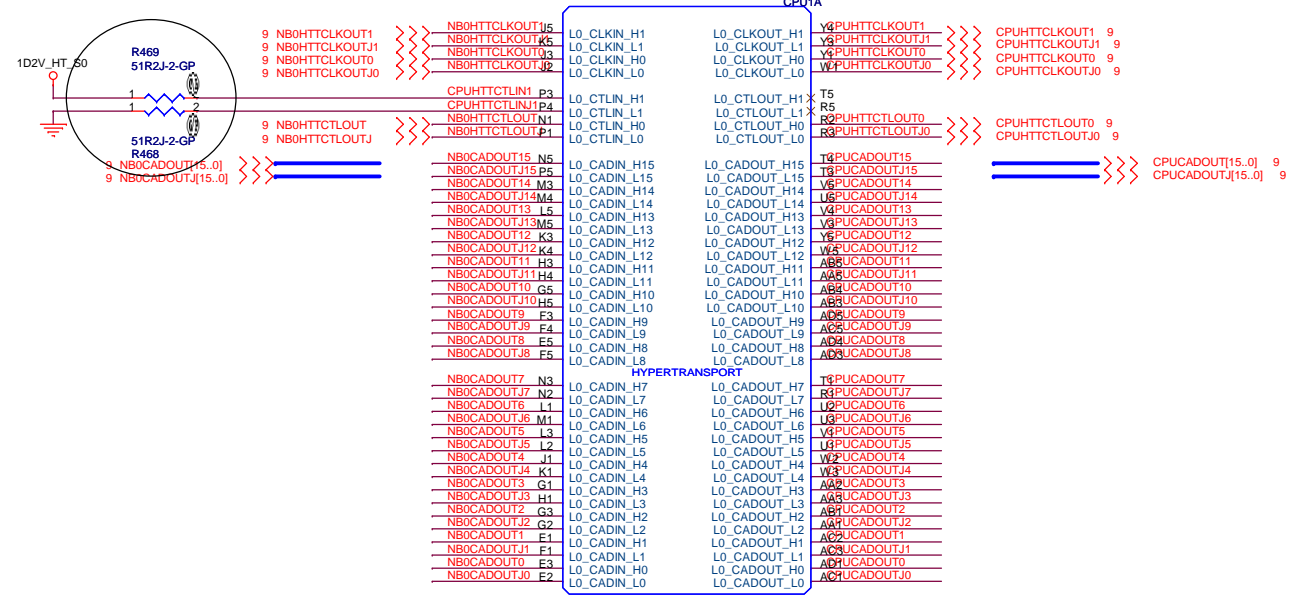

<Variant Name>

緯創資通		Wistron Corporation	
		21F, 88, Sec. 1, Hsin Tai Wu Rd., Hsichih, Taipei Hsien 221, Taiwan, R.O.C.	
Title			
CPU(1/4) HT			
Size	Document Number		Rev
A3	SHIBA		SC
Date: Friday, February 24, 2006		Sheet 3 of	44

D

D

C

C

B

B

A

A

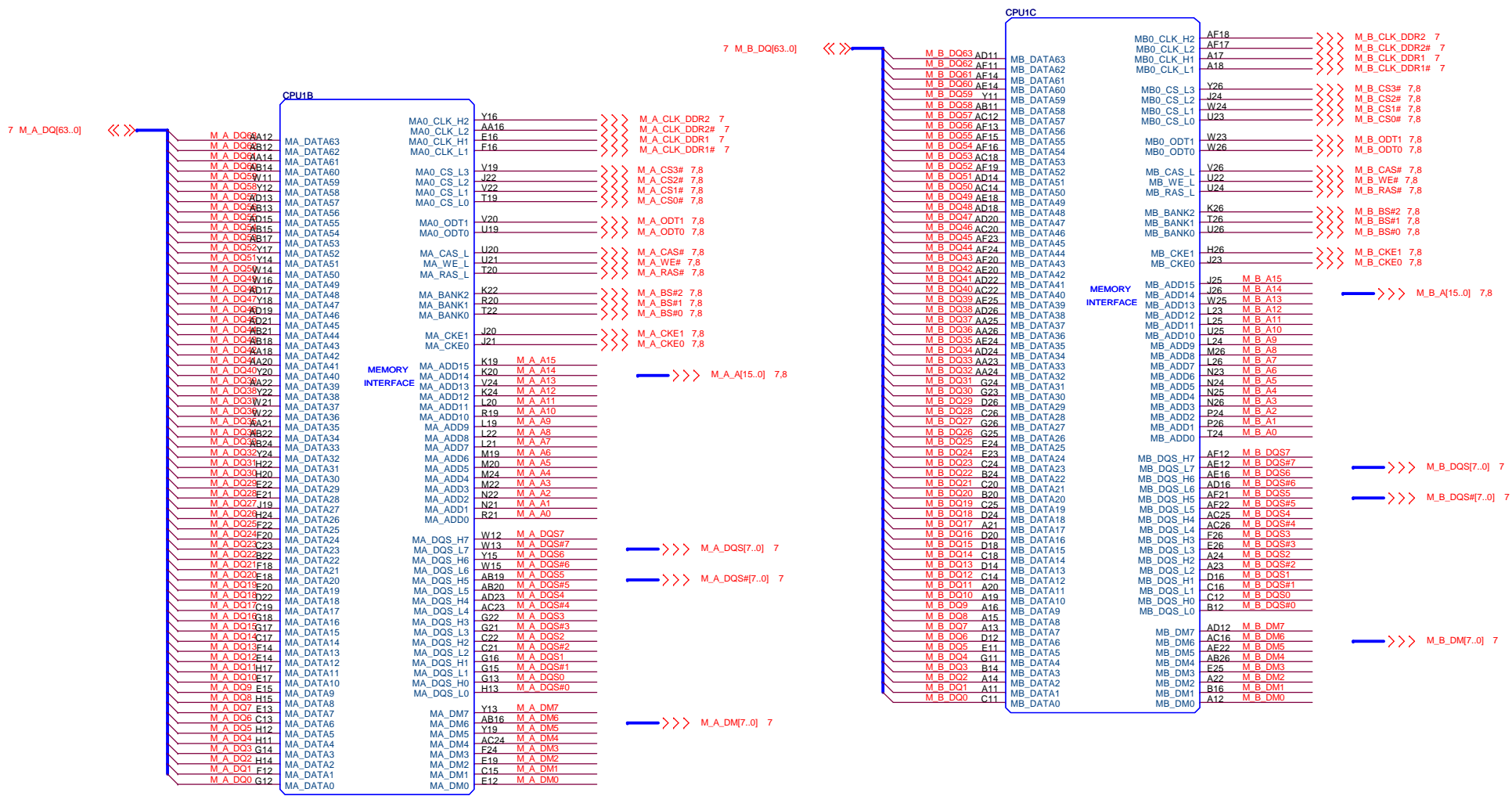

<Variant Name>

緯創資通		Wistron Corporation	
		21F, 88, Sec. 1, Hsin Tai Wu Rd., Hschih, Taipei Hsien 221, Taiwan, R.O.C.	
Title			
CPU(2/4) DDR II			
Size	Document Number		Rev
A3	SHIBA		SC
Date:	Friday, February 24, 2006	Sheet	4 of 44

D

D

C

C

B

B

A

A

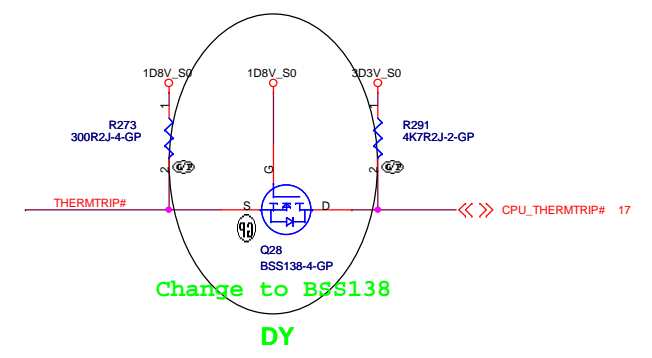
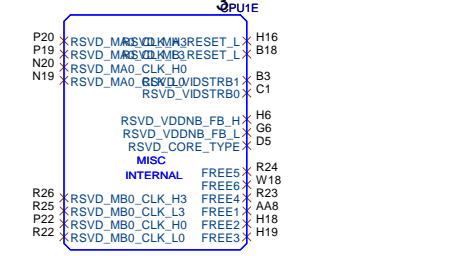

Change to BSS138
DY

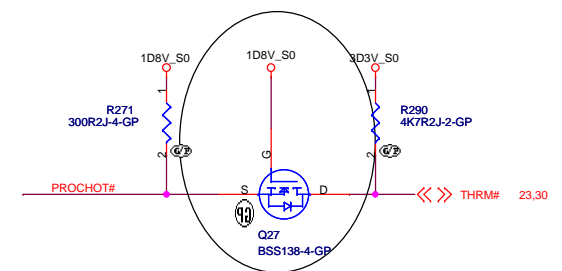

Change to BSS138
DY
VREF_DDR_CLAW

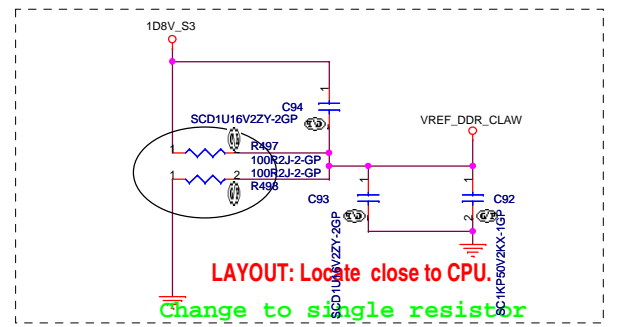

LAYOUT: Locate close to CPU.
Change to single resistor

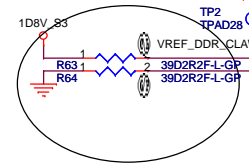

2nd source: Fairchild 74ALVC08
73.07408.DHB

AMD suggest to use 74HC09, it contains open drain output

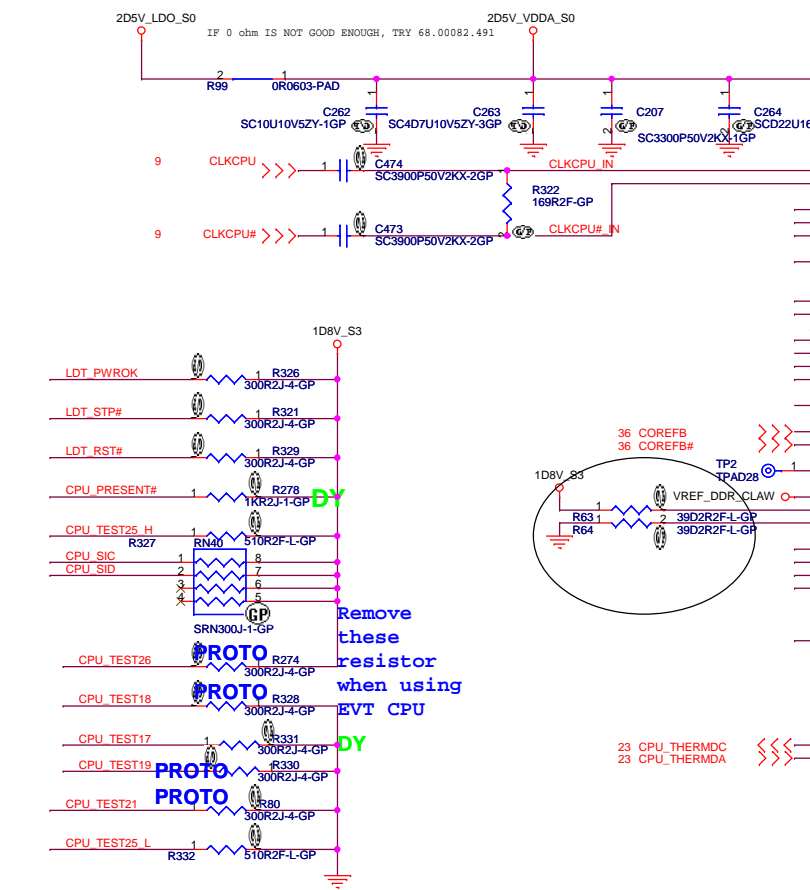

Remove these resistor when using EVT CPU

PROTO

PROTO

PROTO

HDT Connectors

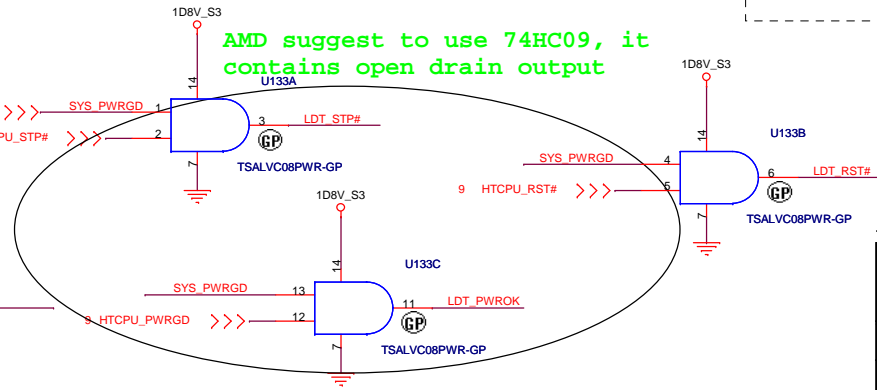
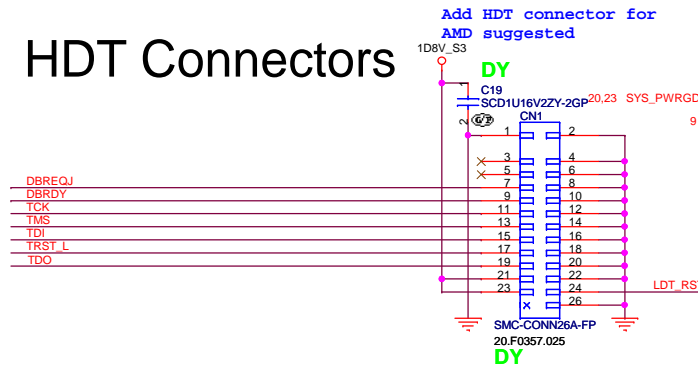

緯創資通 Wistron Corporation
21F, 88, Sec.1, Hsin Tai Wu Rd., Hsichih, Taipei Hsien 221, Taiwan, R.O.C.

Title: CPU(3/4) CONTROL

Size A3 Document Number SHIBA Rev SA

Date: Friday, February 24, 2006 Sheet 5 of 44

D

C

B

A

4 3 2 1

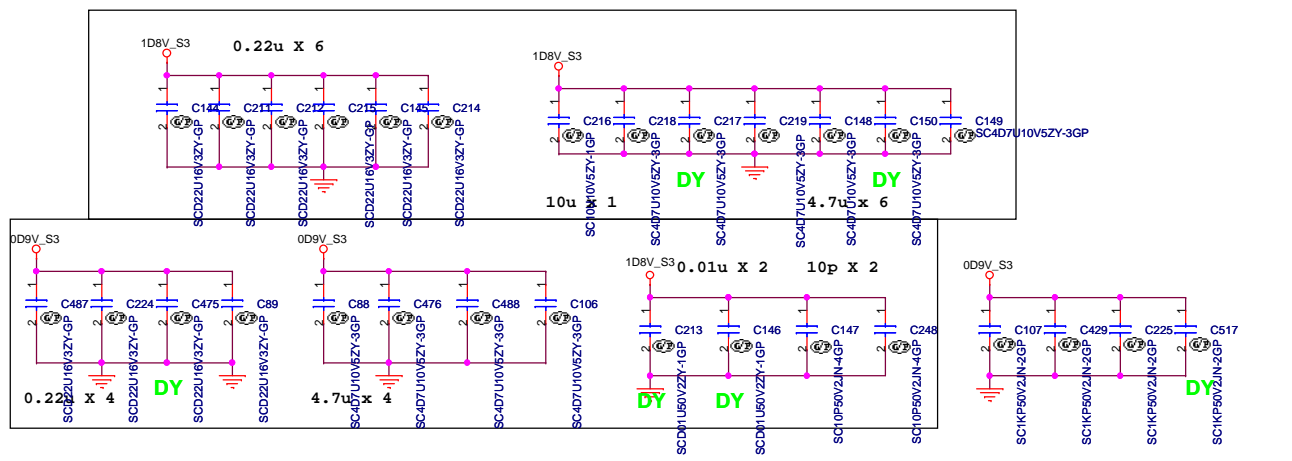
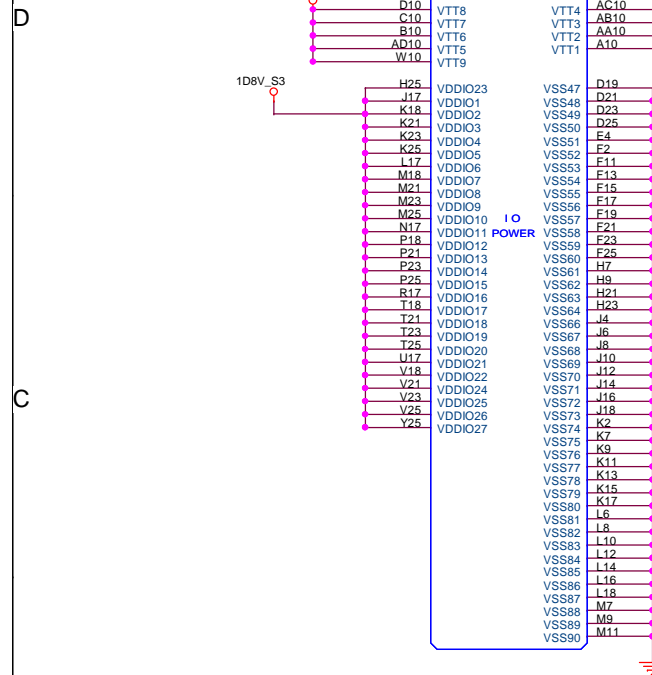
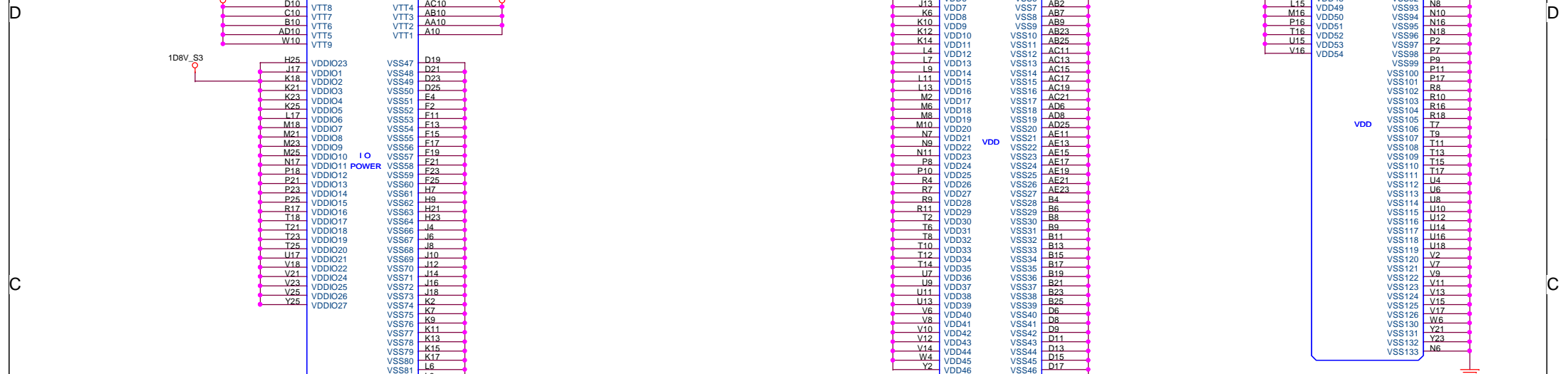

LAYOUT: Place on backside of processor.

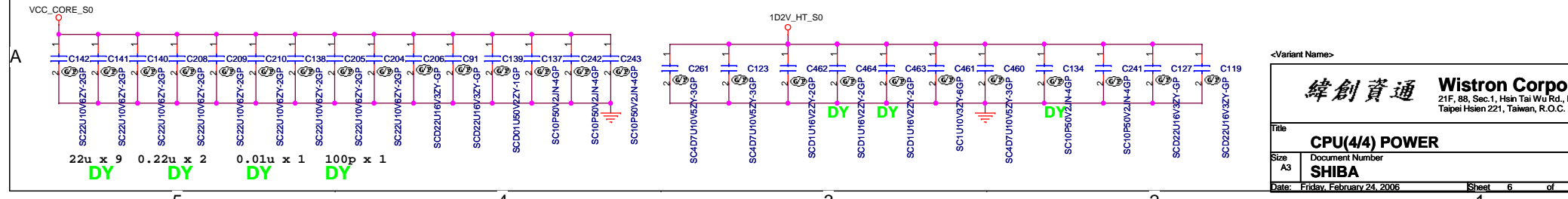

緯創資通 Wistron Corporation
 21F, 88, Sec. 1, Hsin Tai Wu Rd., Hsichih, Taipei Hsien 221, Taiwan, R.O.C.

Title: **CPU(4/4) POWER**

Size: A3
 Document Number: **SHIBA**
 Date: Friday, February 24, 2006

Rev: **SC**
 Sheet: 6 of 44

PARALLEL TERMINATION

Put decap near power(0.9V) and pull-up resistor

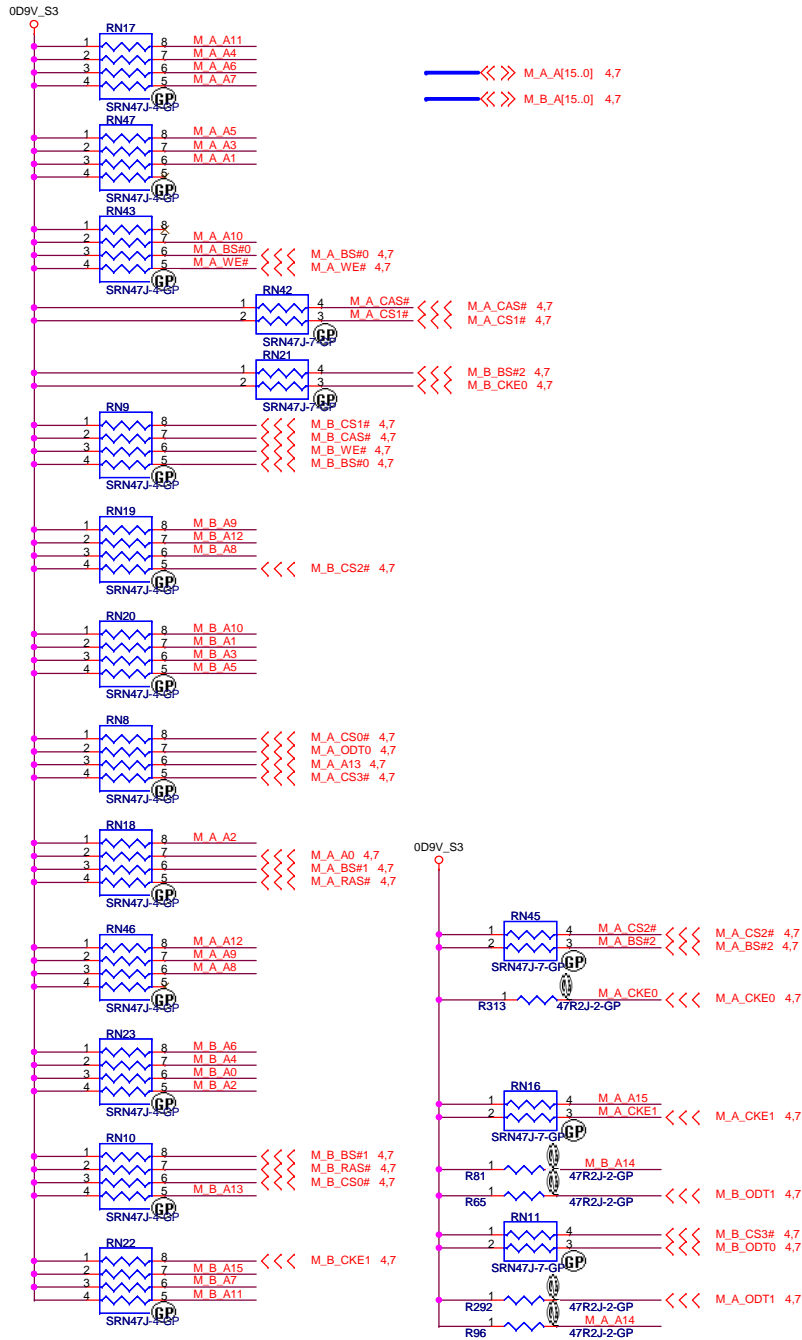

Decoupling Capacitor

Put decap near power(0.9V) and pull-up resistor

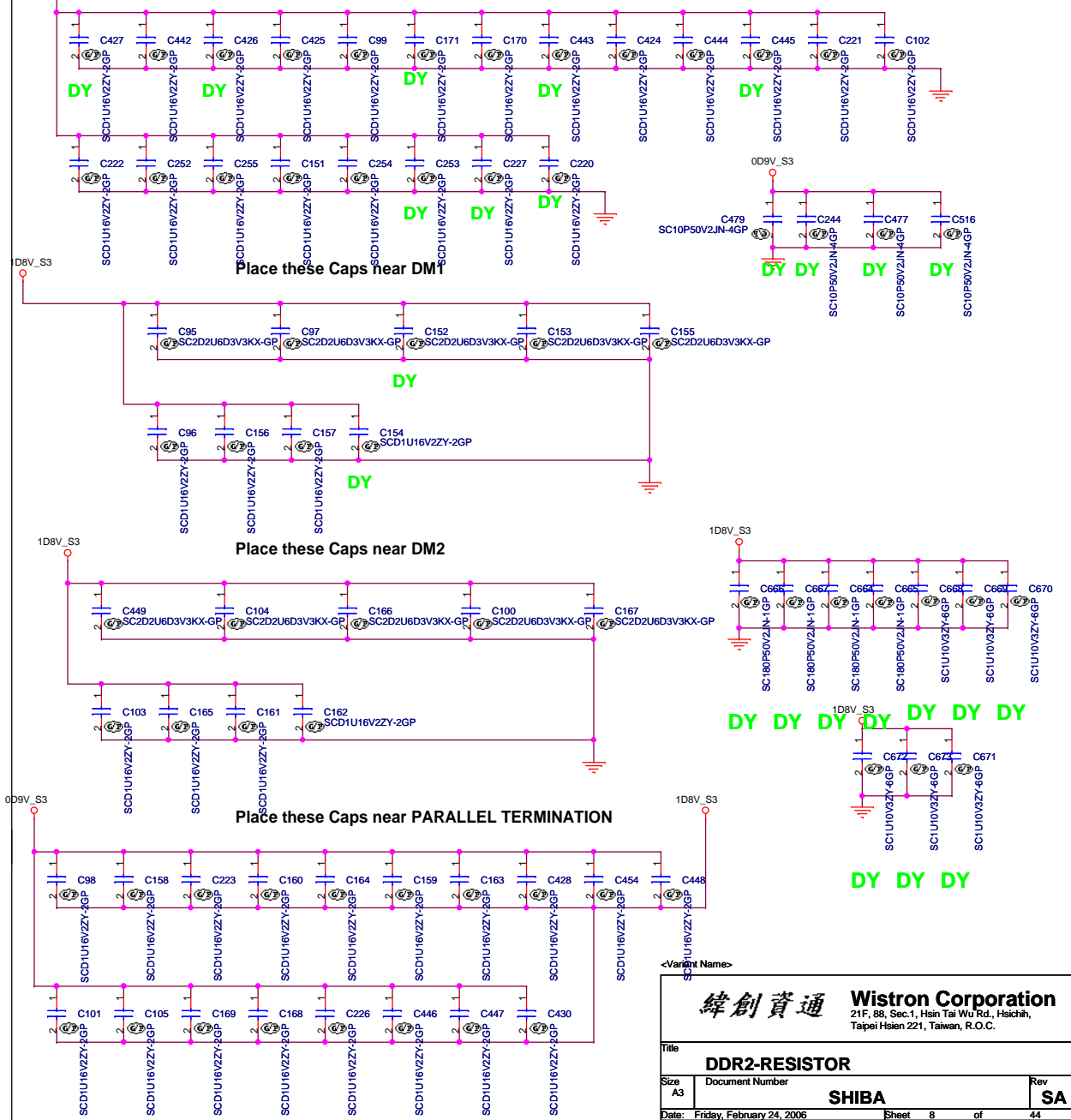

Wistron Corporation
 21F, 88, Sec.1, Hsin Tai Wu Rd., Hsichih, Taipei Hsien 221, Taiwan, R.O.C.

DDR2-RESISTOR

SHIBA

Rev SA

Date: Friday, February 24, 2006 Sheet 8 of 44

CPUCADOUT[15..0] 3
CPUCADOUTJ[15..0] 3

3 NB0CADOUT[15..0]
3 NB0CADOUTJ[15..0]

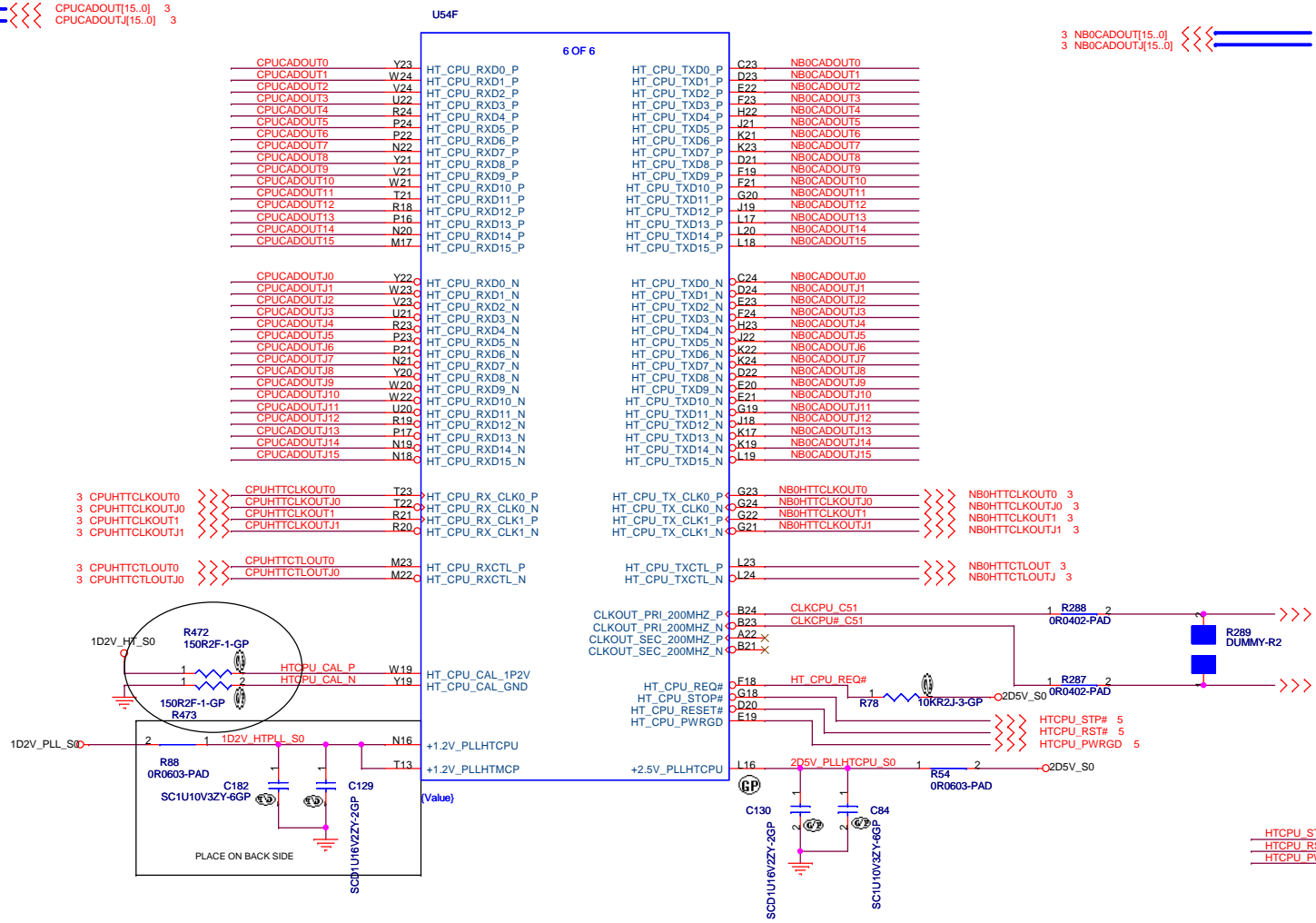

<Variant Name>

緯創資通 Wistron Corporation
21F, 88, Sec. 1, Hsin Tai Wu Rd., Hsichih, Taipei Hsien 221, Taiwan, R.O.C.

Title: **C51M(1/5) HT CPU**

Size A3	Document Number SHIBA	Rev SC
Date: Friday, February 24, 2006	Sheet 9 of 44	

D

D

C

C

B

B

A

A

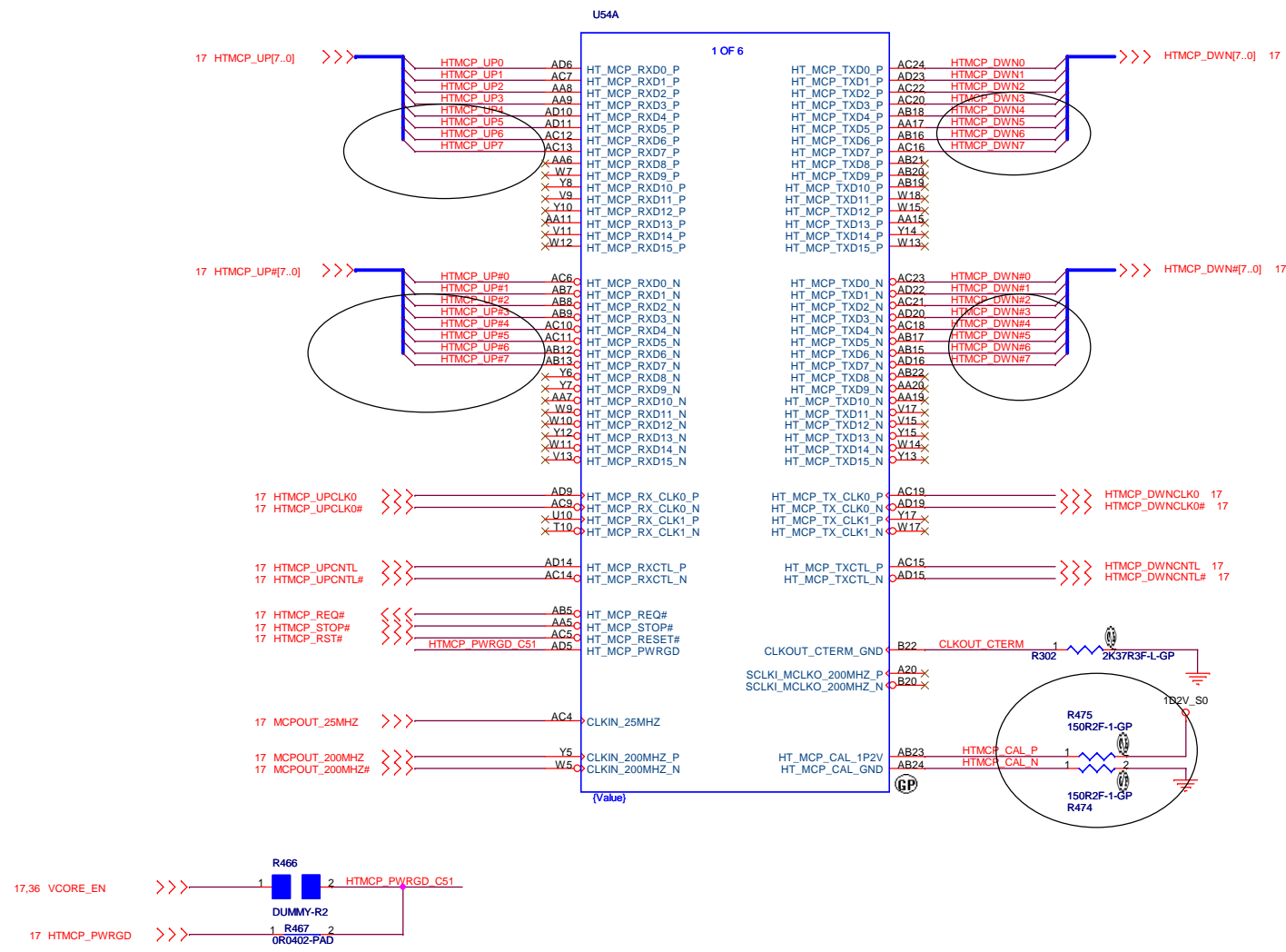

<Variant Name>

緯創資通 Wistron Corporation
21F, 88, Sec.1, Hsin Tai Wu Rd., Hsichih, Taipei Hsien 221, Taiwan, R.O.C.

Title: **C51M(2/5)HT MCP**

Size: A3	Document Number: SHIBA	Rev: SC
Date: Friday, February 24, 2006	Sheet: 10	of 44

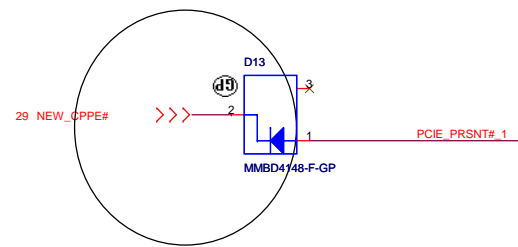

CHECK LEAKAGE CURRENT

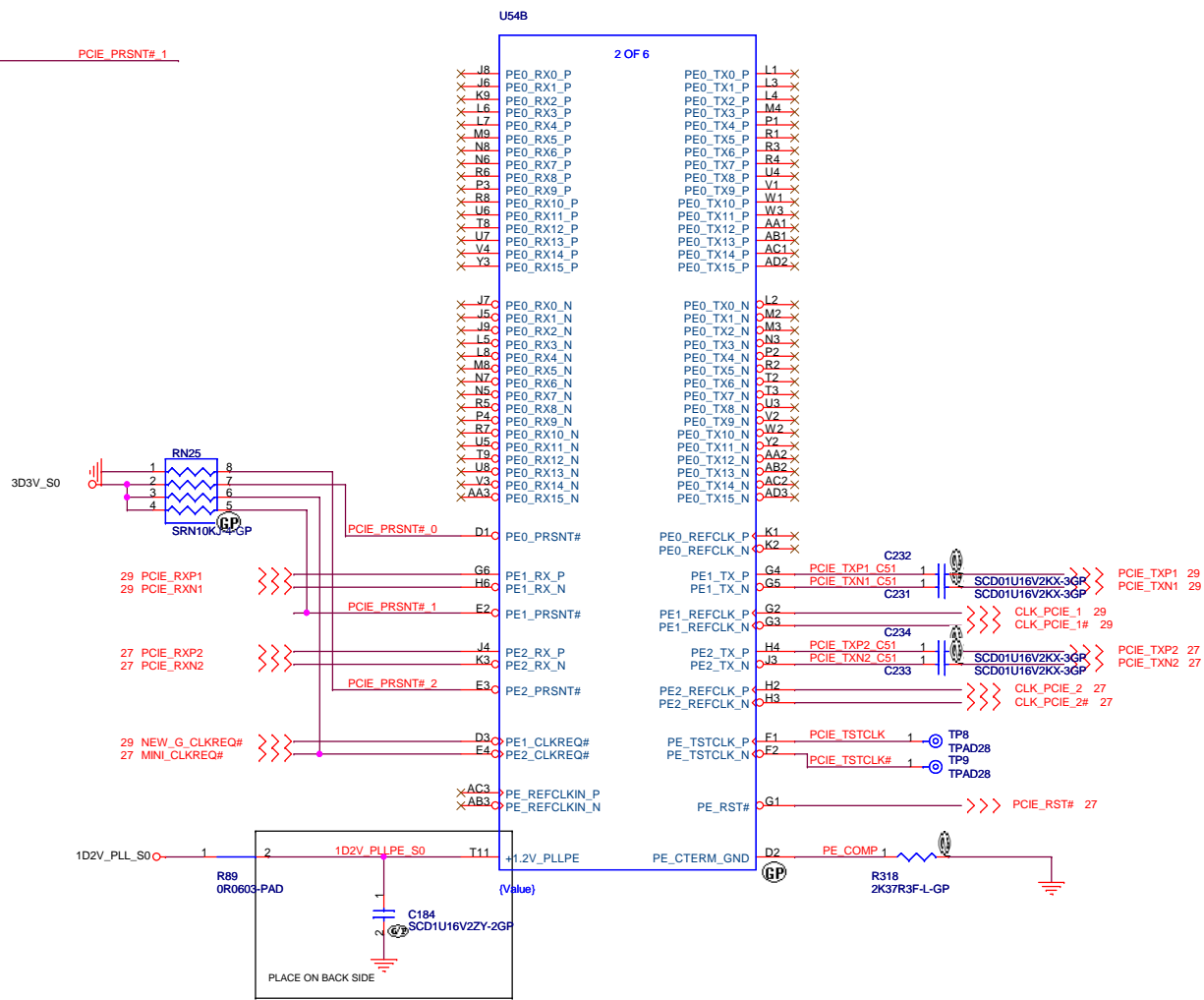

<Variant Name>

緯創資通 **Wistron Corporation**
 21F, 88, Sec. 1, Hsin Tai Wu Rd., Hsichih,
 Taipei Hsien 221, Taiwan, R.O.C.

Title: **C51M(3/5)PCIE**

Size: A3	Document Number: SHIBA	Rev: SA
Date: Monday, February 27, 2006	Sheet: 11	of 44

D

D

C

C

B

B

A

A

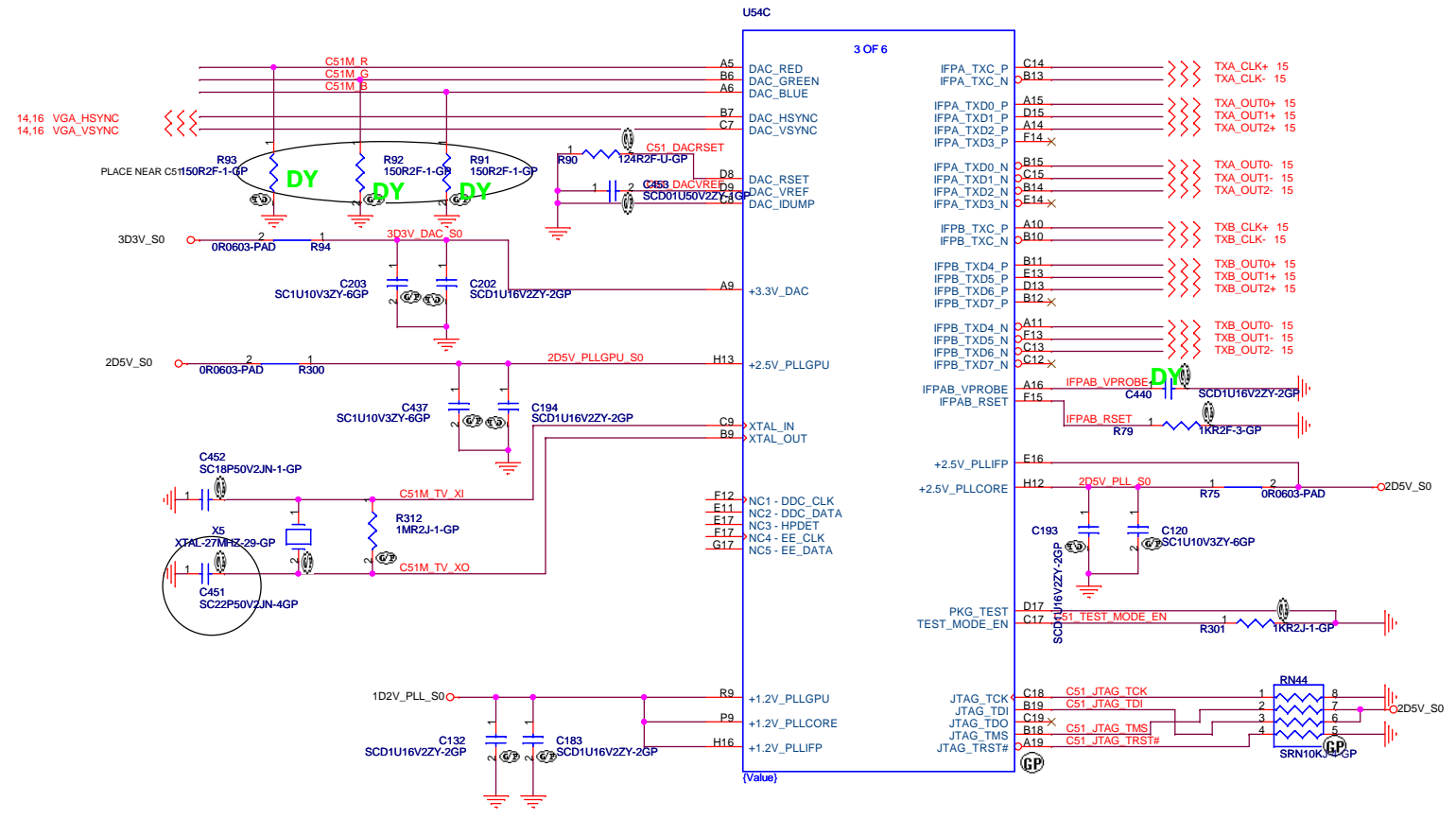

PLACE NEAR CONNECTOR

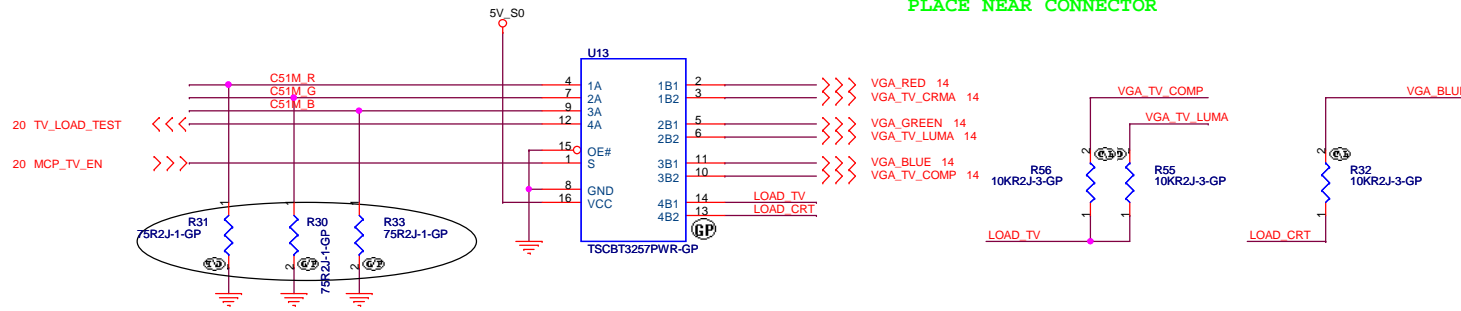

<Variant Name>

緯創資通 Wistron Corporation
21F, 88, Sec.1, Hsin Tai Wu Rd., Hsichih, Taipei Hsien 221, Taiwan, R.O.C.

Title C51M(4/5)CRT/LVDS		
Size A3	Document Number SHIBA	Rev SA
Date: Wednesday, March 15, 2006	Sheet 12 of 44	1

D

D

C

C

B

B

A

A

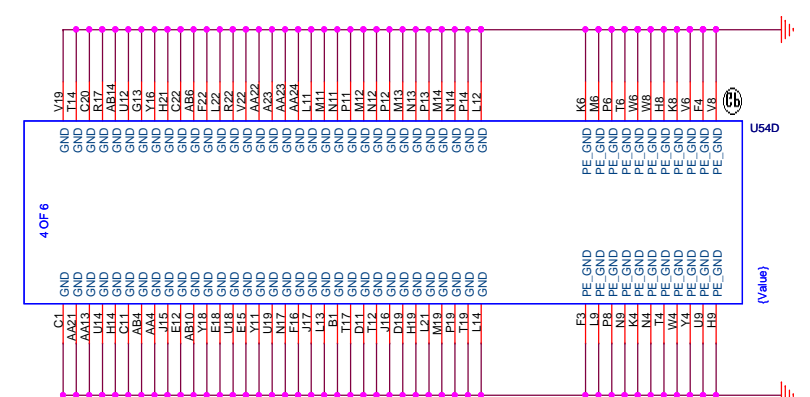
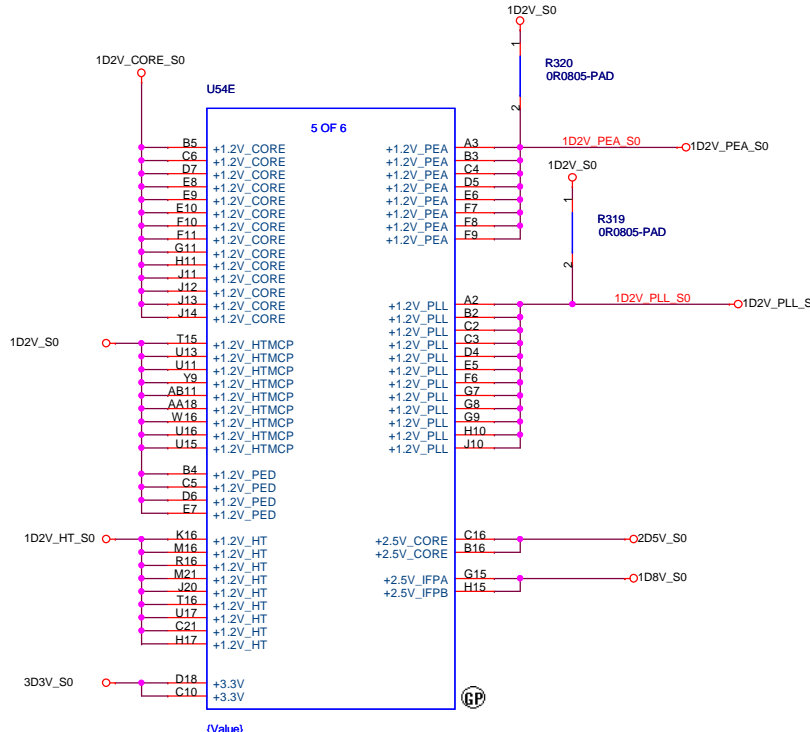

C51 DECOUPLING

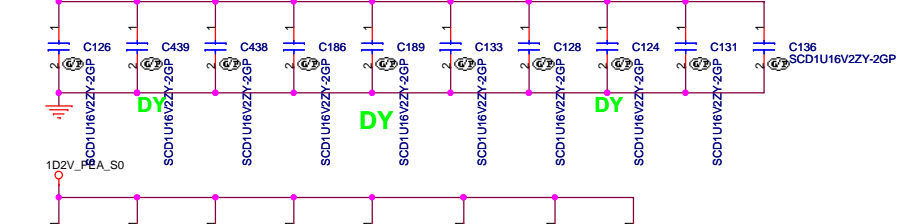
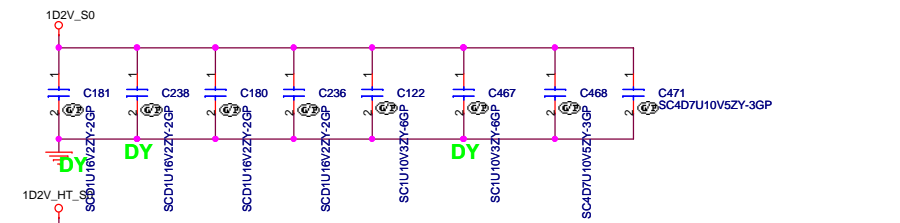
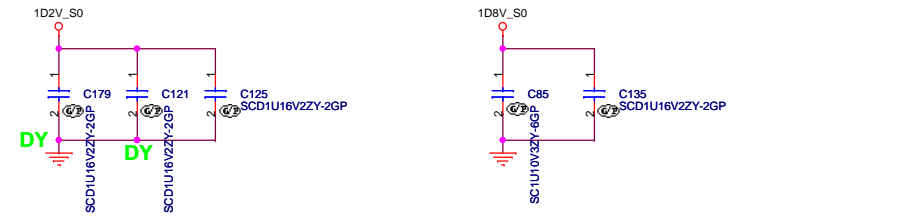
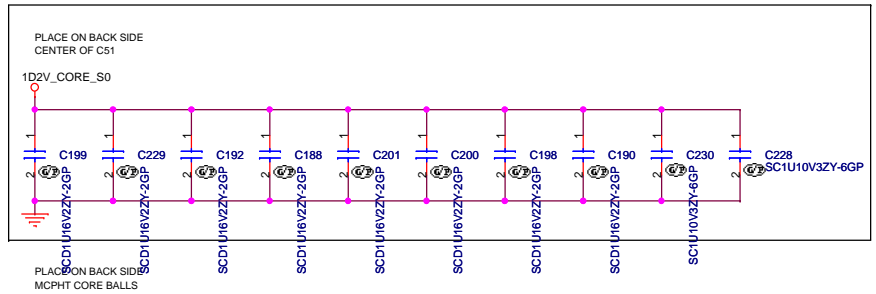

緯創資通 Wistron Corporation
21F, 88, Sec.1, Hsin Tai Wu Rd., Hsichih, Taipei Hsien 221, Taiwan, R.O.C.

Title: **C51M(5/5)POWER**

Size: A3	Document Number: SHIBA	Rev: SA
Date: Saturday, February 18, 2006	Sheet: 13 of 44	

CRT I/F & CONNECTOR

Layout Note:
Place these resistors
close to the CRT-out
connector

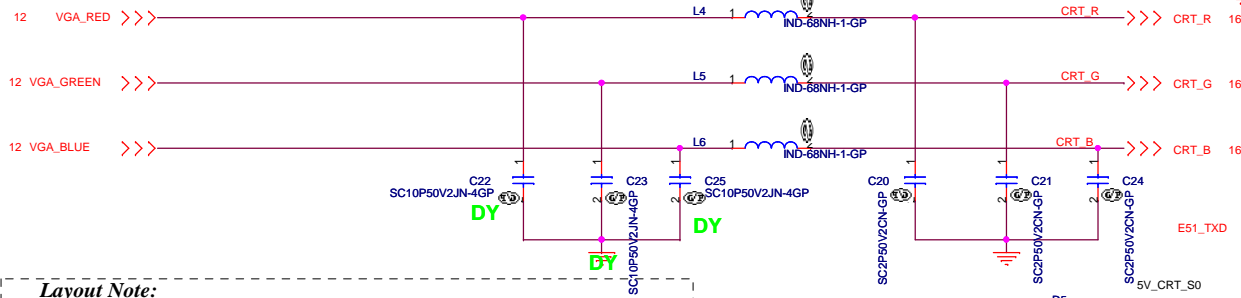

Layout Note:
* Must be a ground return path between this ground and the ground on the VGA connector.
Pi-filter & 150 Ohm pull-down resistors should be as close as to CRT CONN. RGB will hit 75 Ohm first, pi-filter, then CRT CONN.

Hsync & Vsync level shift

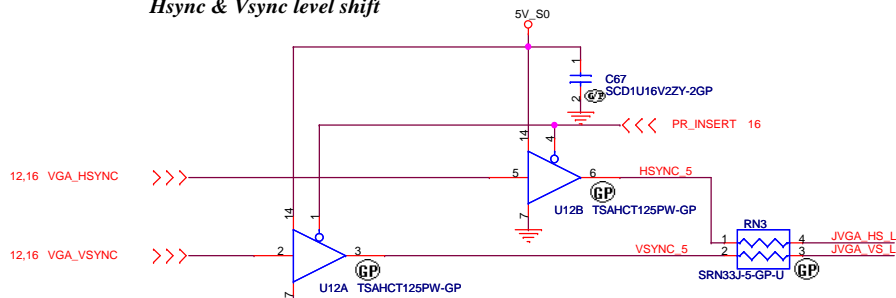

TV OUT CONN

Layout Note:
Place this 2 resistors
close to the TV-out
connector

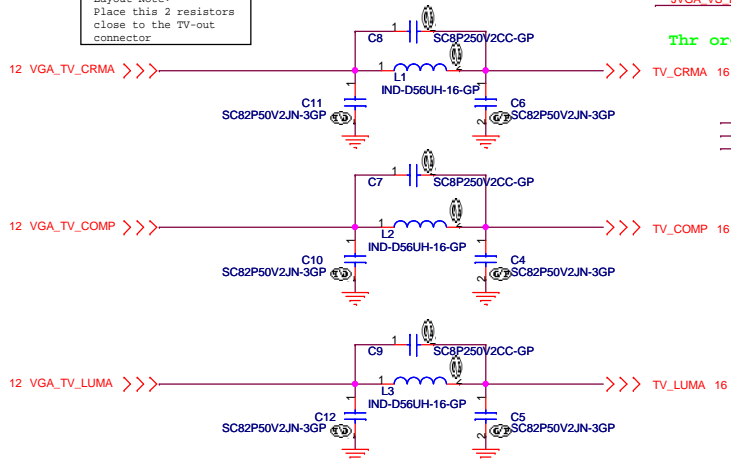

Thr org part is 68.2703N.10B

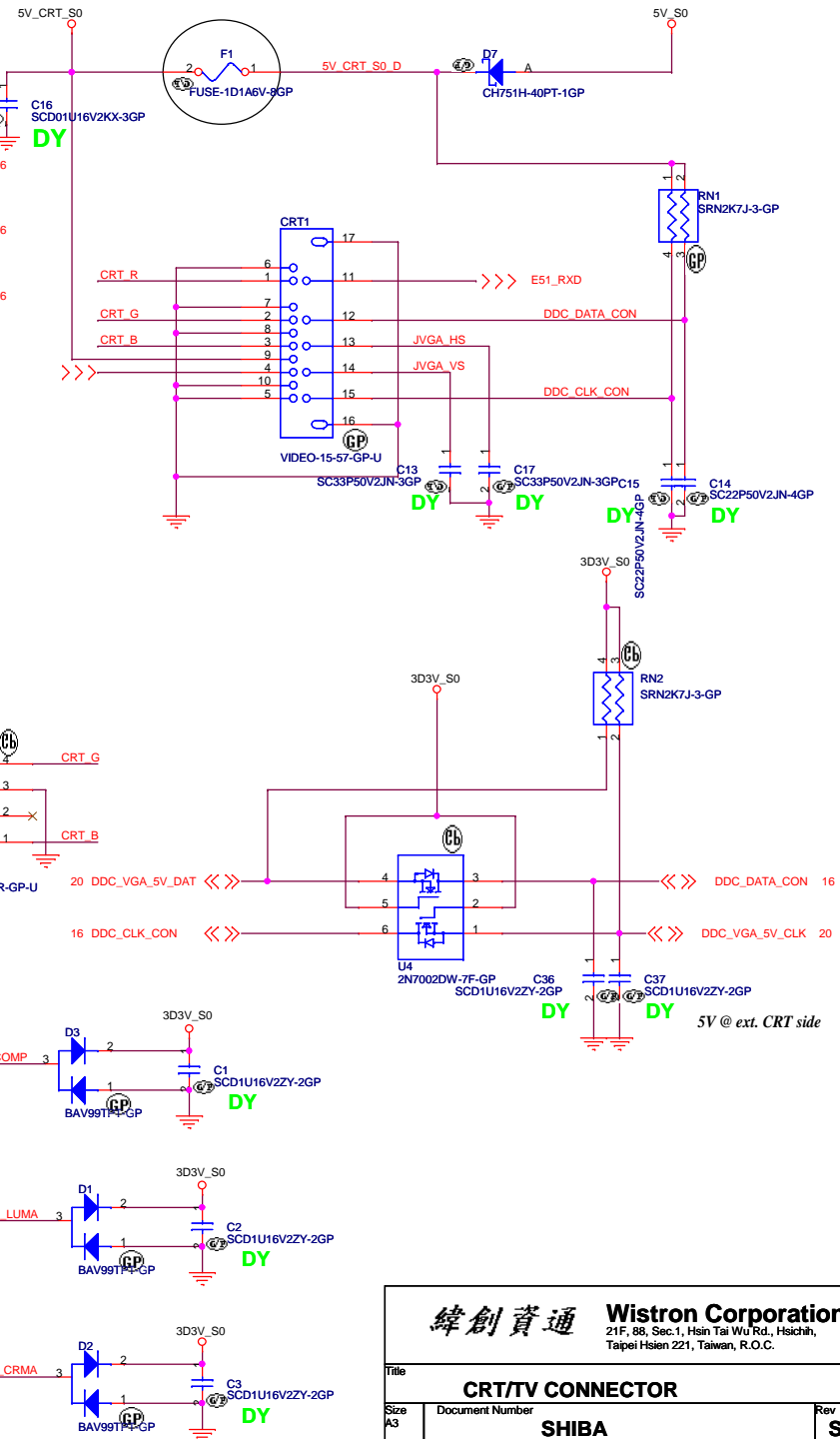
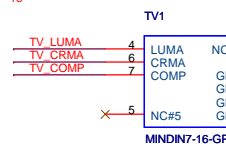

LED / INVERTER INTERFACE

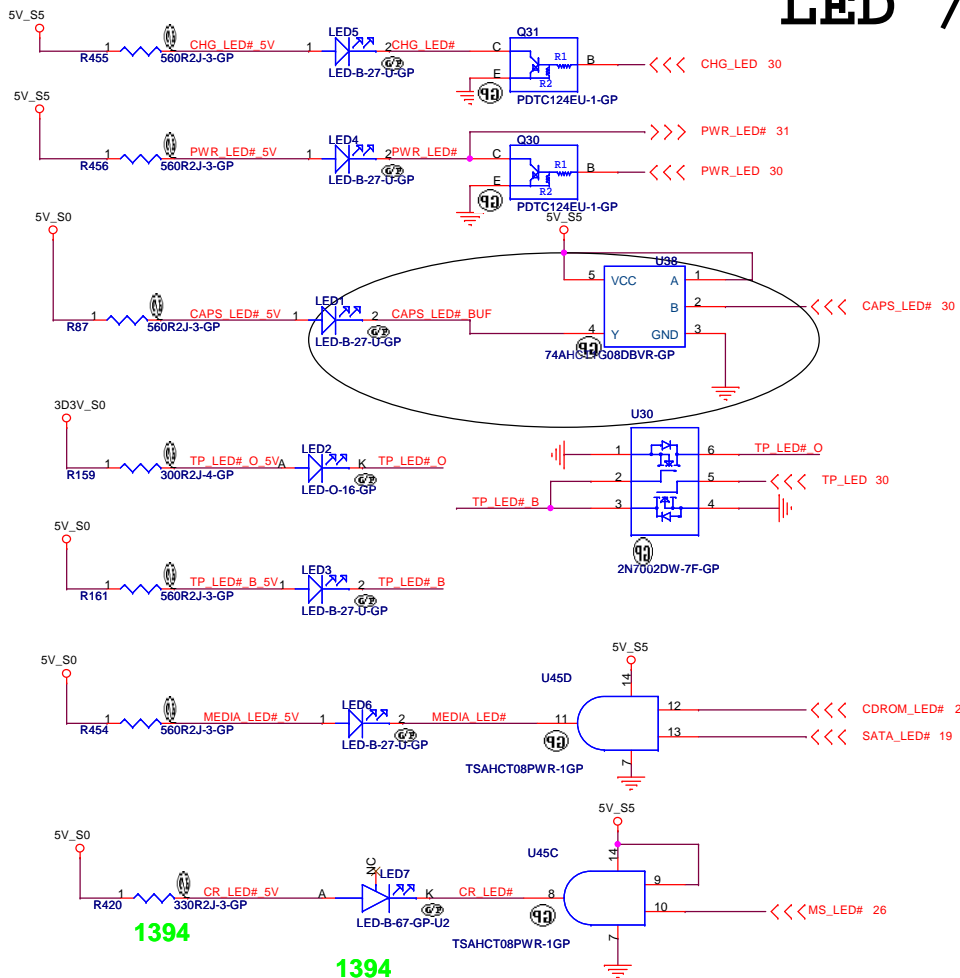

- 12 TXB_OUT2+
- 12 TXB_OUT2-
- 12 TXB_OUT1+
- 12 TXB_OUT1-
- 12 TXB_OUT0+
- 12 TXB_OUT0-
- 12 TXB_CLK+
- 12 TXB_CLK-
- 12 TXA_OUT2+
- 12 TXA_OUT2-
- 12 TXA_OUT1+
- 12 TXA_OUT1-
- 12 TXA_OUT0+
- 12 TXA_OUT0-
- 12 TXA_CLK+
- 12 TXA_CLK-

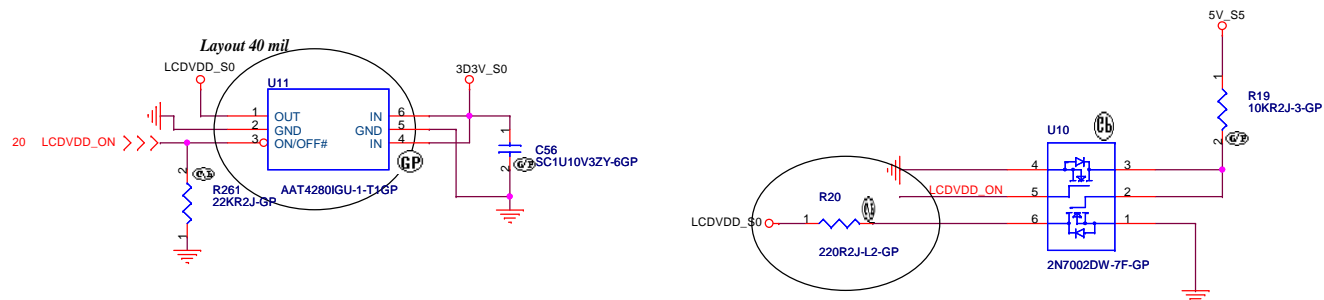
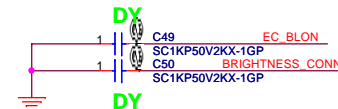
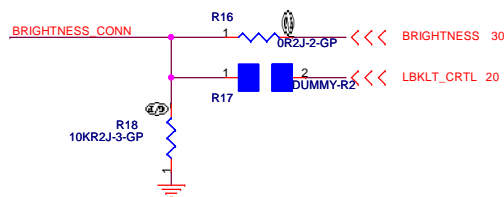
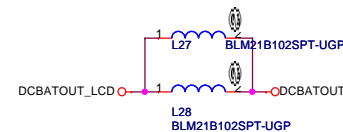
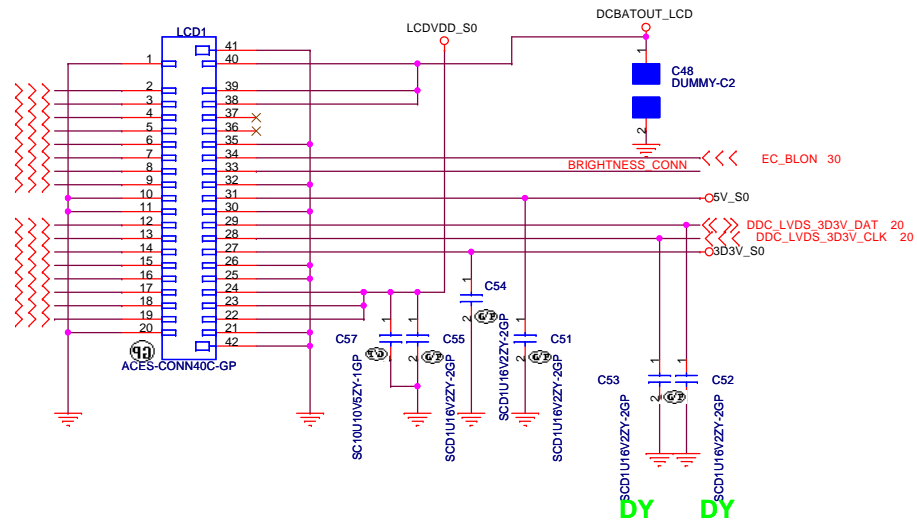

緯創資通 Wistron Corporation		
21F, 88, Sec.1, Hsin Tai Wu Rd., Hsichih, Taipei Hsien 221, Taiwan, R.O.C.		
LCD/Inverter Connector		
Title	Document Number	Rev
Size Custom	SHIBA	SA
Date: Friday, February 24, 2006	Sheet 15 of 44	

Docking Connector

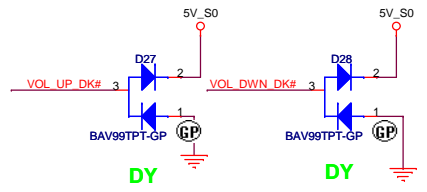

Hsync & Vsync level shift

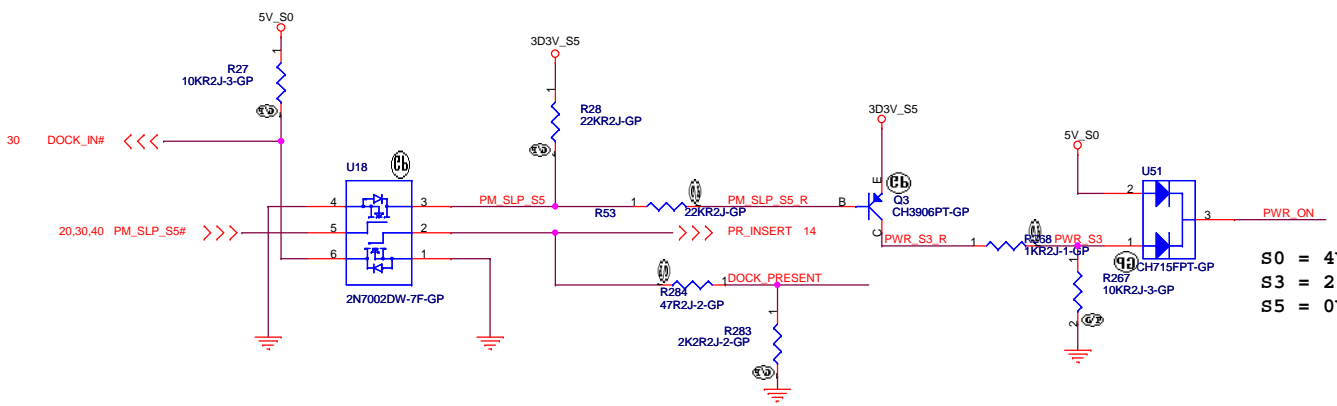
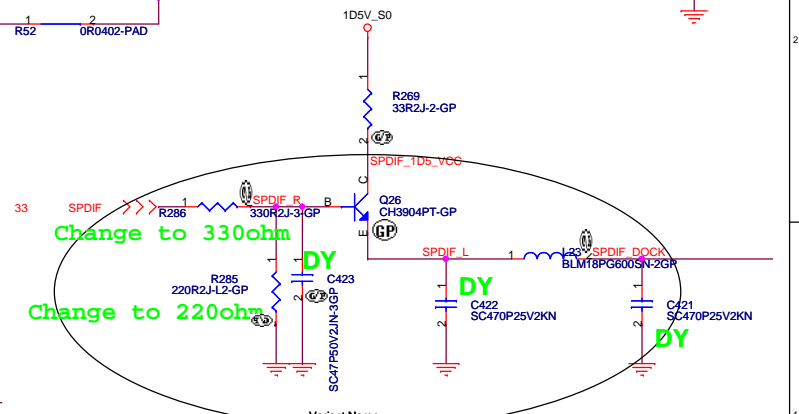
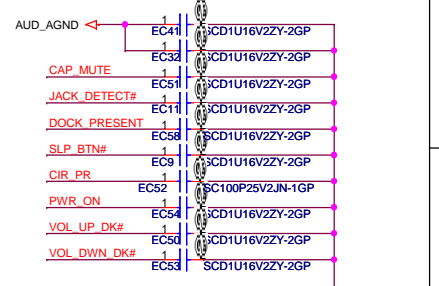
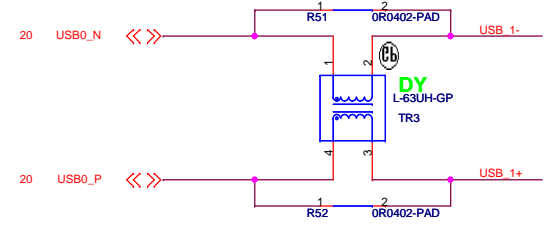
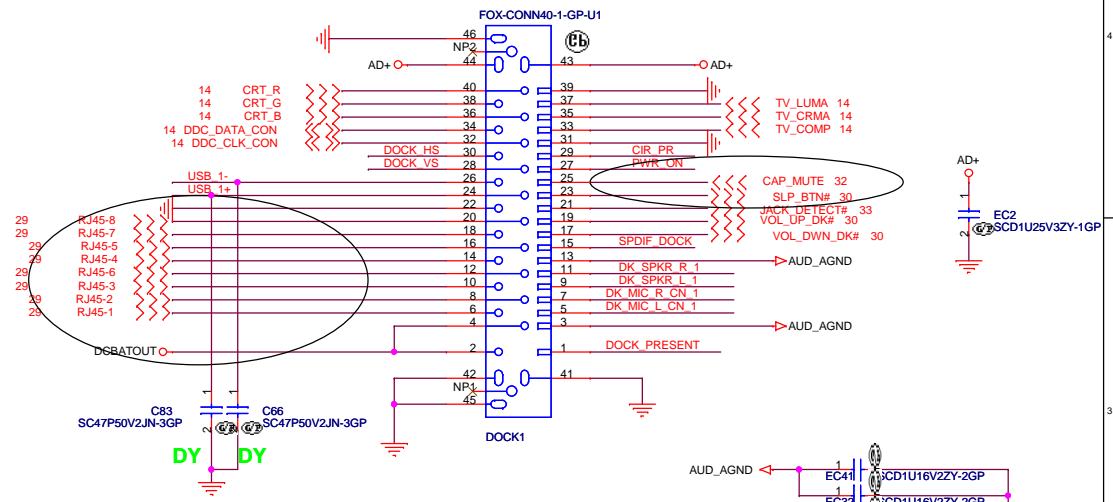
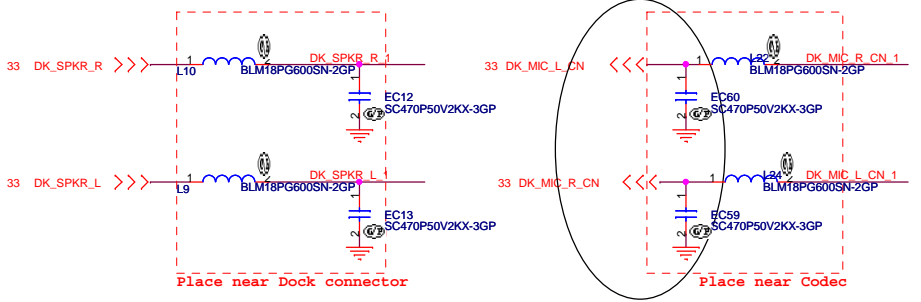
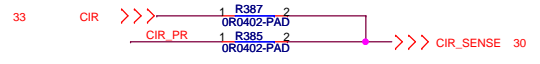
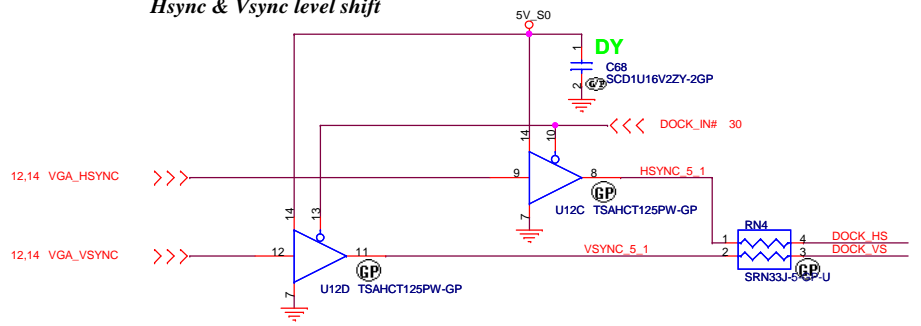

S0 = 4V
S3 = 2.5V
S5 = 0V

		Wistron Corporation 21F, 88, Sec.1, Hsin Tai Wu Rd., Hsichih, Taipei Hsien 221, Taiwan, R.O.C.	
Board to board conn/ Docking			
Title	Document Number	Rev	SA
Size	A3	SHIBA	
Date:	Monday, February 27, 2006	Sheet	16 of 44

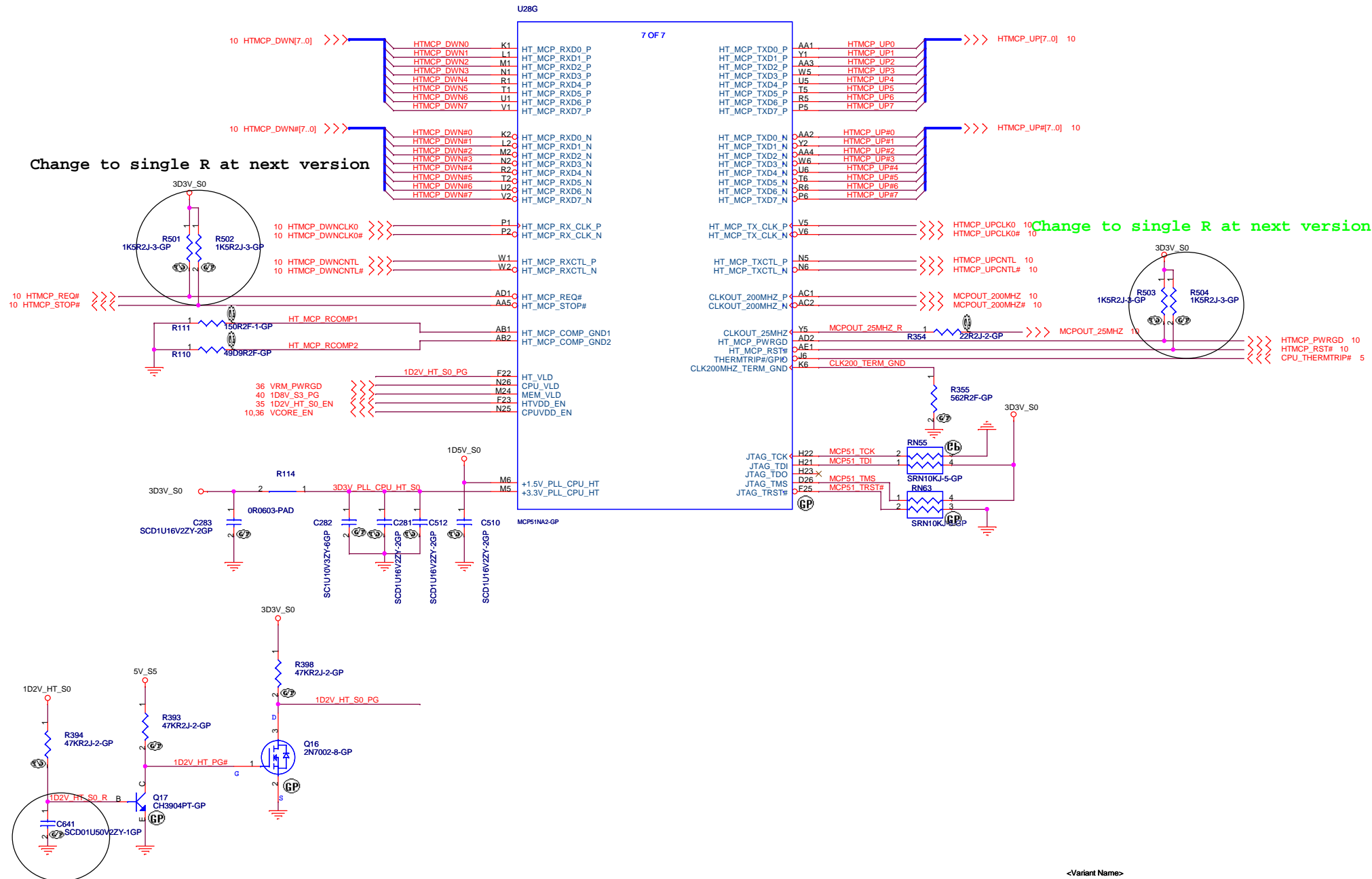

<Variant Name>

緯創資通 **Wistron Corporation**
 21F, 88, Sec. 1, Hsin Tai Wu Rd., Hsichih,
 Taipei Hsien 221, Taiwan, R.O.C.

Title MCP51(1/6)HT		
Size A3	Document Number SHIBA	Rev SA
Date: Monday, February 20, 2006	Sheet 17 of 44	

D

D

C

C

B

B

A

A

25 PCI_AD[0..31] <<<>>

25 PCI_C/BE#0 <<<>> AD19
25 PCI_C/BE#1 <<<>> AB17
25 PCI_C/BE#2 <<<>> AA15
25 PCI_C/BE#3 <<<>> AA13

25 PCI_FRAME# <<<>> AC15
25 PCI_IRDY# <<<>> AD15
25 PCI_TRDY# <<<>> AB16
25 PCI_STOP# <<<>> AE16
25 PCI_DEVSEL# <<<>> AA16
25 PCI_PAR <<<>> AE16
25 PCI_PERR# <<<>> AF17
25 PCI_SERR# <<<>> AD11
25.30 PM_CLKRUN# <<<>> AE25

25 PCIRST# <<<>> PCIRST# R R388
24 PCIRST#_IDE <<<>> PCIRST#_IDE R AD24
29 PCIRST#_NEW <<<>> PCIRST#_NEW R AE26
30,31 LPC_RST# <<<>> LPC_RST# R L26

PCI_AD0	AF19	PCI_AD0
PCI_AD1	AB21	PCI_AD1
PCI_AD2	AC19	PCI_AD2
PCI_AD3	AA20	PCI_AD3
PCI_AD4	AA19	PCI_AD4
PCI_AD5	AE20	PCI_AD5
PCI_AD6	AE19	PCI_AD6
PCI_AD7	AE20	PCI_AD7
PCI_AD8	AB20	PCI_AD8
PCI_AD9	AB19	PCI_AD9
PCI_AD10	AA18	PCI_AD10
PCI_AD11	AB18	PCI_AD11
PCI_AD12	AE18	PCI_AD12
PCI_AD13	AF18	PCI_AD13
PCI_AD14	AC17	PCI_AD14
PCI_AD15	AA17	PCI_AD15
PCI_AD16	AB15	PCI_AD16
PCI_AD17	AE15	PCI_AD17
PCI_AD18	AE15	PCI_AD18
PCI_AD19	AF14	PCI_AD19
PCI_AD20	AE14	PCI_AD20
PCI_AD21	AA14	PCI_AD21
PCI_AD22	AB14	PCI_AD22
PCI_AD23	AC13	PCI_AD23
PCI_AD24	AB13	PCI_AD24
PCI_AD25	AE13	PCI_AD25
PCI_AD26	AF13	PCI_AD26
PCI_AD27	AA12	PCI_AD27
PCI_AD28	AB12	PCI_AD28
PCI_AD29	AE12	PCI_AD29
PCI_AD30	AE12	PCI_AD30
PCI_AD31	AF11	PCI_AD31

U28A
1 OF 7

PCI_REQ#0	AA22	PCI_REQ#0
PCI_REQ#1	AE22	PCI_REQ#1
PCI_REQ#2	AF21	PCI_REQ#2
PCI_REQ#3/GPIO	AE22	PCI_REQ#3
PCI_REQ#4/GPIO	AE23	PCI_REQ#4
PCI_GNT#0	AE21	PCI_GNT#0
PCI_GNT#1	AC21	PCI_GNT#1
PCI_GNT#2	AA21	PCI_GNT#2
PCI_GNT#3/GPIO	AB24	PCI_GNT#3
PCI_GNT#4/GPIO	AB24	PCI_GNT#4
PCI_INTW#	AE11	PCI_INTW#
PCI_INTX#	AB11	PCI_INTX#
PCI_INTY#	AC11	PCI_INTY#
PCI_INTZ#	AA11	PCI_INTZ#
PCI_CLK#0	AE24	PCI_CLK#0
PCI_CLK#1	AE24	PCI_CLK#1
PCI_CLK#2	AD23	PCI_CLK#2
PCI_CLK#3	AE23	PCI_CLK#3
PCI_CLK#4	AB23	PCI_CLK#4
PCI_CLKIN	AC23	PCI_CLKIN
LPC_AD0	K24	LPC_LAD0 R
LPC_AD1	H26	LPC_LAD1 R
LPC_AD2	H25	LPC_LAD2 R
LPC_AD3	K22	LPC_LAD3 R
LPC_FRAME#	G25	LPC_LFRAME#
LPC_DRQ#0	K21	LPC_LDRQ0#
LPC_DRQ#1/LPC_CS#	K23	LPC_LDRQ1#
LPC_SERIRQ	L22	INT_SERIRQ
LPC_PWRDWN#/GPIO	H24	
LPC_CLK#0	F26	LPC_CLK#0
LPC_CLK#1	G26	PCI_CLK1# R

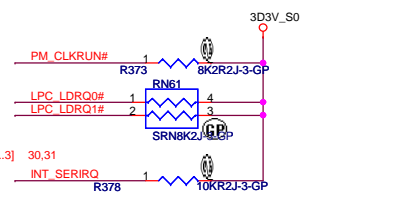
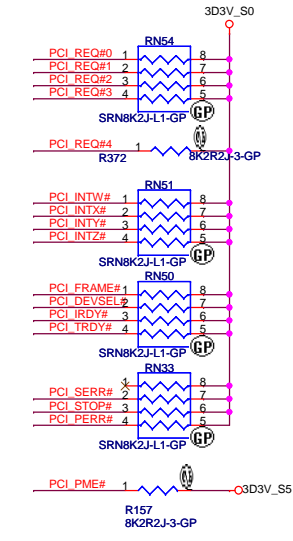
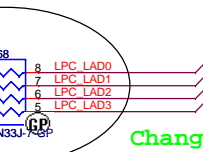

<Variant Name>

緯創資通		Wistron Corporation
21F, 88, Sec. 1, Hsin Tai Wu Rd., Hsichih, Taipei Hsien 221, Taiwan, R.O.C.		
Title MCP51(2/6)PCI		
Size A3	Document Number SHIBA	Rev SA
Date: Monday, February 20, 2006	Sheet 18 of 44	

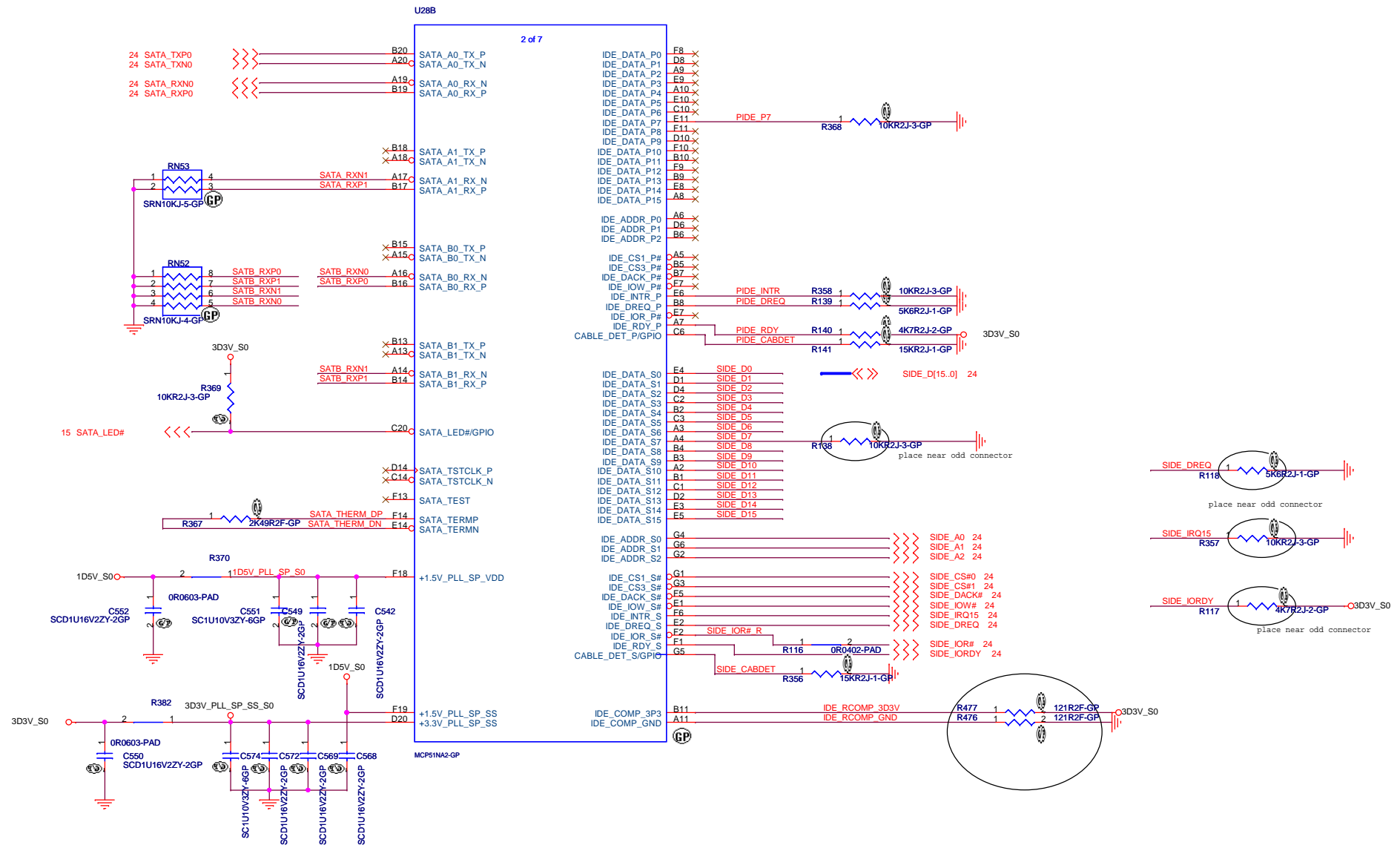

<Variant Name>

緯創資通 Wistron Corporation
21F, 88, Sec. 1, Hsin Tai Wu Rd., Hsichih, Taipei Hsien 221, Taiwan, R.O.C.

Title: **MCP51(3/6)SATA/PATA**

Size	Document Number	Rev
A3	SHIBA	SA

Date: Monday, February 20, 2006 Sheet 19 of 44

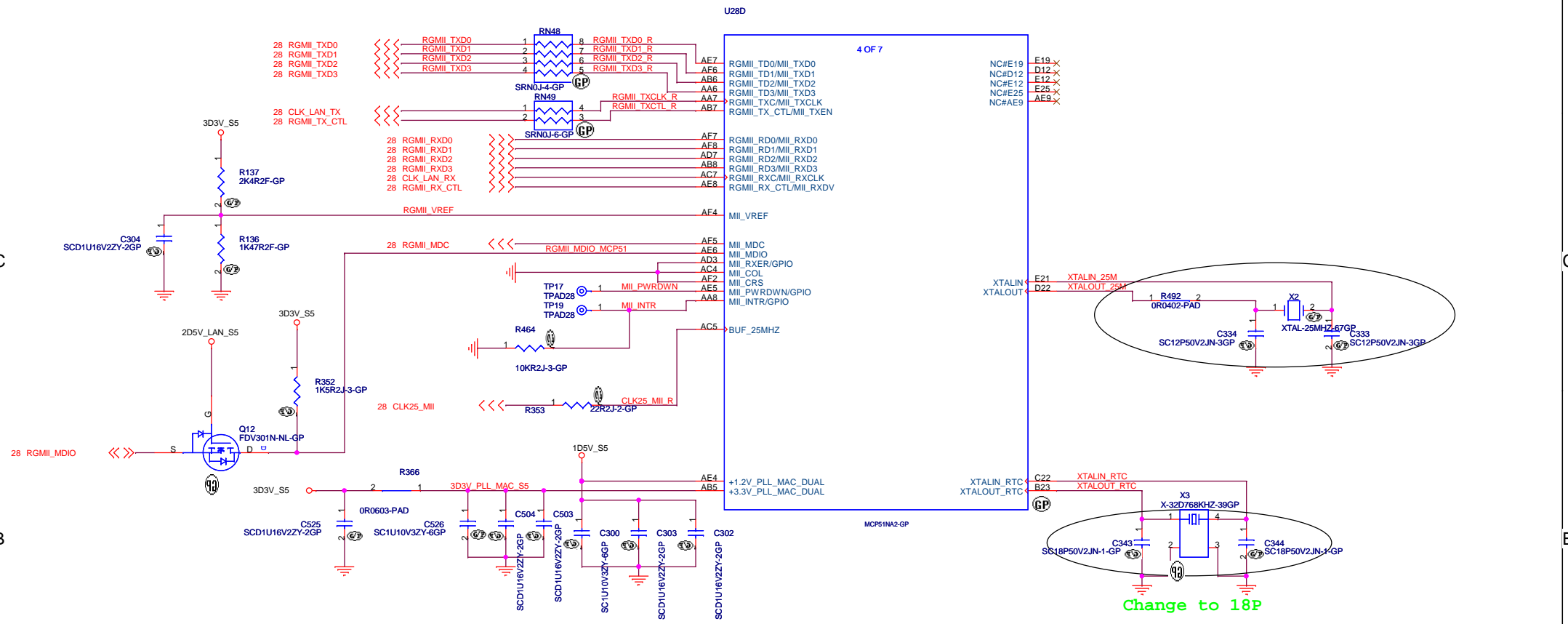

<Variant Name>

緯創資通		Wistron Corporation	
		21F, 88, Sec. 1, Hsin Tai Wu Rd., Hsichih, Taipei Hsien 221, Taiwan, R.O.C.	
Title			
MCP51(5/6)RGMII			
Size		Document Number	
A3		SHIBA	
Date: Monday, February 20, 2006		Rev	
		SB	
		Sheet 21 of 44	

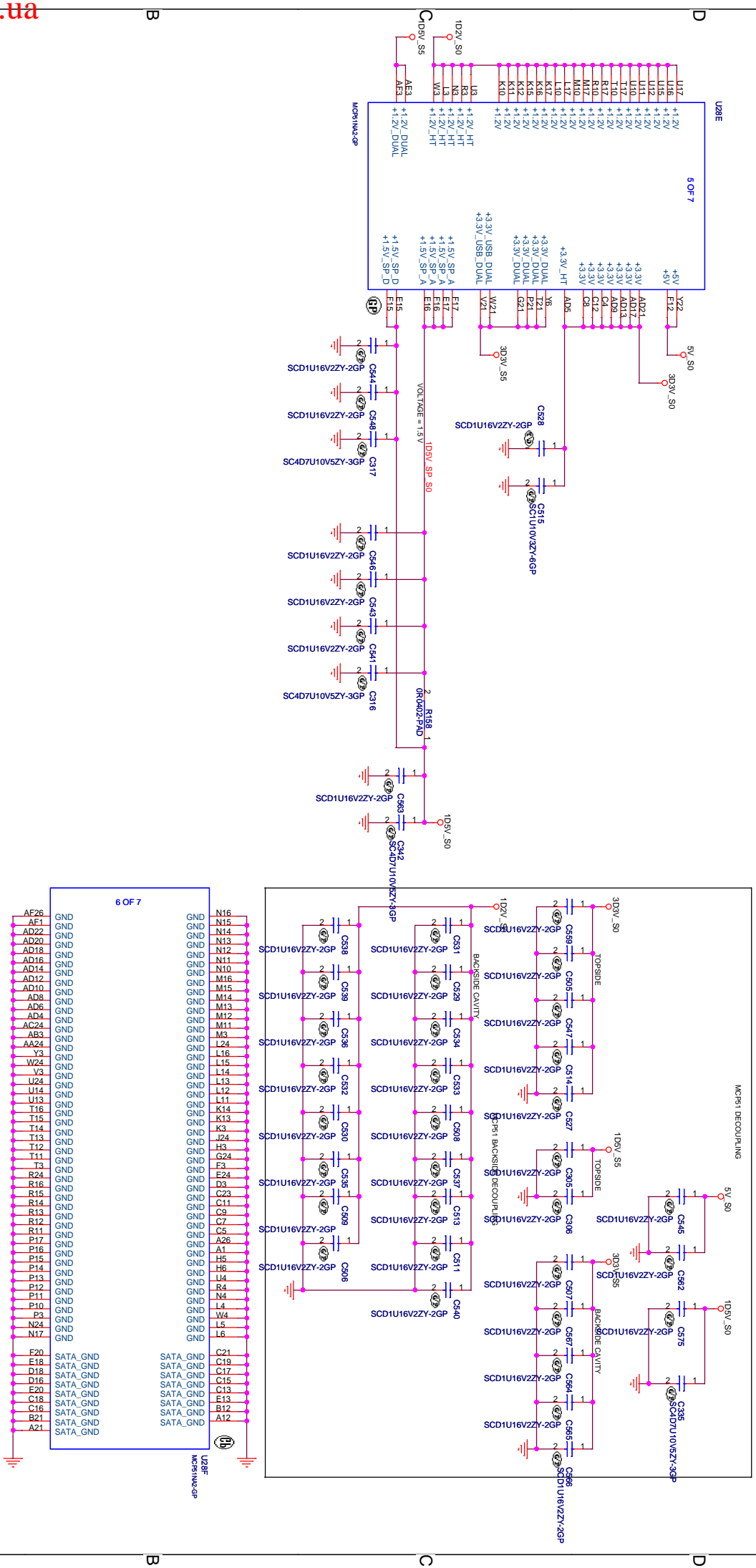

<Variant Names>

Title	MCP51(6)POWER
Doc Number	SHIBA
Rev	SB

Wistron Corporation
 2/F, 88, Sec. 1, Hsin Tai Wu Rd., Hsichm, Taipei, Taiwan, Z.I., Taiwan, R.O.C.

Sheet 22 of 44

SATA HD Connector

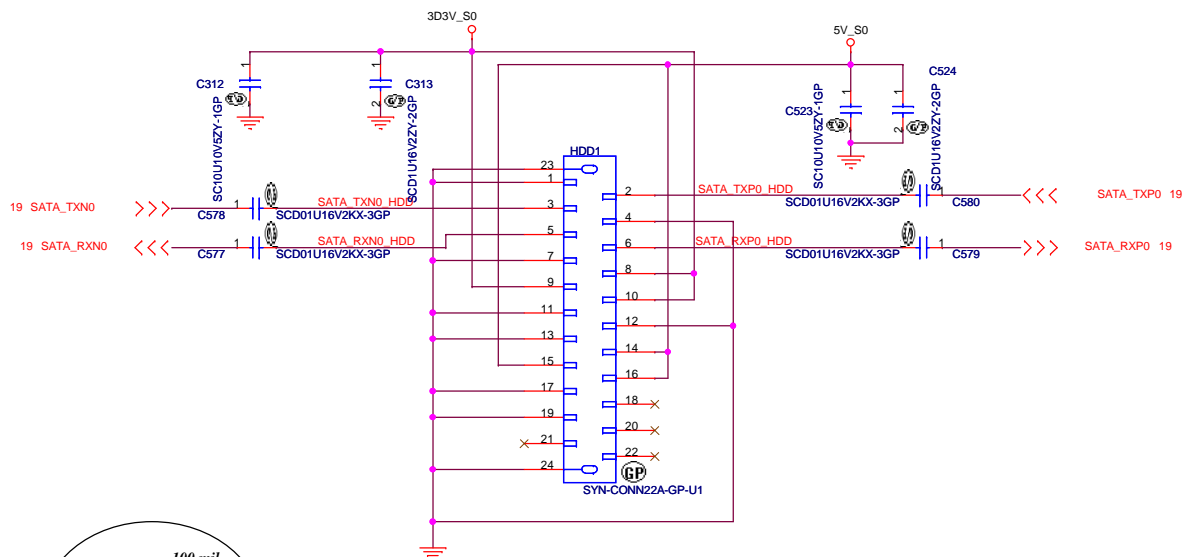

CD-ROM CONNECTOR

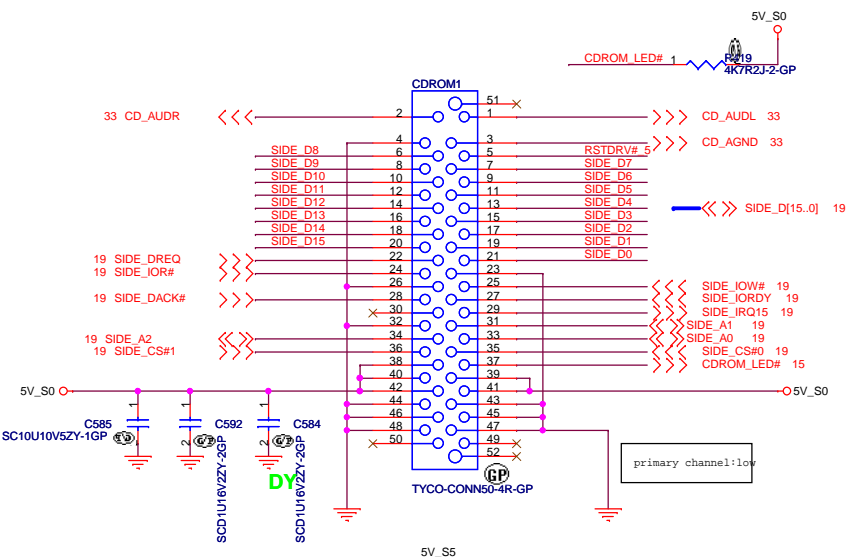

USB PORT

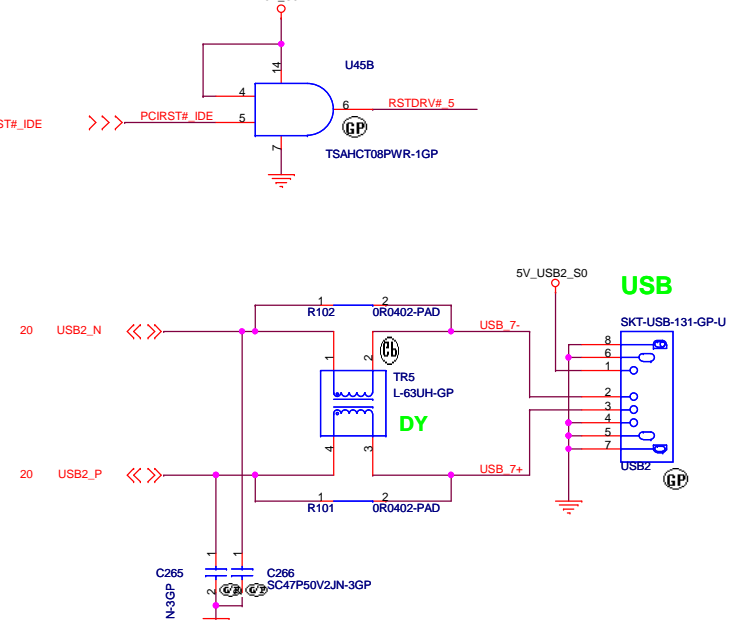
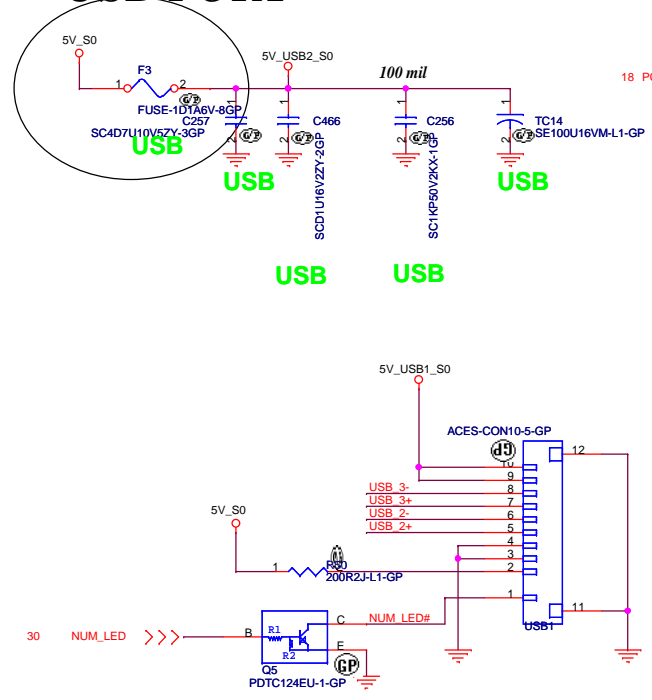
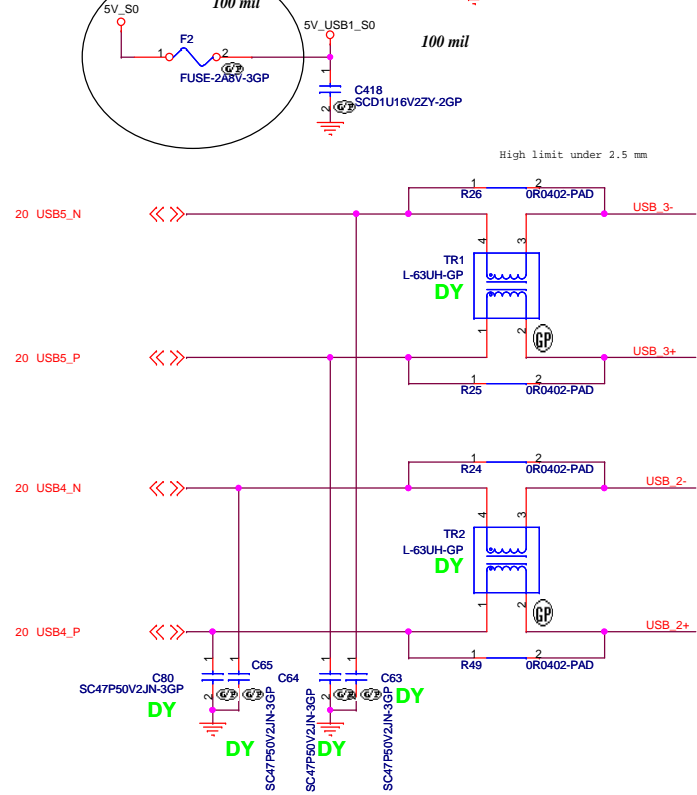

緯創資通 Wistron Corporation 21F, 88, Sec. 1, Hsin Tai Wu Rd., Hsichih, Taipei Hsien 221, Taiwan, R.O.C.			
Title HD/CDROM			
Size A3	Document Number SHIBA		Rev SA
Date: Saturday, March 04, 2006	Sheet 24	of 44	

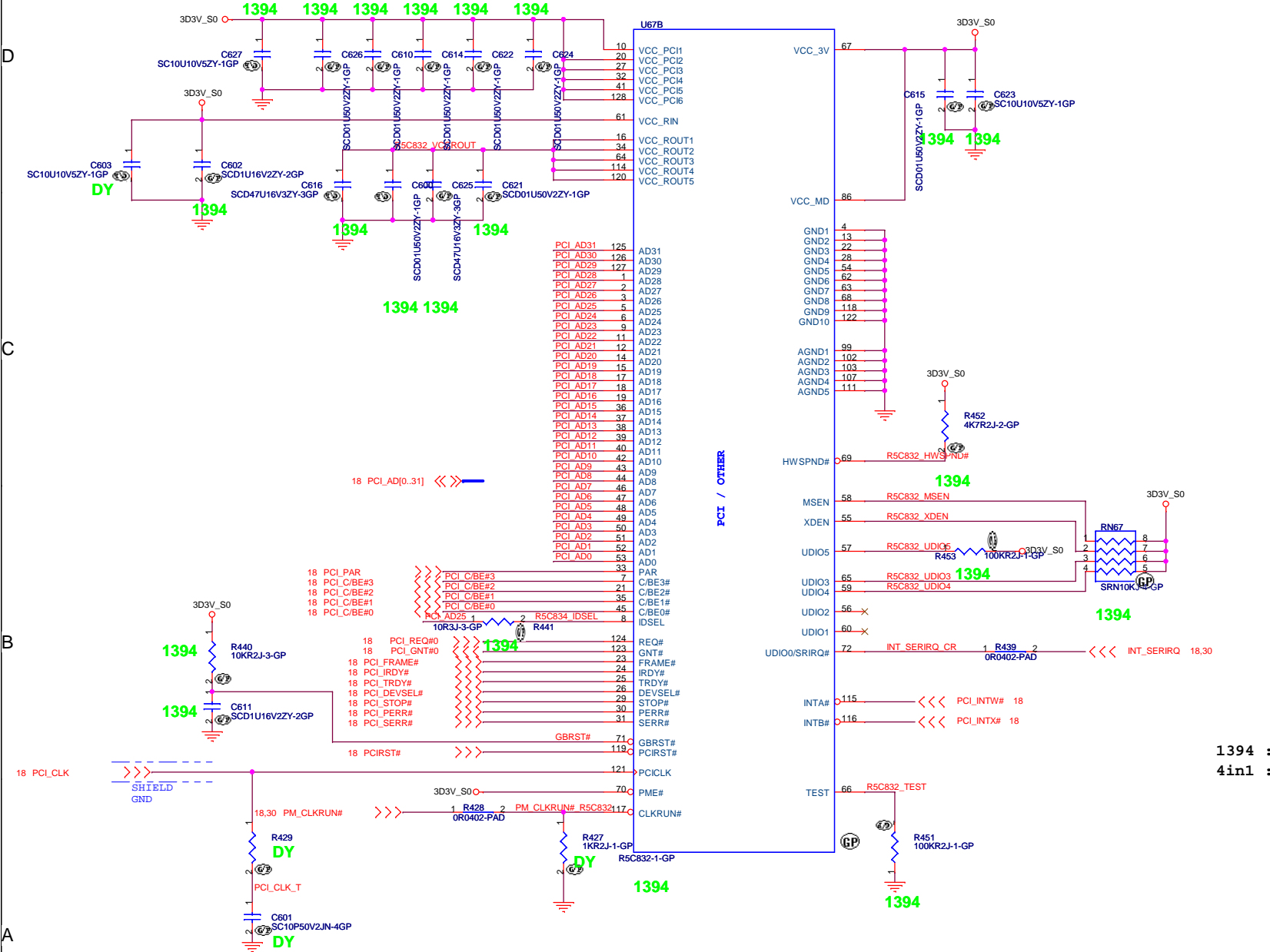

1394 : INTA#
 4in1 : INTB#

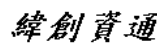
 Wistron Corporation 21F, 88, Sec.1, Hsin Tai Wu Rd., Hsichih, Taipei Hsien 221, Taiwan, R.O.C.		
Title R5C832/PCI		
Size A3	Document Number SHIBA	Rev SA
Date: Monday, February 20, 2006	Sheet 25	of 44

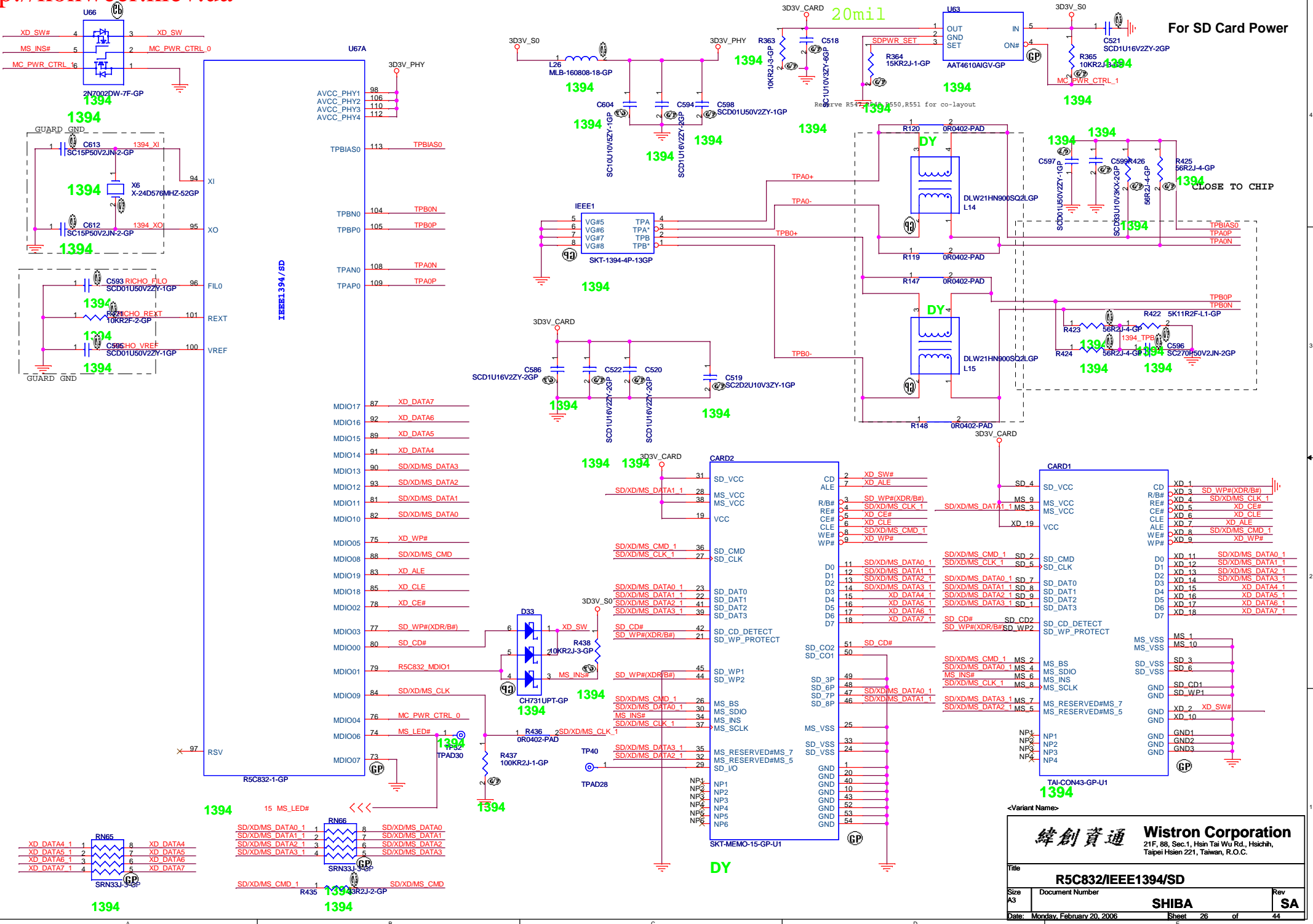

緯創資通 **Wistron Corporation**
 21F, 88, Sec.1, Hsin Tai Wu Rd., Hsichih, Taipei Hsien 221, Taiwan, R.O.C.

Title: **R5C832/IEEE1394/SD**

Size: A3 Document Number: **SHIBA** Rev: **SA**

Date: Monday, February 20, 2006 Sheet 26 of 44

Mini Card Connector

Mini Card Connector 1

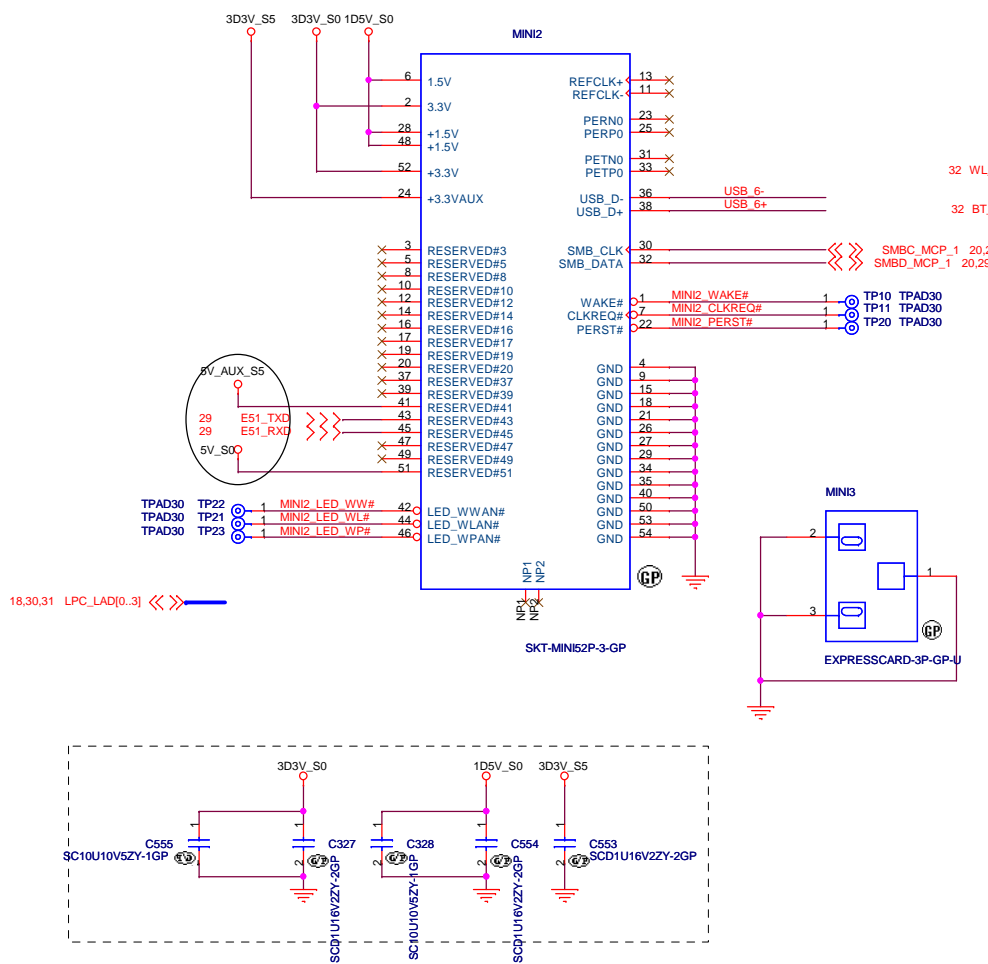

Mini Card Connector 2

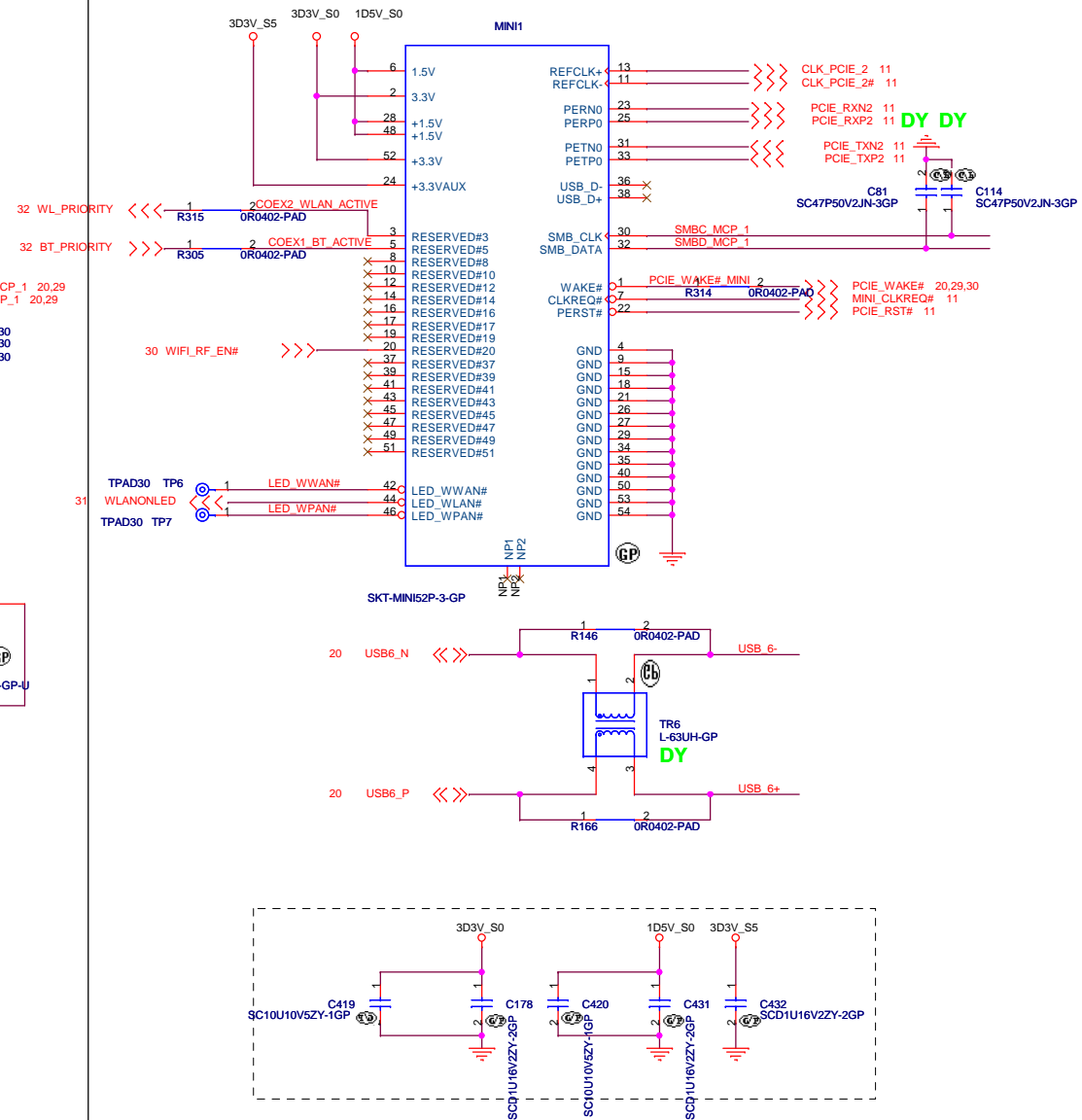

1. PHY address:00001
2. ENA_XC:Enable Auto-Crossover
3. RGMII_TX:Transmit clock not internally delayed
4. RGMII_RX:Receive clock transition when data transitions
5. Advertise all capabilities

E1116 use external 2.5V single power supply.
1.8V create by PNP and 1.2V use internal reg.

Put L10 for E3016 application since pin 28
NOB for E1116

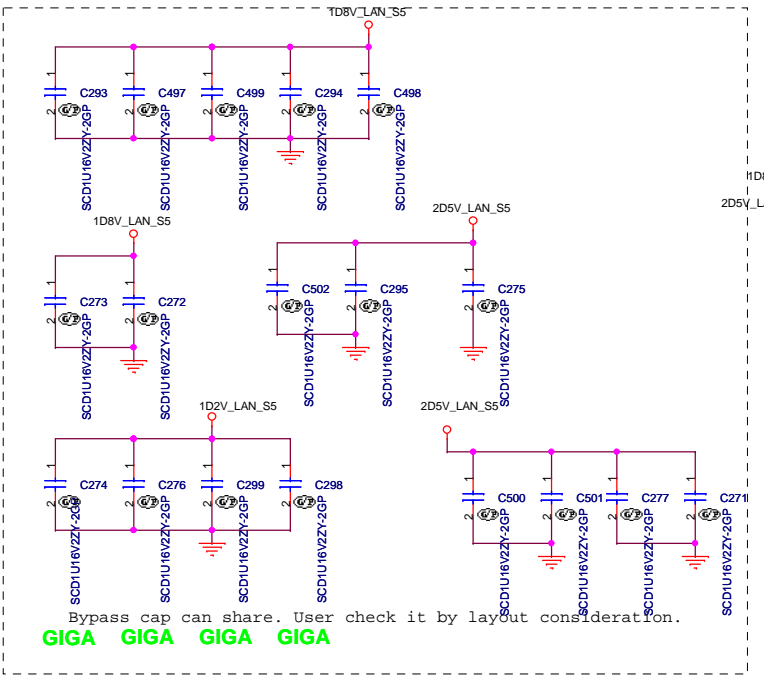
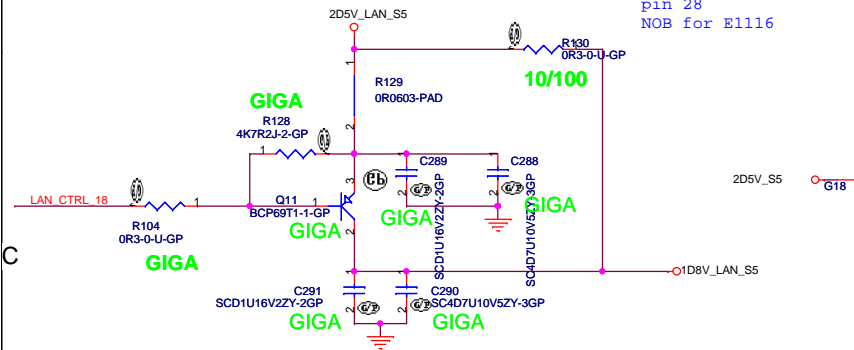

Bypass cap can share. User check it by layout consideration.

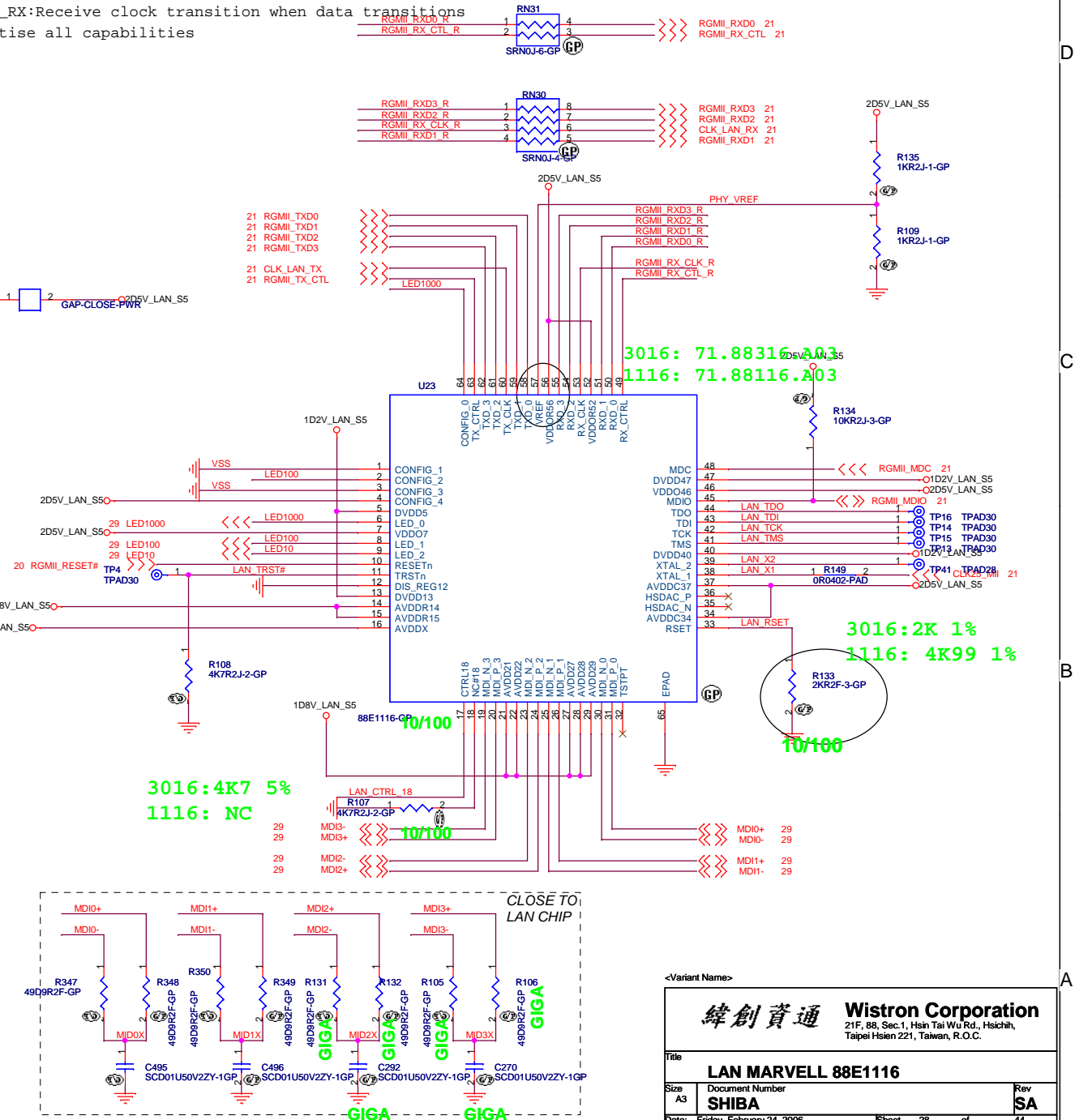

3016: 4K7 5%
1116: NC

3016: 71.88316.A03
1116: 71.88116.A03

3016: 2K 1%
1116: 4K99 1%

10/100

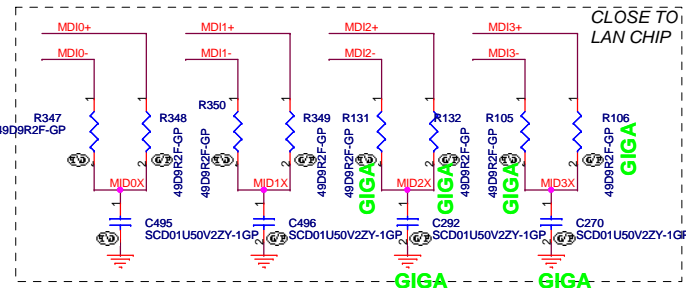

CLOSE TO LAN CHIP

<Variant Name>

緯創資通 Wistron Corporation
21F, 88, Sec.1, Hsin Tai Wu Rd., Hsinshih, Taipei Hsien 221, Taiwan, R.O.C.

Title: **LAN MARVELL 88E1116**

Size A3	Document Number: SHIBA	Rev: SA
Date: Friday, February 24, 2006	Sheet: 28	of 44

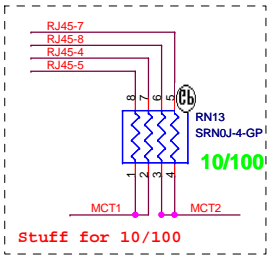
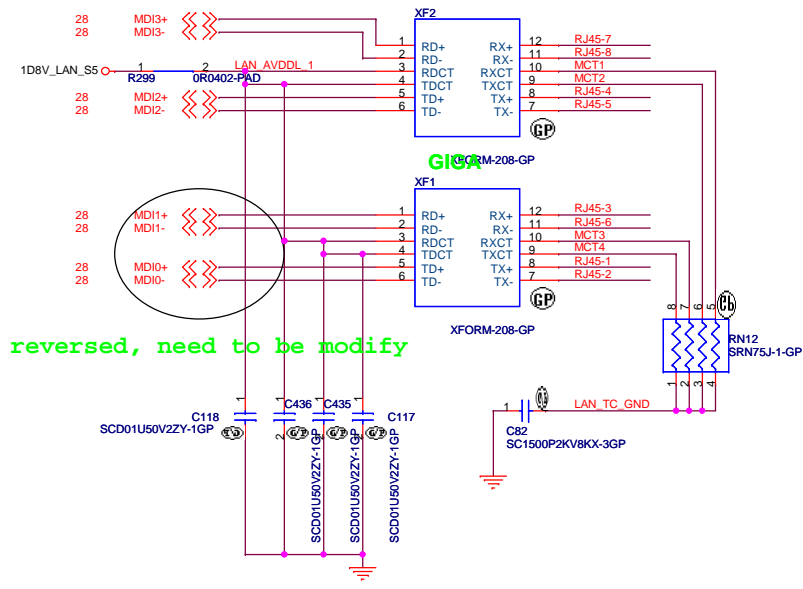

- 1.route on bottom as differential pairs.
- 2.Tx+/Tx- are pairs. Rx+/Rx- are pairs.
- 3.No vias, No 90 degree bends.
- 4.pairs must be equal lengths.
- 5.6mil trace width, 12mil separation.
- 6.36mil between pairs and any other trace.
- 7.Must not cross ground moat, except RJ-45 moat.

GREEN: LINK 10/100 Mbps
YELLOW: TX/RX ACTIVITY
ORANGE: LINK 1000Mbps

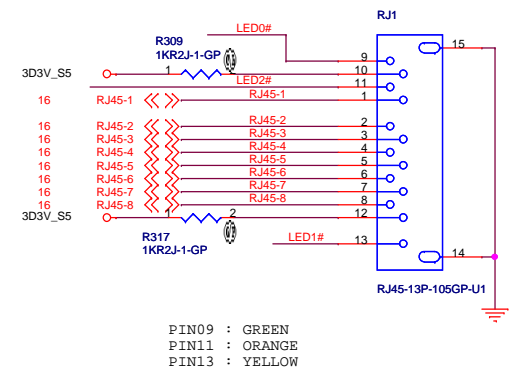
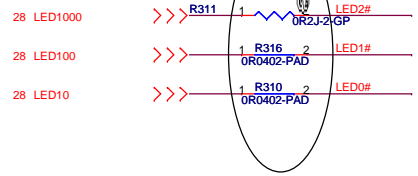

NEWCARD Connector

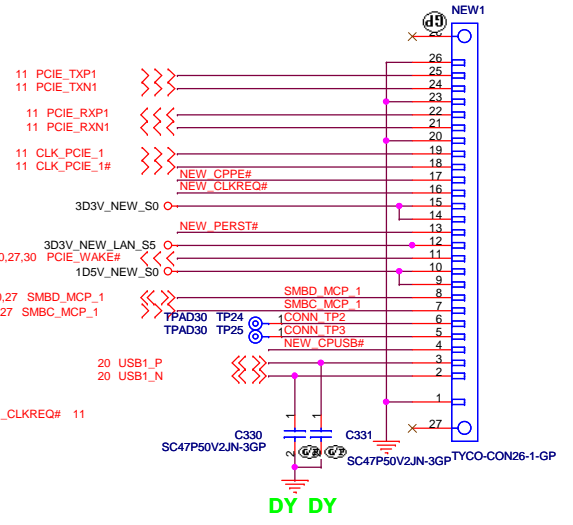
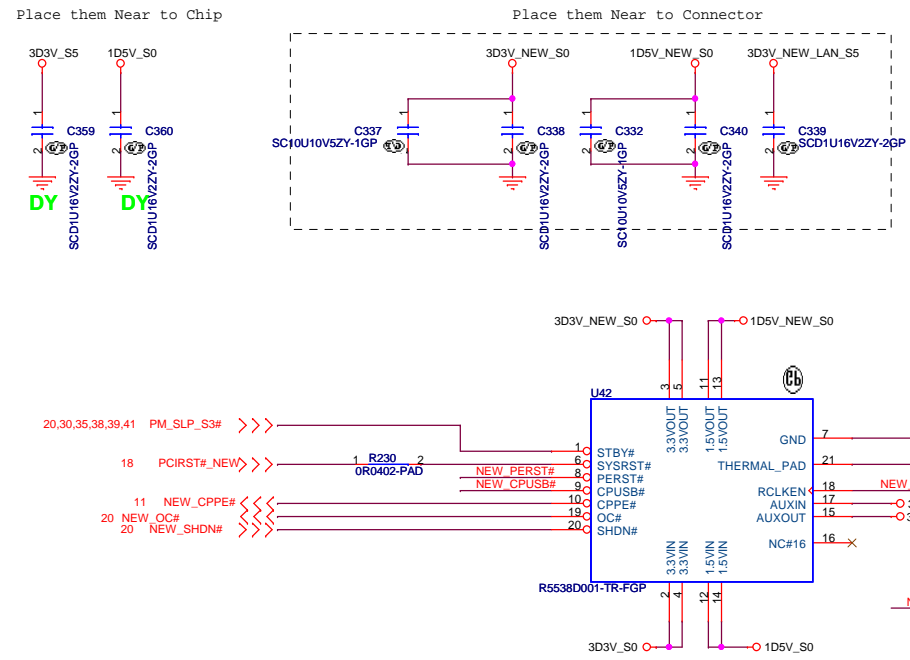

緯創資通 Wistron Corporation
21F, 88, Sec.1, Hsin Tai Wu Rd., Hsichih, Taipei Hsien 221, Taiwan, R.O.C.

Title: **New Card**

Size: A3
Document Number: **SHIBA**
Rev: **SA**

Date: Monday, February 20, 2006
Sheet: 29 of 44

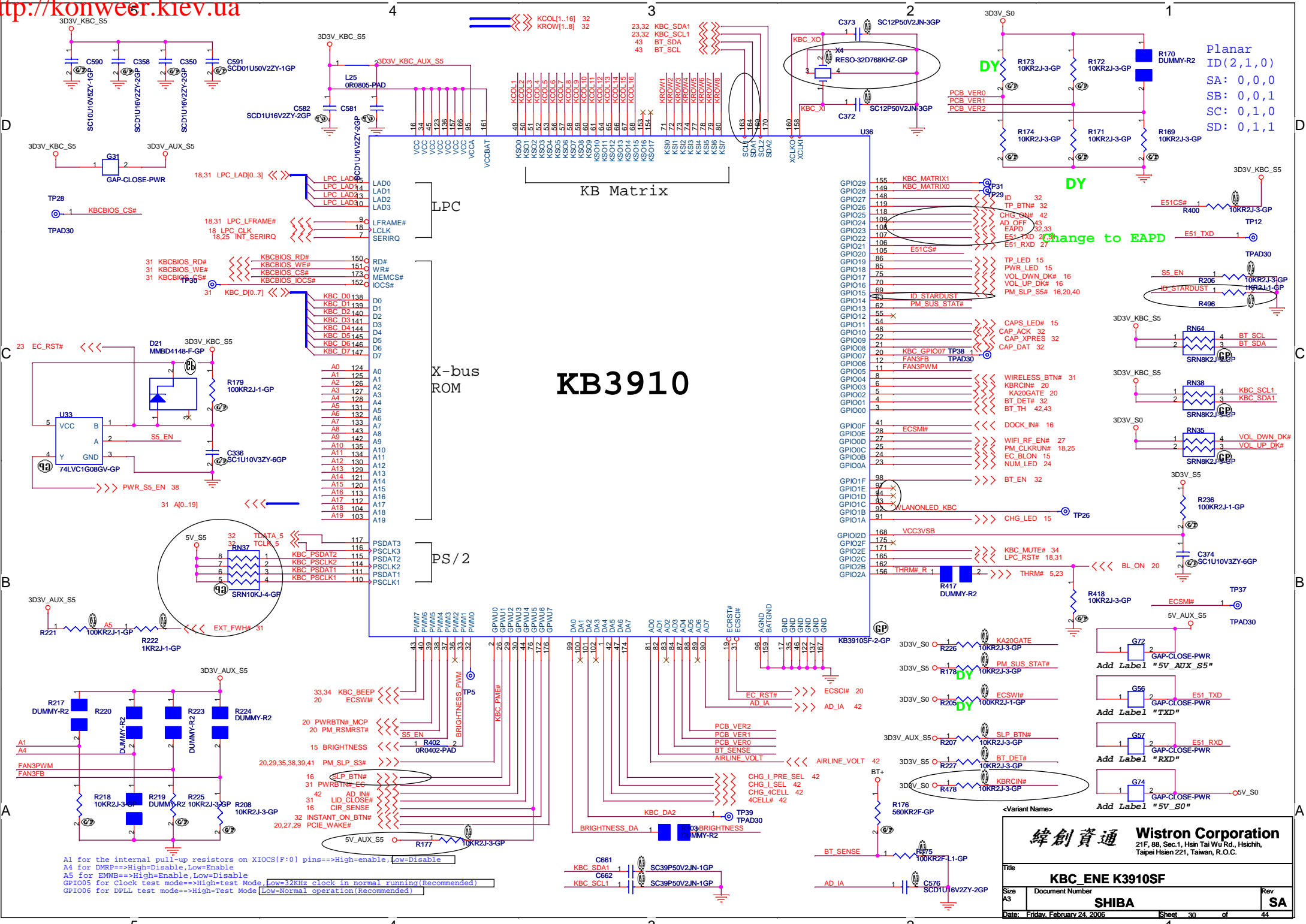

Planar
ID(2,1,0)
SA: 0,0,0
SB: 0,0,1
SC: 0,1,0
SD: 0,1,1

KB3910

緯創資通 Wistron Corporation
21F, 88, Sec. 1, Hsin Tai Wu Rd., Hsichih, Taipei Hsien 221, Taiwan, R.O.C.

Title: **KBC_ENE K3910SF**

Size: A3	Document Number: SHIBA	Rev: SA
----------	-------------------------------	----------------

Date: Friday, February 24, 2006 Sheet 30 of 44

A1 for the internal pull-up resistors on XIOCS[!F:0] pins==>High=enable, Low=Disable
 A4 for DMRP==>High=Disable, Low=Enable
 A5 for EMWB==>High=Enable, Low=Disable
 GPIO05 for clock test mode==>High=test Mode, Low=32KHz clock in normal running(Recommended)
 GPIO06 for DPLL test mode==>High=Test Mode [Low=Normal operation(Recommended)]

30 A[0..19]

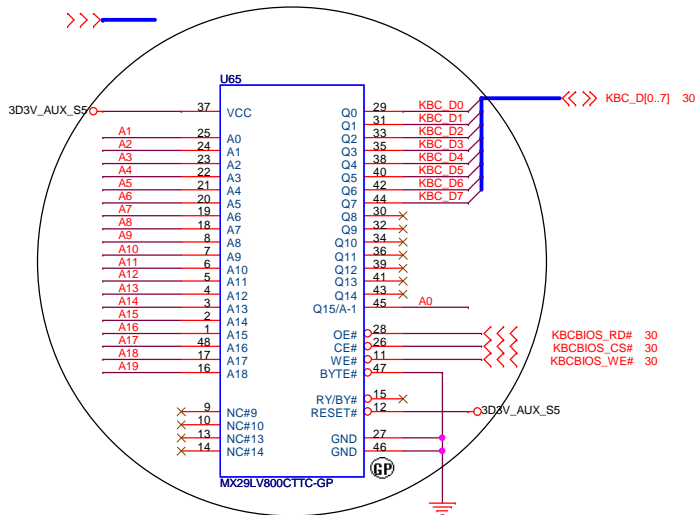

Change to MX29LV800CTTC
72.29800.0B9

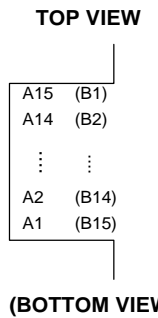

GOLDEN FINGER FOR DEBUG BOARD

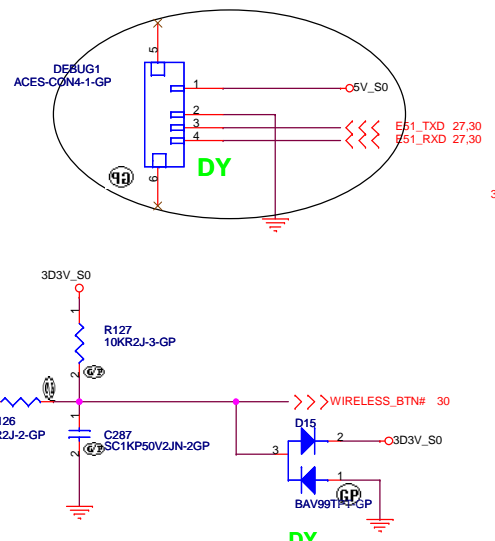
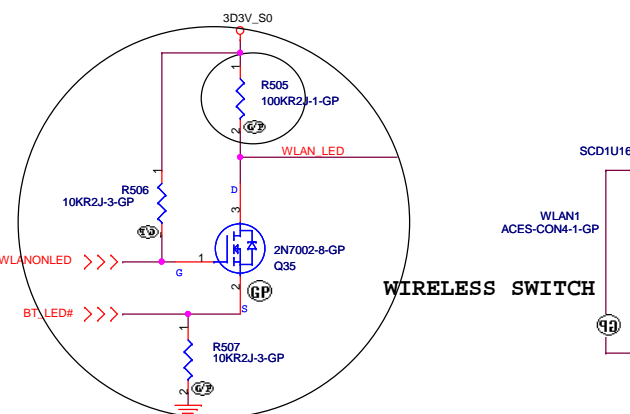
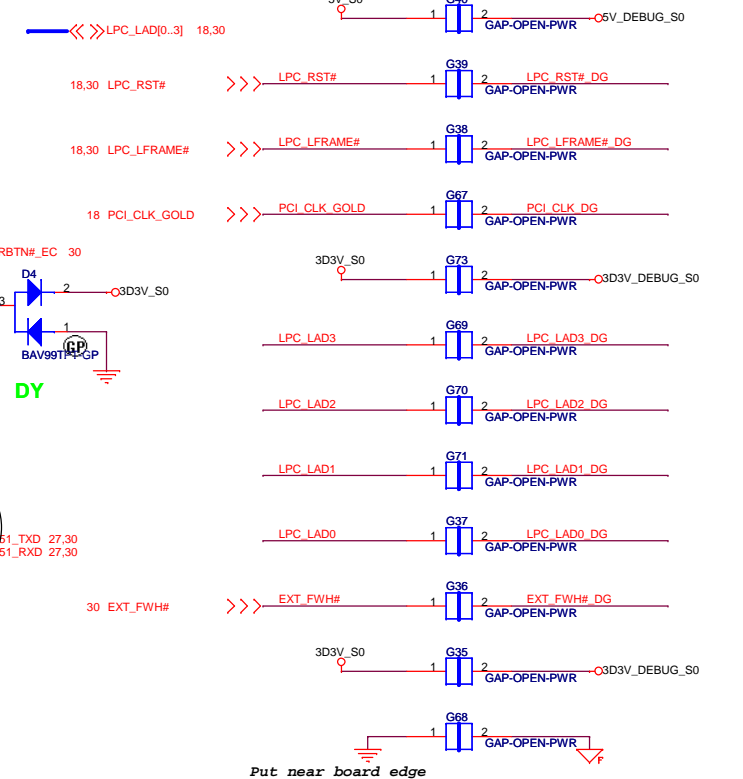
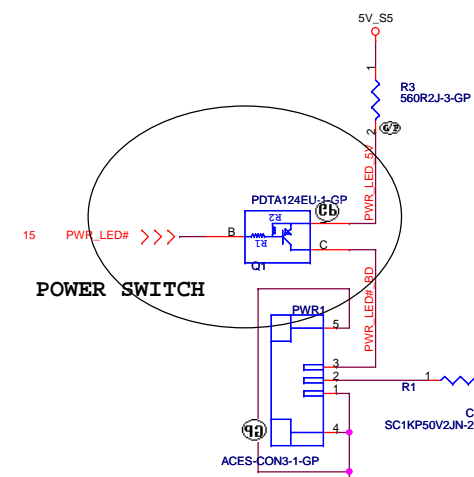
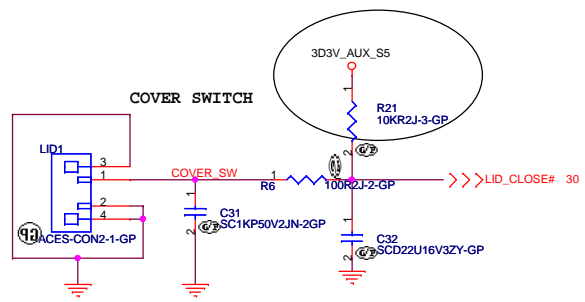
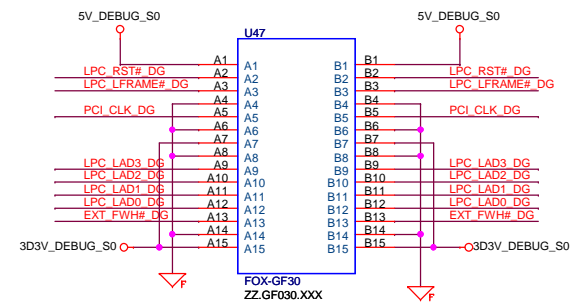

CAMERA

Blue thumb

Internal KeyBoard Connector



Keyboard matrix (from vendor)

	US	Eur	Jap
MATRIXID1#	0	1	0
MATRIXID2#	0	0	1

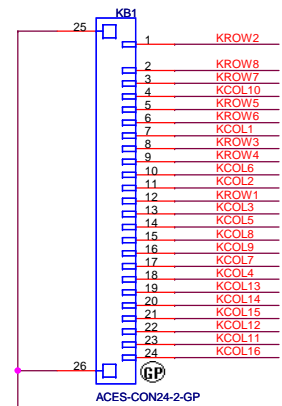

TouchPad Connector

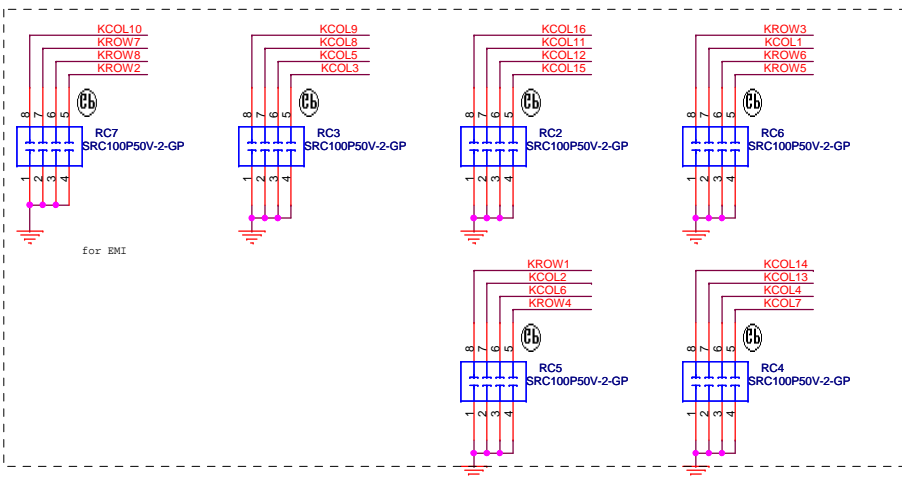
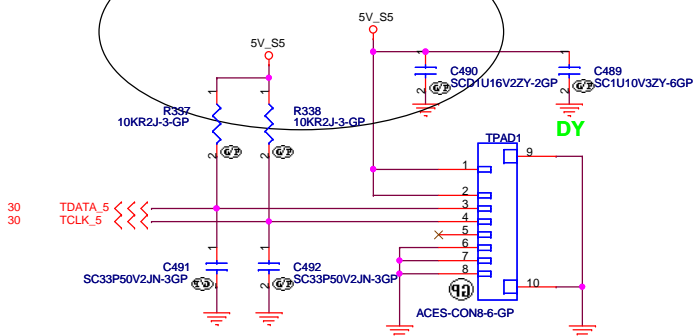

TOUCH-PAD SWITCH

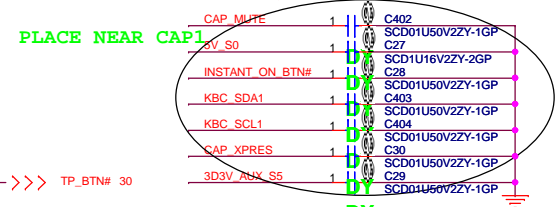
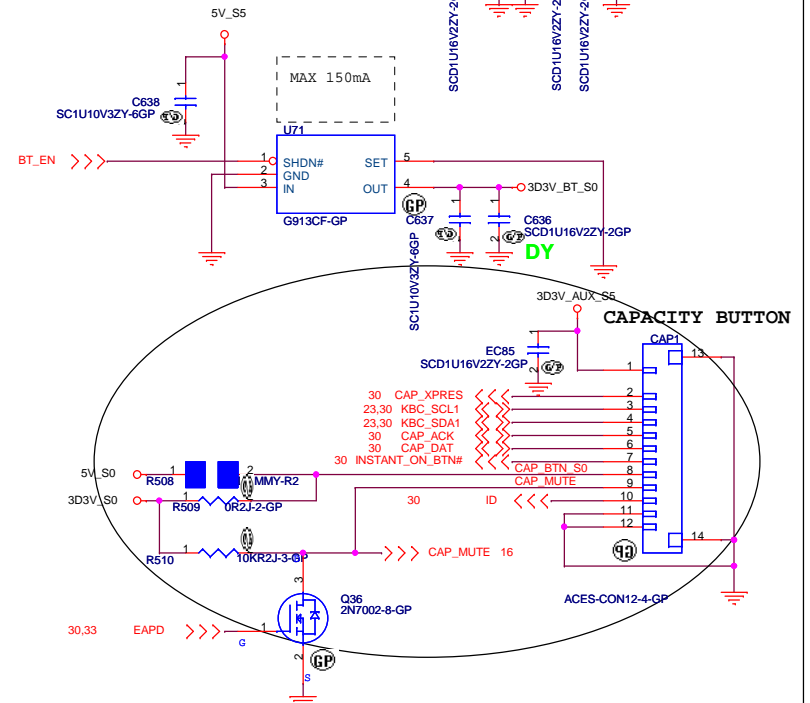
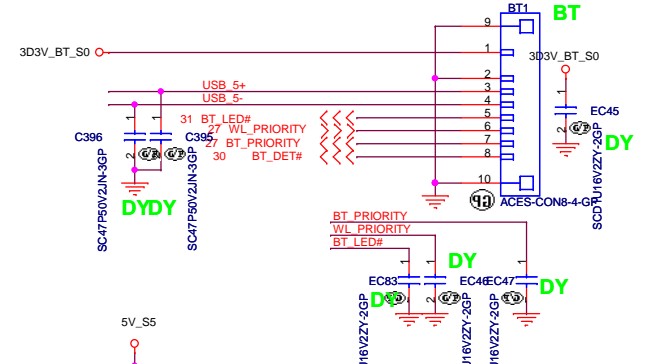
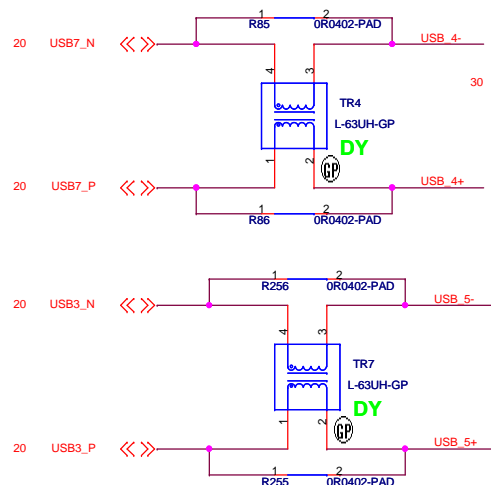
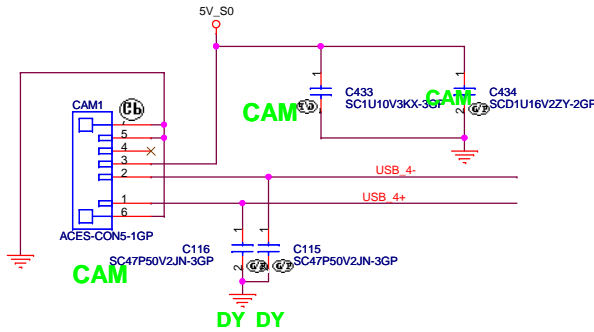
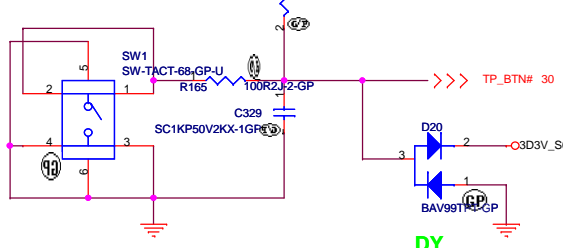

緯創資通 Wistron Corporation
 21F, 88, Sec.1, Hsin Tai Wu Rd., Hsichih, Taipei Hsien 221, Taiwan, R.O.C.

Title: **KeyBoard-CONN**

Size A3	Document Number	Rev SA
SHIBA		

Date: Sunday, February 26, 2006 Sheet 32 of 44

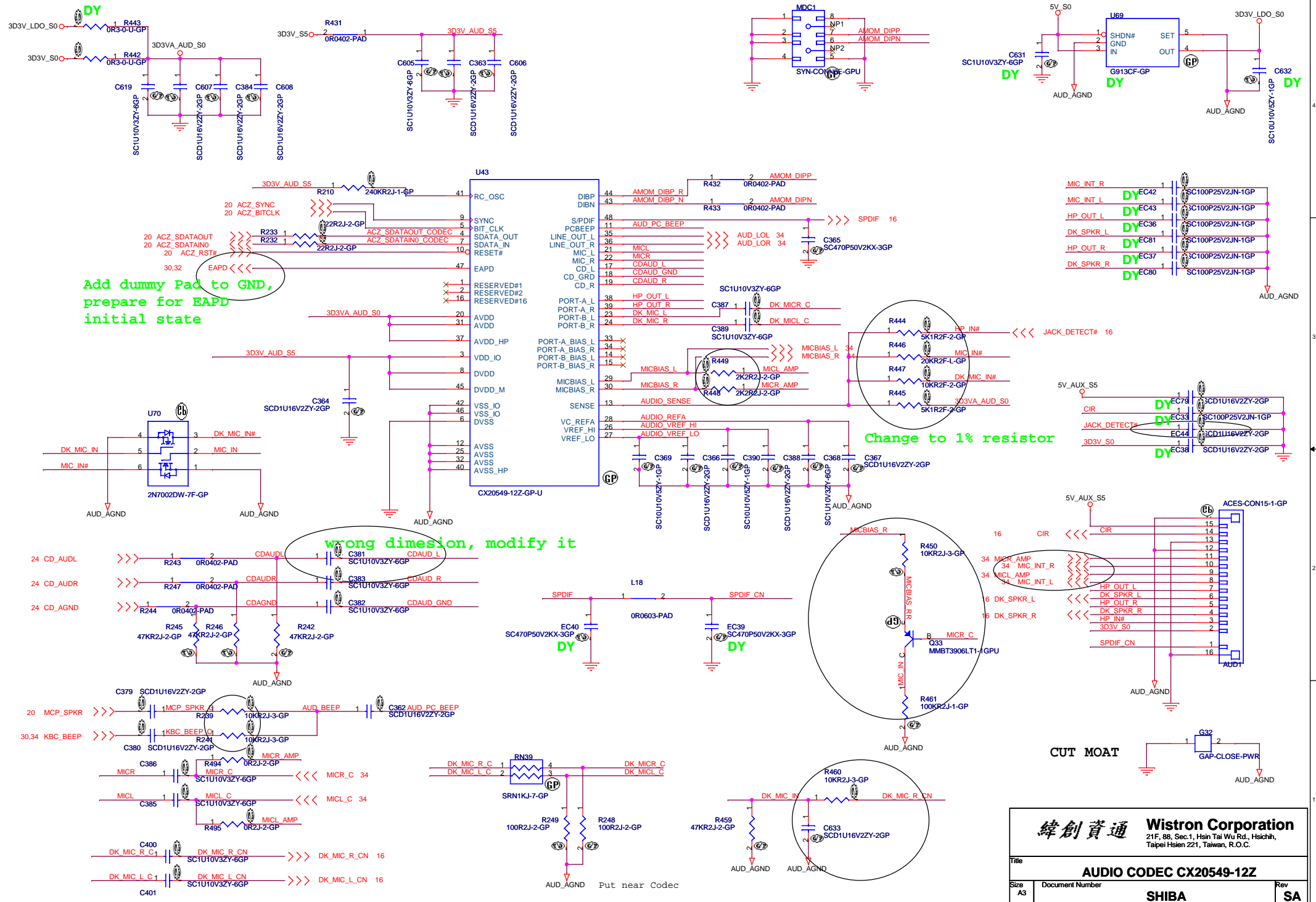

緯創資通		Wistron Corporation	
		21F, 88, Sec.1, Hsin Tai Wu Rd., Hsichih, Taipei Hsien 221, Taiwan, R.O.C.	
AUDIO CODEC CX20549-12Z			
Title	Document Number	Rev	SA
A3		SHIBA	
Date: Friday, February 24, 2006	Sheet	33	of 44

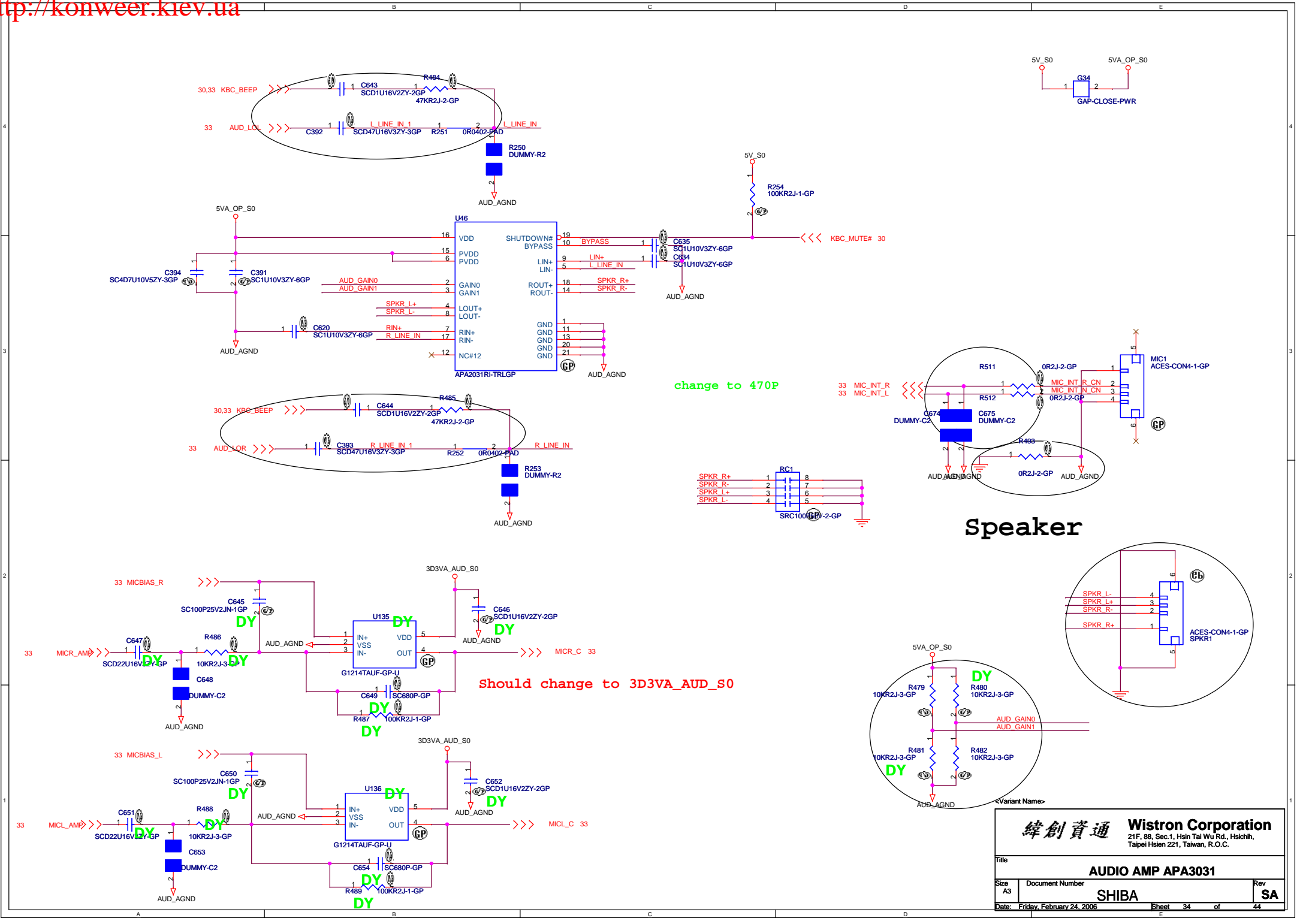

Suspend Power

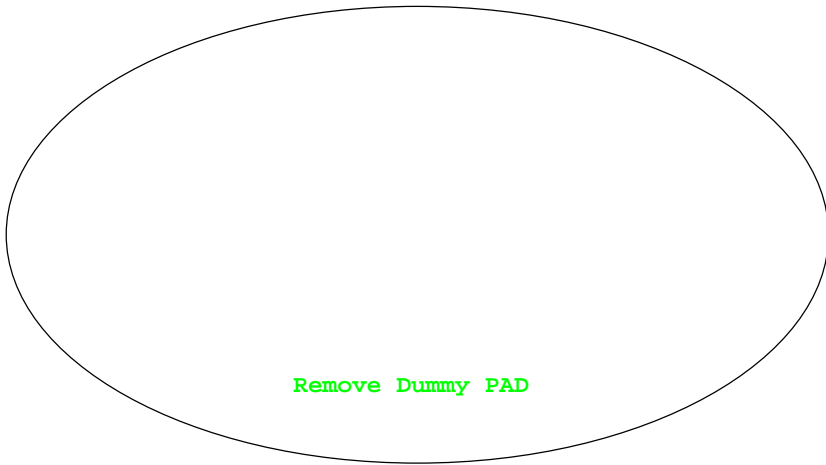

Run Power

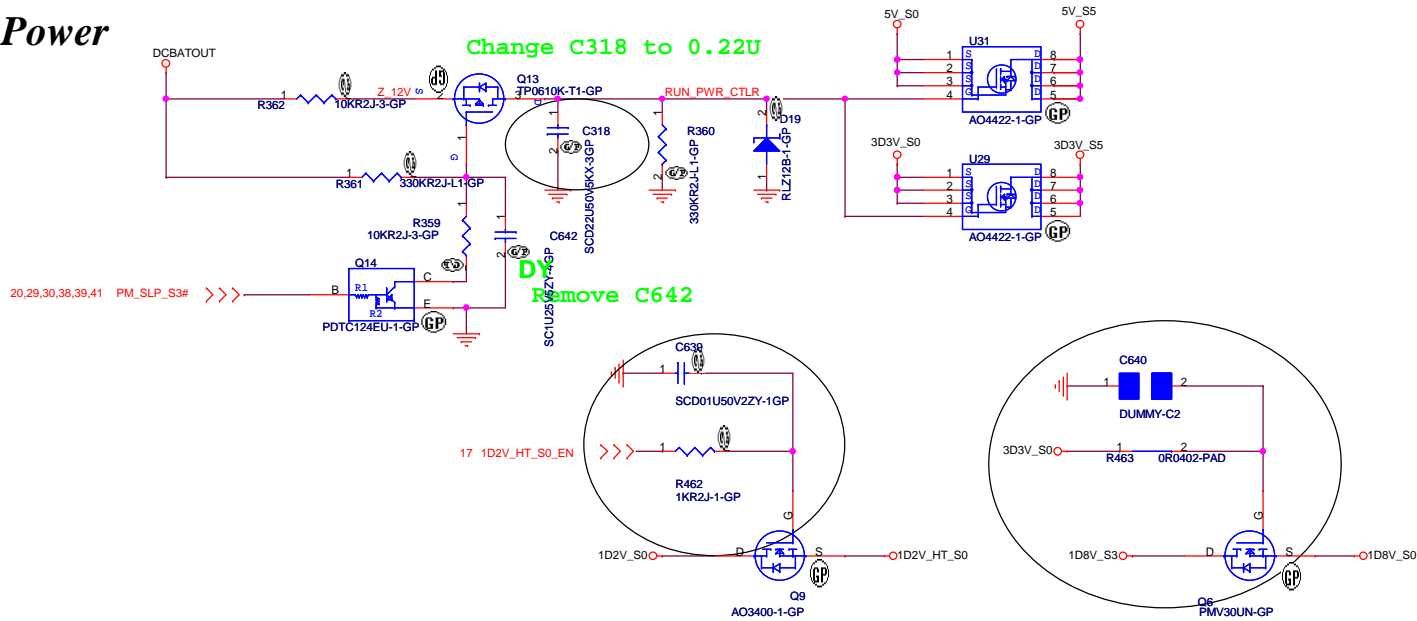

CPU_VCORE

VID=1.20V(25W)/1.35V(35W)

Iomax=21A(25W)/27A(35W)

OCP=40A~45A

TON: Frequency:
GND 550KHz
REF 300KHz
OPEN 200KHz
VCC 100KHz

TABLE 1. VOLTAGE IDENTIFICATION CODES

VID4	VID3	VID2	VID1	VID0	DAC
0	0	0	0	0	1.550
0	0	0	0	1	1.525
0	0	0	1	0	1.500
0	0	0	1	1	1.475
0	0	1	0	0	1.450
0	0	1	0	1	1.425
0	0	1	1	0	1.400
0	0	1	1	1	1.375
0	1	0	0	0	1.350
0	1	0	0	1	1.325
0	1	0	1	0	1.300
0	1	0	1	1	1.275
0	1	1	0	0	1.250
0	1	1	0	1	1.225
0	1	1	1	0	1.200
0	1	1	1	1	1.175
1	0	0	0	0	1.150
1	0	0	0	1	1.125
1	0	0	1	0	1.100
1	0	0	1	1	1.075
1	0	1	0	0	1.050
1	0	1	0	1	1.025
1	0	1	1	0	1.000
1	0	1	1	1	0.975
1	1	0	0	0	0.950
1	1	0	0	1	0.925
1	1	0	1	0	0.900
1	1	0	1	1	0.875
1	1	1	0	0	0.850
1	1	1	0	1	0.825
1	1	1	1	0	0.800
1	1	1	1	1	Shutdown

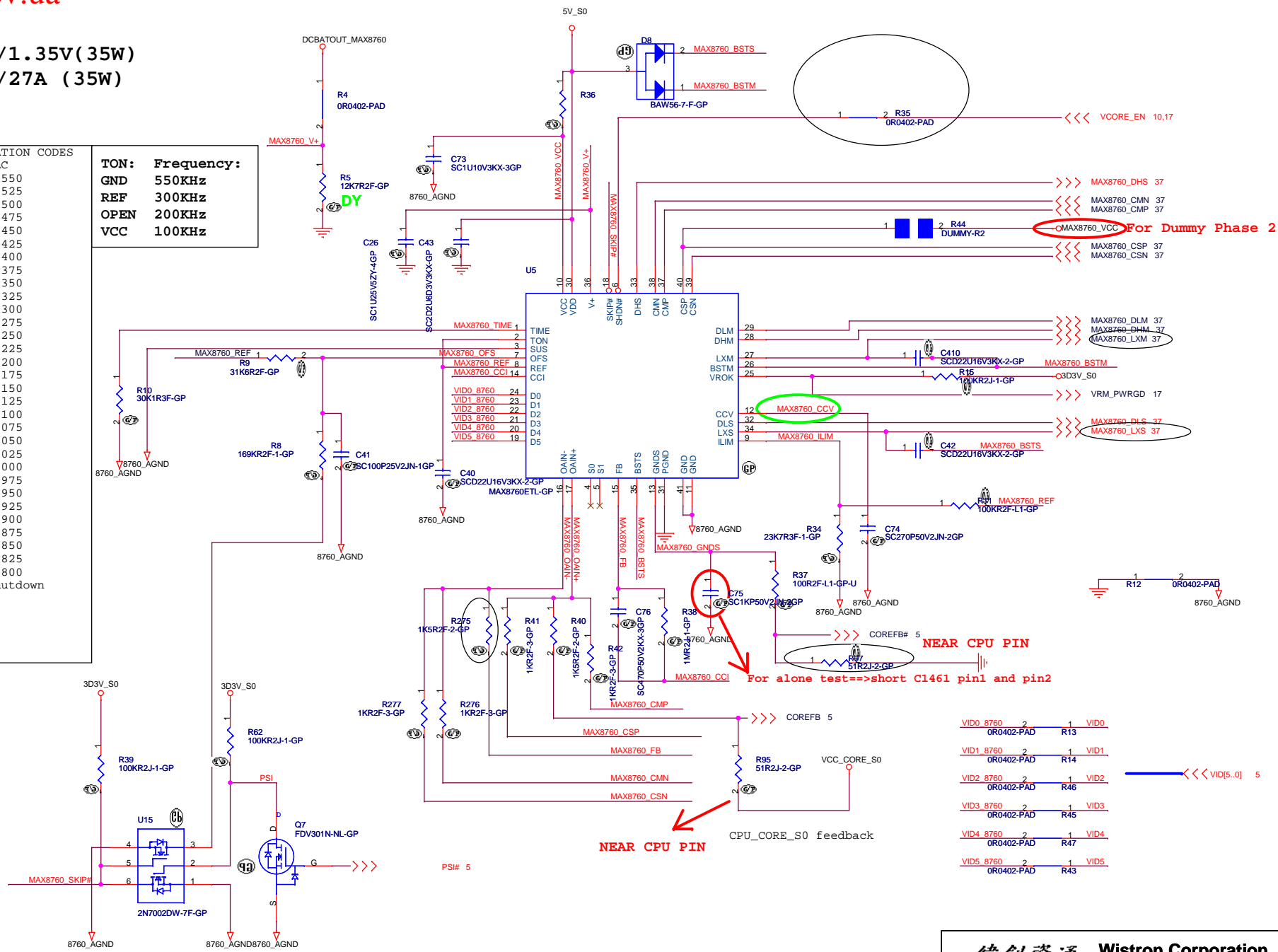

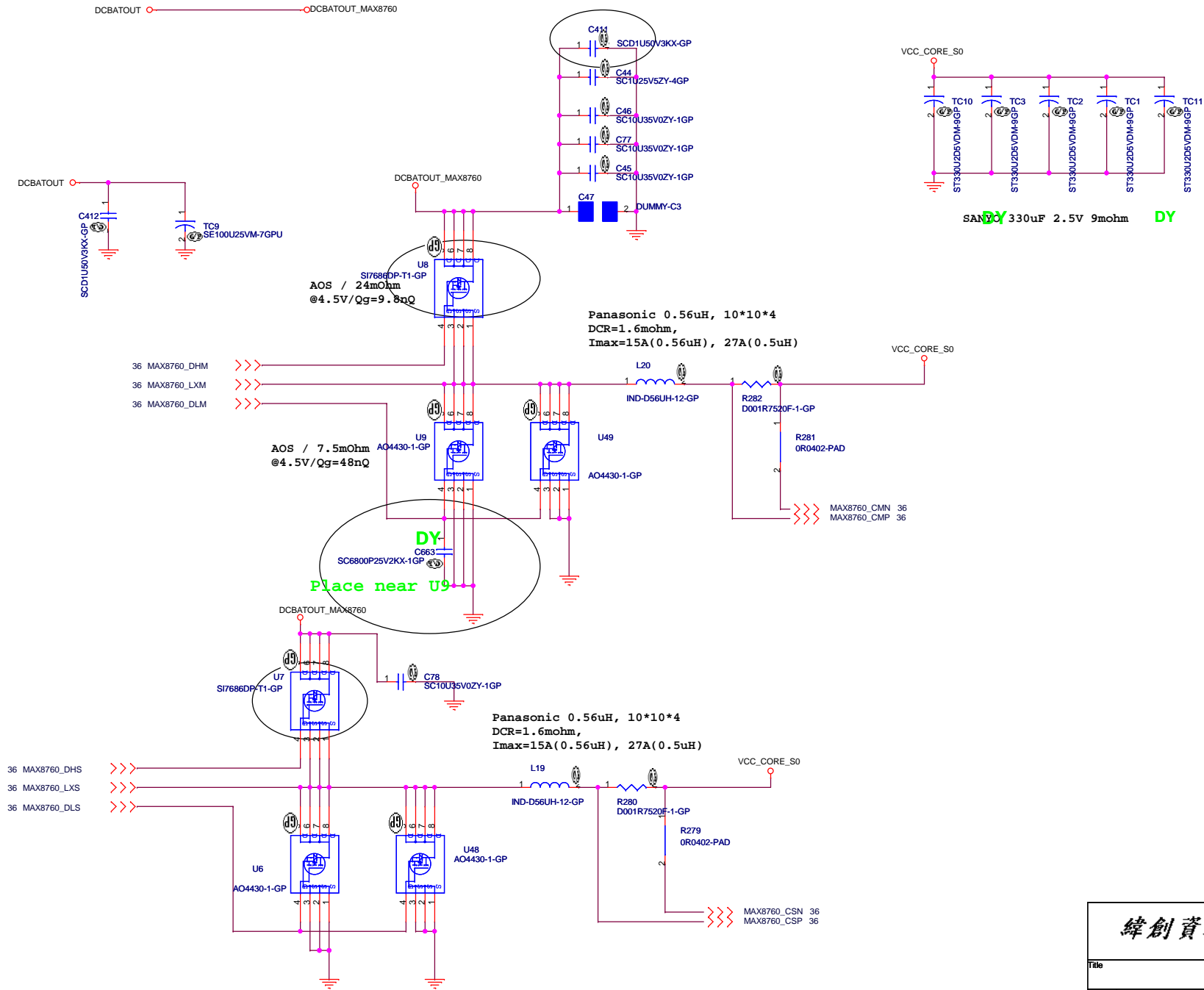

(Power Team)

緯創資通		Wistron Corporation	
		21F, 88, Sec.1, Hsin Tai Wu Rd., Hsichih, Taipei Hsien 221, Taiwan, R.O.C.	
CPU CORE MAX8760(2/2)			
File	Document Number		Rev
Size	SHIBA		SA
Date: Wednesday, February 22, 2006	Sheet	37 of	44

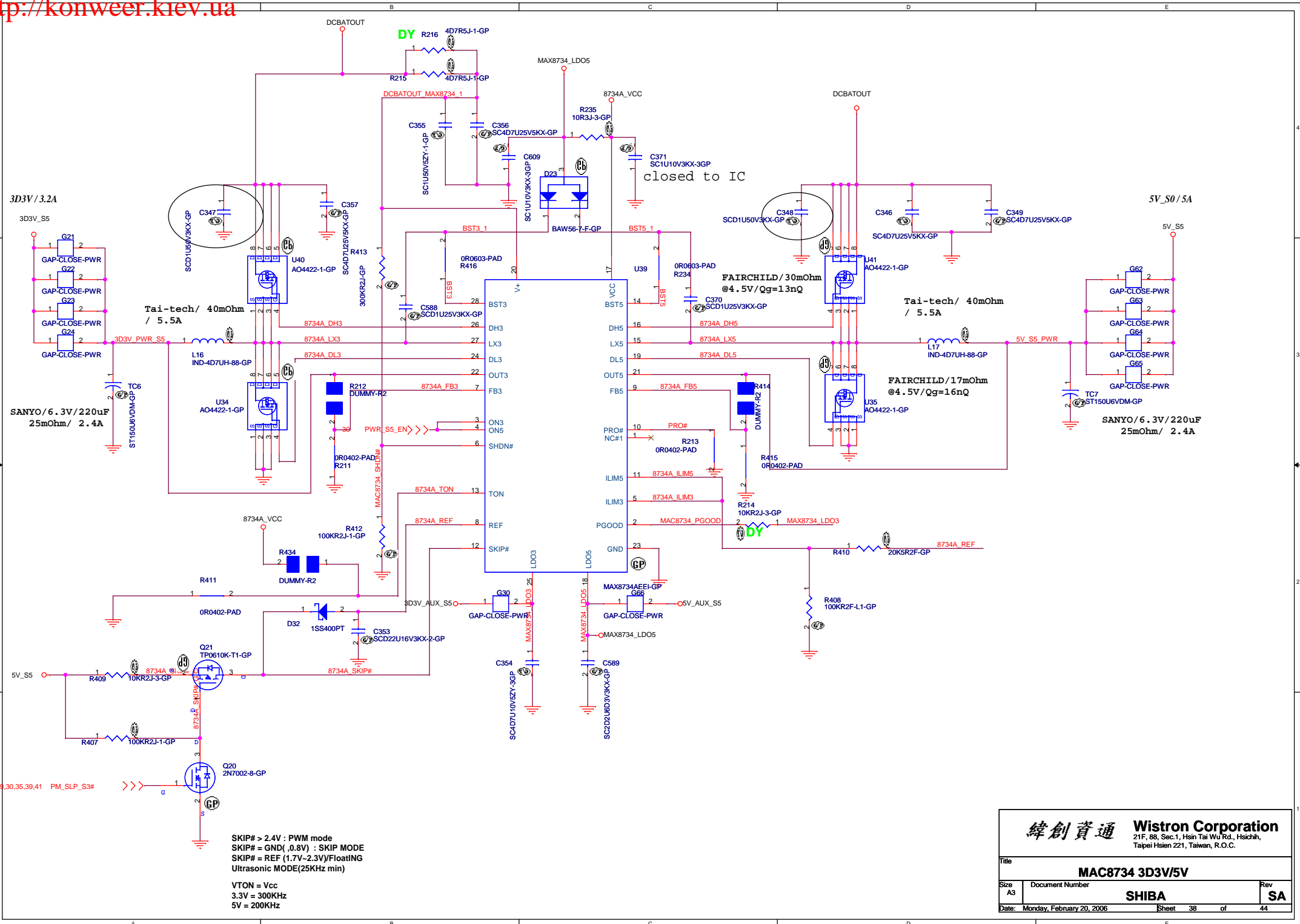

緯創資通 Wistron Corporation		
21F, 88, Sec.1, Hsin Tai Wu Rd., Hsichih, Taipei Hsien 221, Taiwan, R.O.C.		
MAC8734 3D3V/5V		
Title	Document Number	
Size	SHIBA	
A3	SA	SA
Date:	Monday, February 20, 2006	Sheet 38 of 44

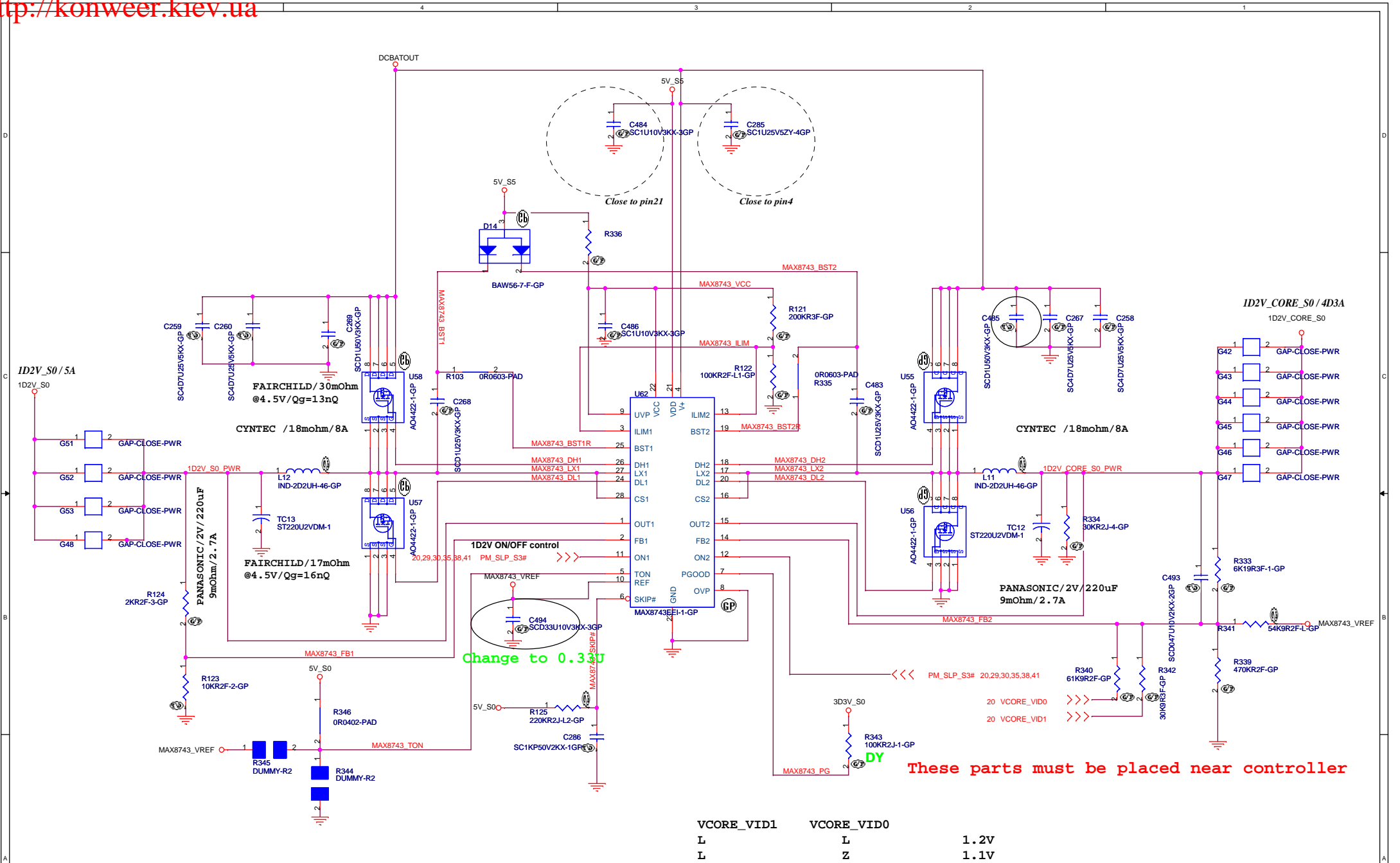

Vcore_Vid1	Vcore_Vid0	
L	L	1.2V
L	Z	1.1V
Z	L	1.0V
Z	Z	Reserved

緯創資通 Wistron Corporation
 21F, 88, Sec.1, Hsin Tai Wu Rd., Hsichih, Taipei Hsien 221, Taiwan, R.O.C.

Title: **MAX8743 1D2V/1D2V_CORE**

Size A3	Document Number	Rev
	SHIBA	SA

Date: Monday, February 20, 2006 Sheet 39 of 44

TI TPS51116 for 1D8V and 0D9V

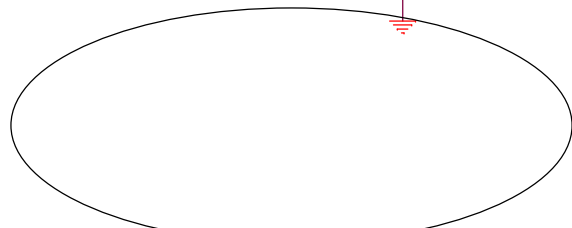
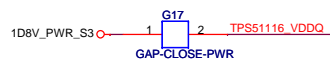
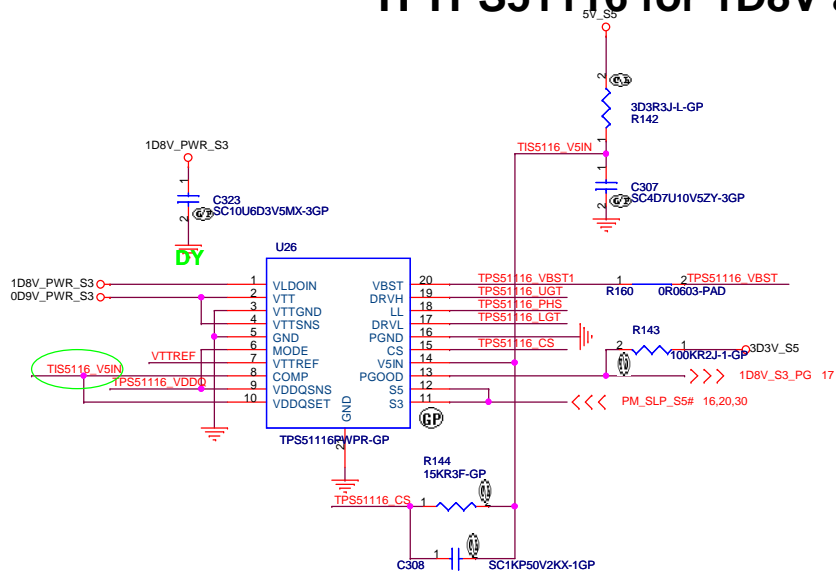

State	S3	S5	VDDR	VTTREF	VTT
S0	Hi	Hi	On	On	On
S3	Lo	Hi	On	On	Off (Hi-Z)
S4/S5	Lo	Lo	Off	Off	Off

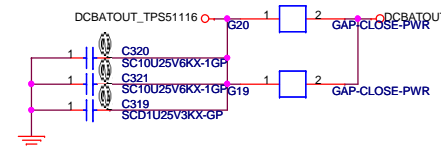
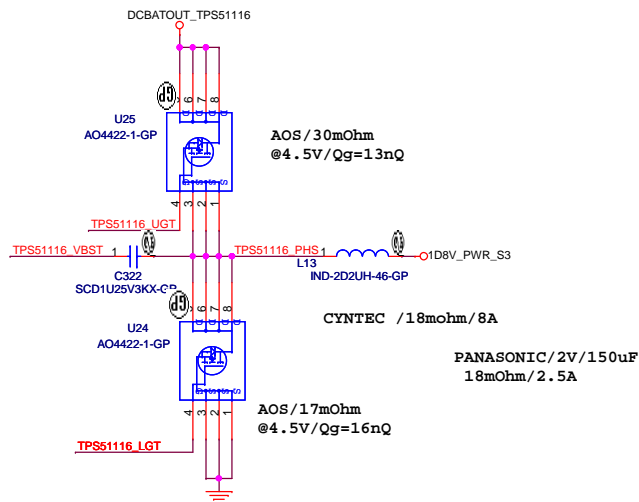

0D9V/2A , OCP >3A

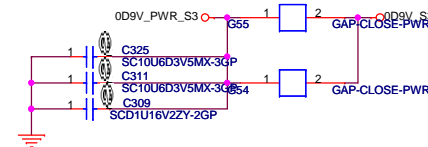

1D8V/5A , OCP >12A

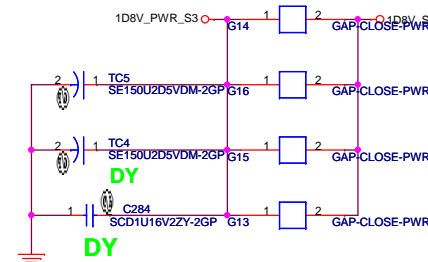

1D8V_PWR_S3 , OCP >12A

緯創資通 Wistron Corporation
21F, 88, Sec.1, Hsin Tai Wu Rd., Hsichih, Taipei Hsien 221, Taiwan, R.O.C.

Title			TPS51116 1D8V/0D9V		
Size	Document Number		Rev		
A3	SHIBA		SA		
Date:	Monday, February 20, 2006	Sheet	40	of	44

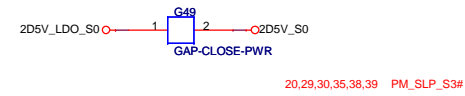
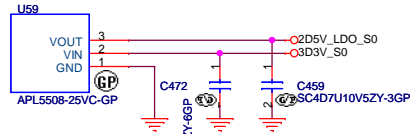

G50

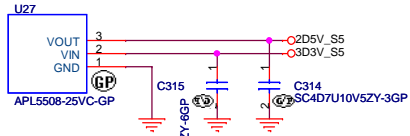

Change to S5 power plane

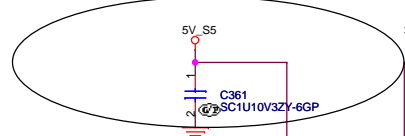

$V_o(\text{cal.}) = 1.512V$

$V_o = 0.8 * (1 + (R1/R2))$

KEMET
100uF, 4V, B2 Size, NTD:5.615
Iripple=1.1A, ESR=70mohm

$V_o = 0.8 * (1 + (R1/R2))$

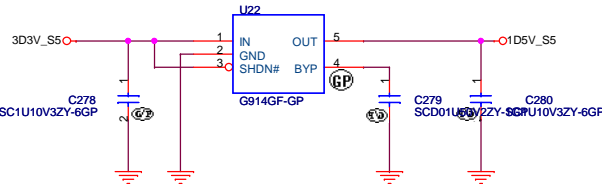

2nd source : 74.00916.D3F

1D5V_S0
Iomax=1.3A
OCP=2.6A

Trace Length=3cm
Trace Width=5mils
Trace Resistance>80mohm

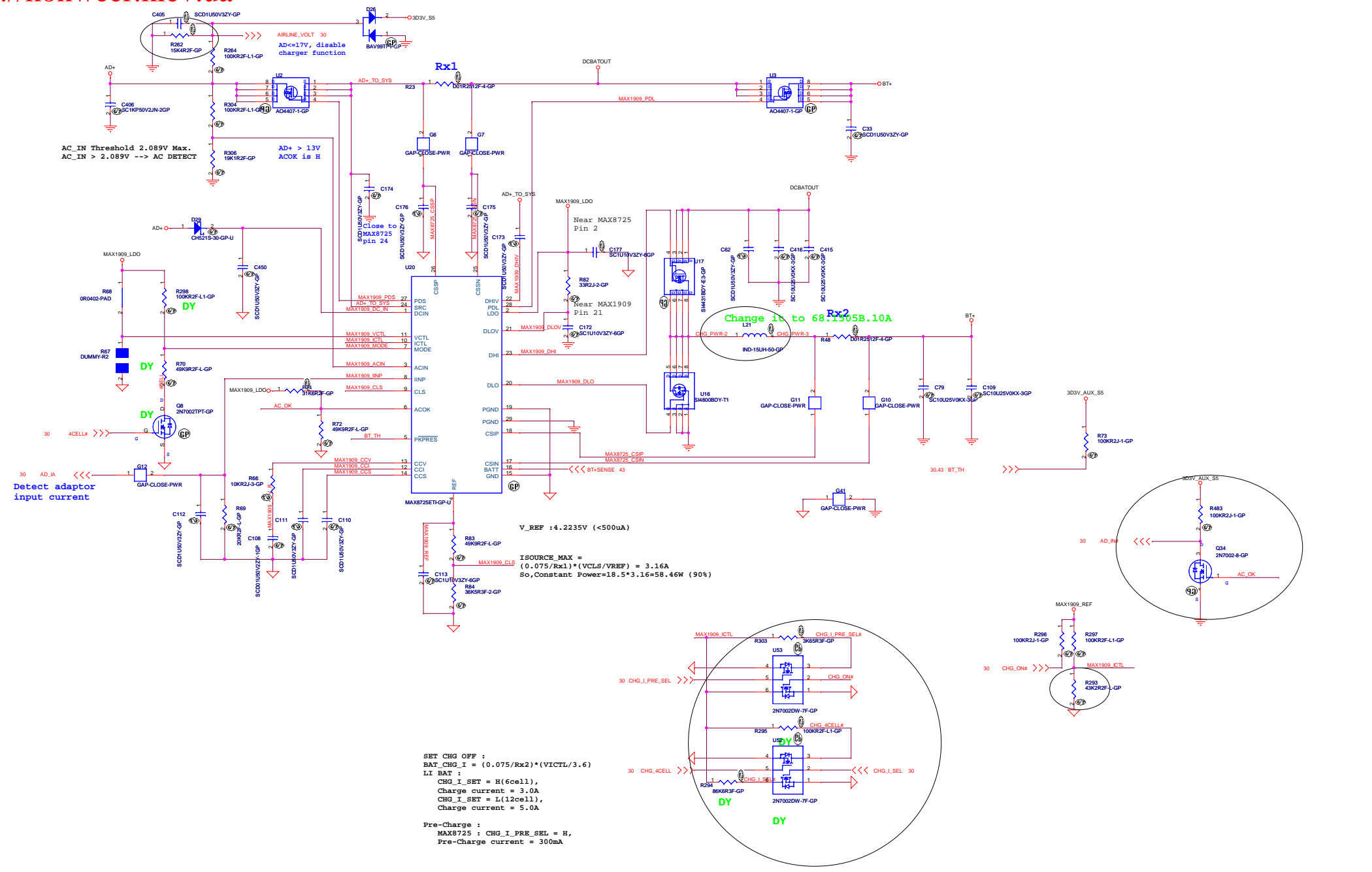

Adaptor in to generate DCBATOUT

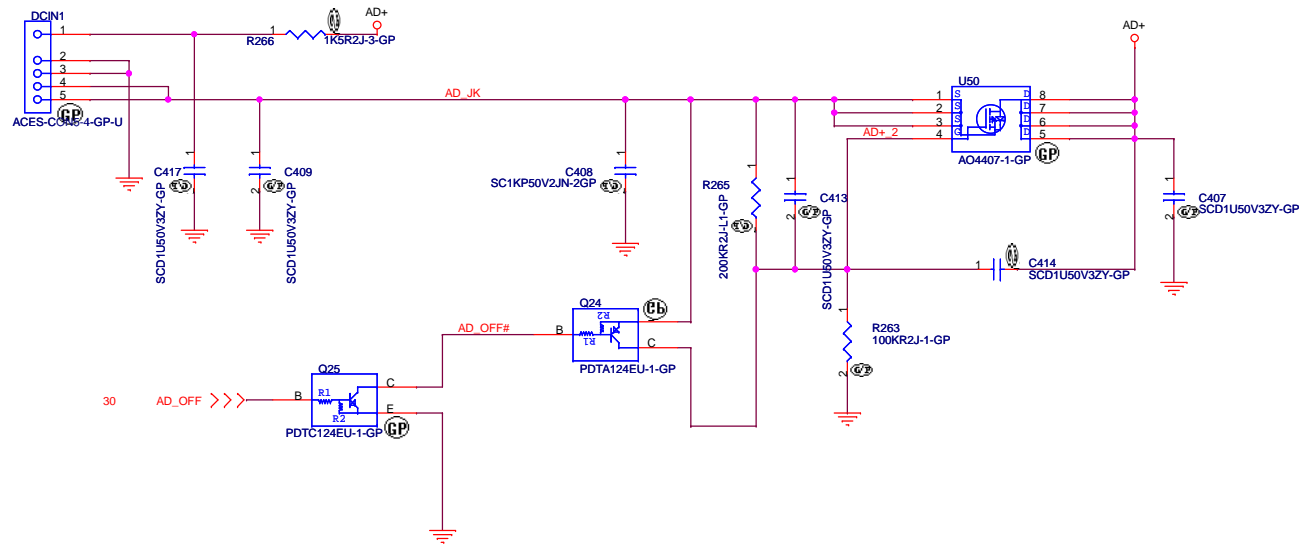

BATTERY CONNECTOR

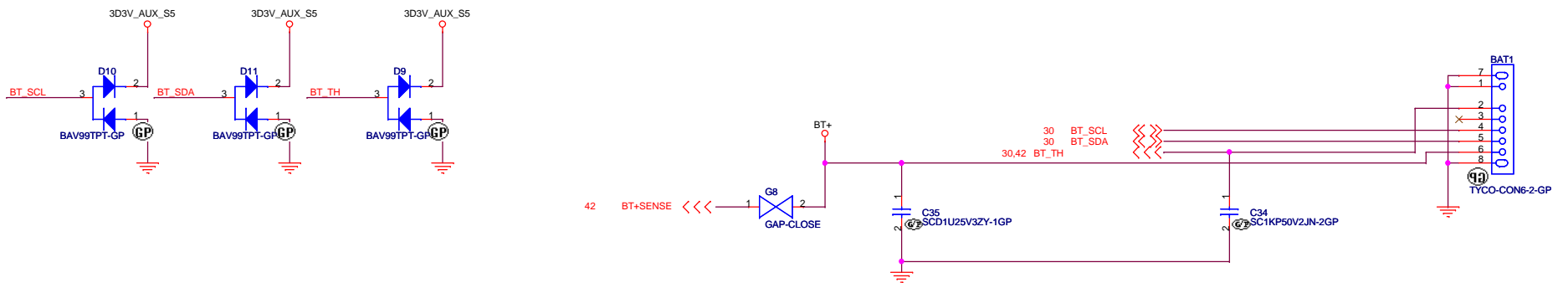

緯創資通 **Wistron Corporation**
21F, 88, Sec.1, Hsin Tai Wu Rd., Hsichih,
Taipei Hsien 221, Taiwan, R.O.C.

Title AD/BATT CONN		
Size A3	Document Number SHIBA	Rev SA
Date: Thursday, February 23, 2006	Sheet 43 of 44	

	FF	DF
CAMERA	○	×
LAN	10/100	10/100
1394/5 IN 1	○	×
EXTRA USB	○	×
MIC	○	×
CR LED	○	×

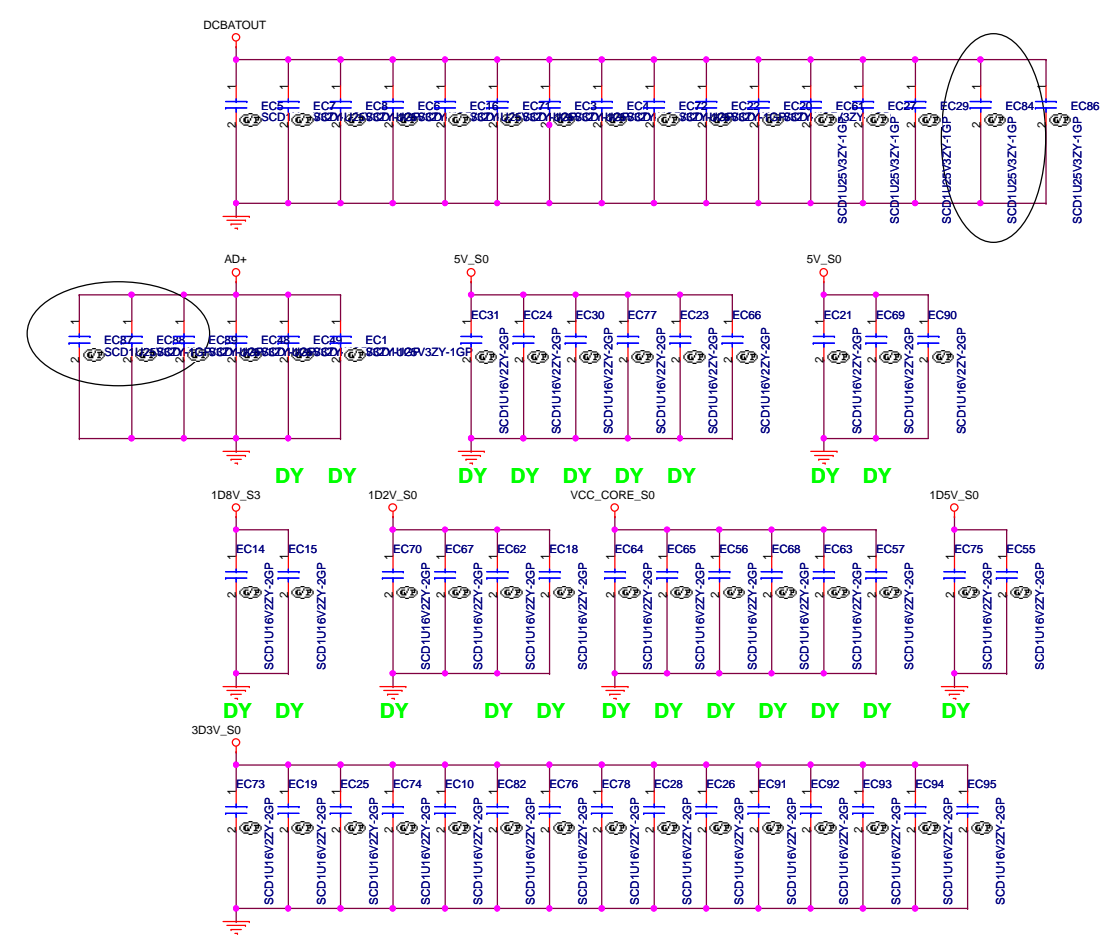
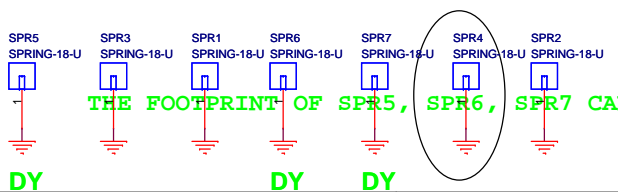
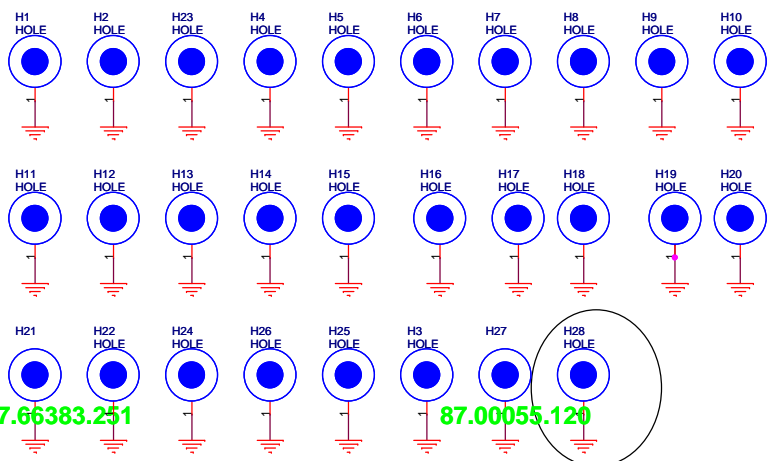
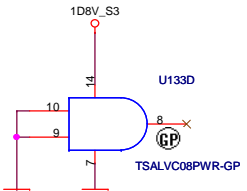

緯創資通		Wistron Corporation	
		21F, 88, Sec.1, Hsin Tai Wu Rd., Hsichih, Taipei Hsien 221, Taiwan, R.O.C.	
MISC			
Title	Document Number		Rev
Size A3	SHIBA		SA
Date: Saturday, March 04, 2006	Sheet	44	of 44