

KT2 BLOCK DIAGRAM

PENTIUM-M / Montara-GM / ICH4-M

PCB STACK UP

- LAYER 1 : TOP
- LAYER 2 : GND
- LAYER 3 : IN1
- LAYER 4 : IN2
- LAYER 5 : VCC
- LAYER 6 : BOT

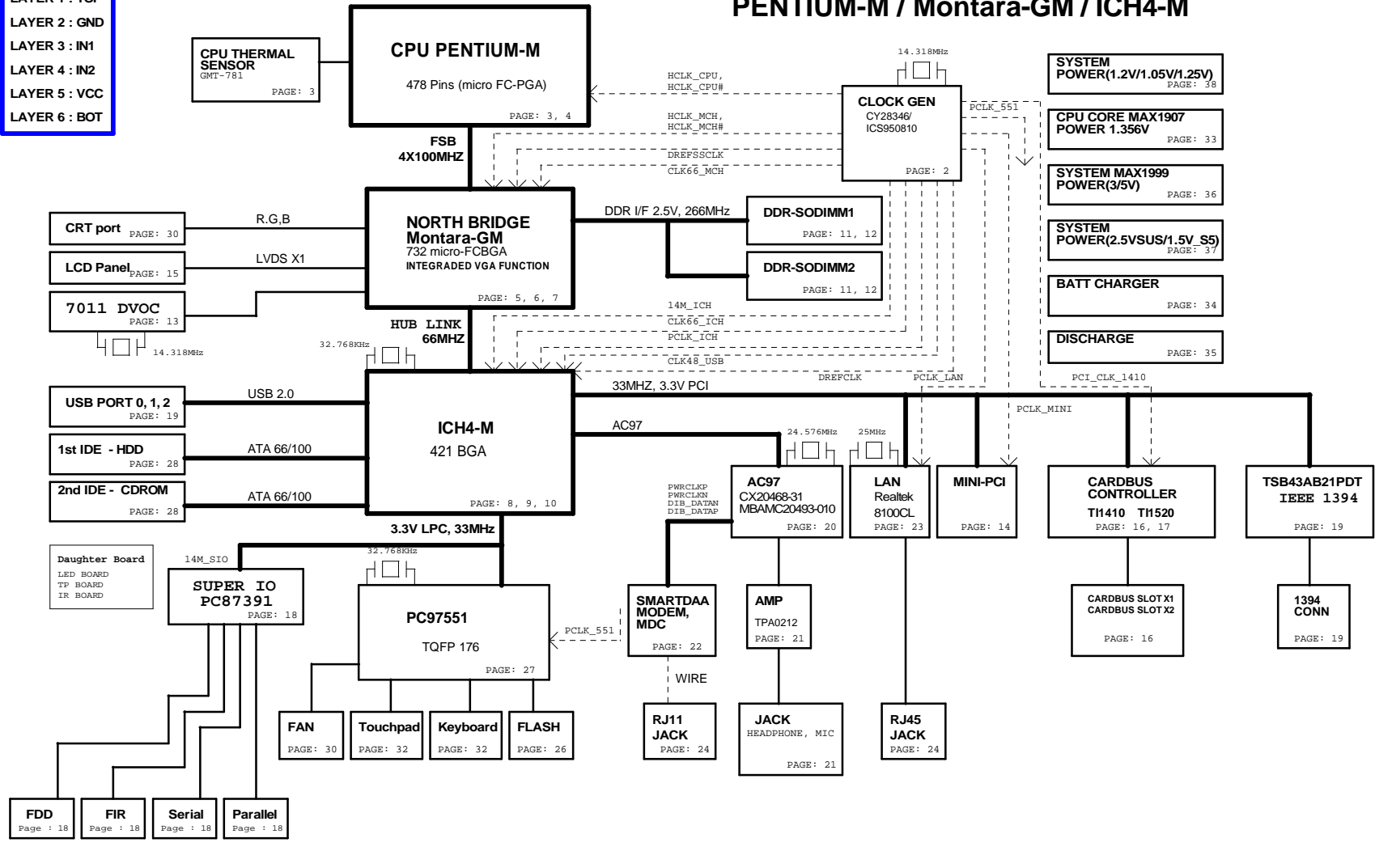

CLK GEN

S2	S1	S0	CPU	3V66[0..4]	3V66_5/66IN
1	0	0	66	66IN	66 Input
1	0	1	100	66IN	66 Input
1	1	0	200	66IN	66 Input
1	1	1	133	66IN	66 Input
0	0	0	66	66	66 Input
0	0	1	100	66	66 Input
0	1	0	200	66	66 Input
0	1	1	133	66	66 Input

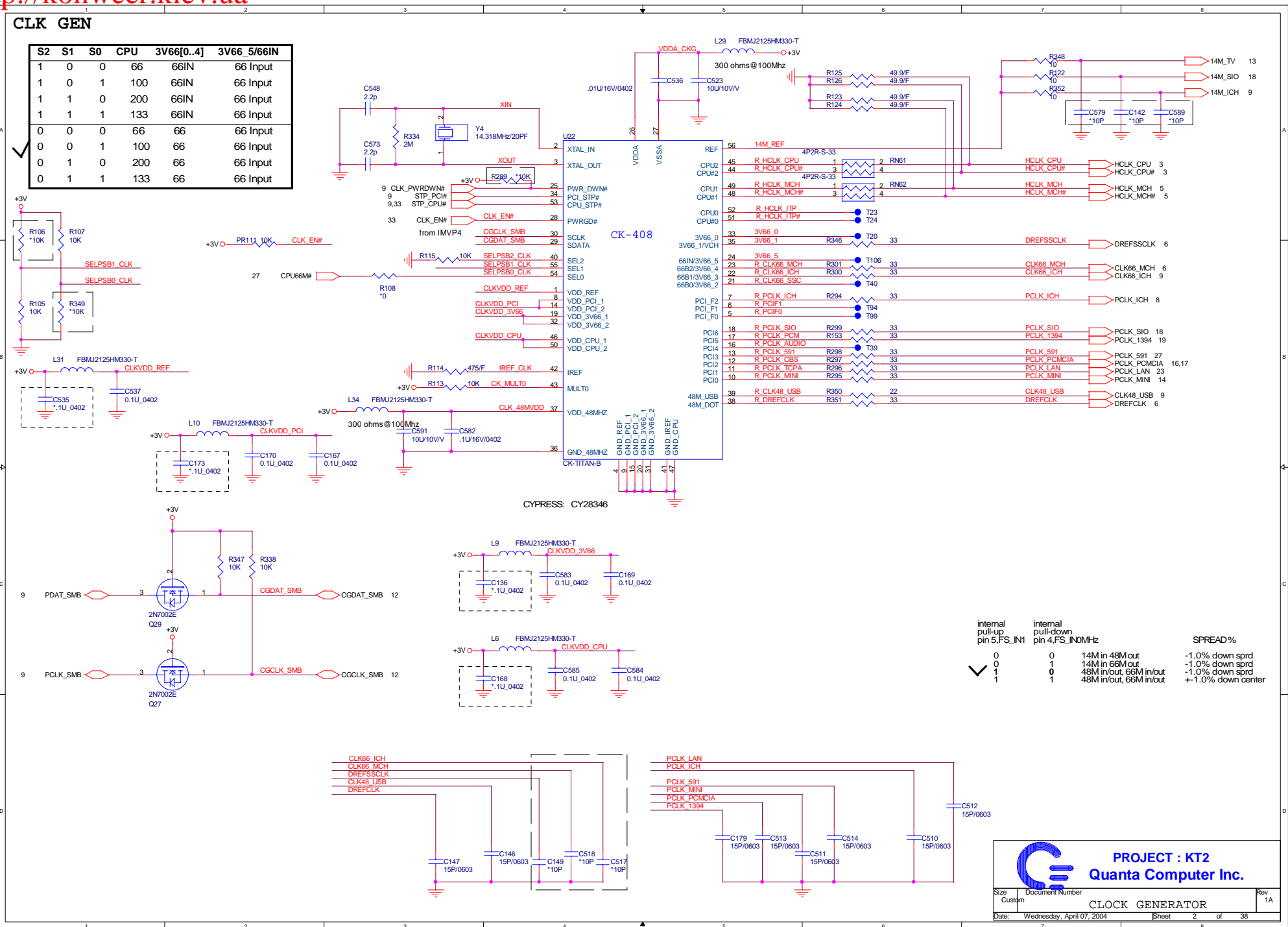

internal pull-up pin 5,FS_IN1	internal pull-down pin 4,FS_IN0MHz	SPREAD%
0	0	14M in 48M out -1.0% down sprd
0	1	14M in 66M out -1.0% down sprd
1	0	48M in/out, 66M in/out -1.0% down sprd
1	1	48M in/out, 66M in/out +1.0% down center

PROJECT : KT2
Quanta Computer Inc.

Size: Custom Document Number: **CLOCK GENERATOR** Rev: 1A

Date: Wednesday, April 07, 2004 Sheet: 2 of 38

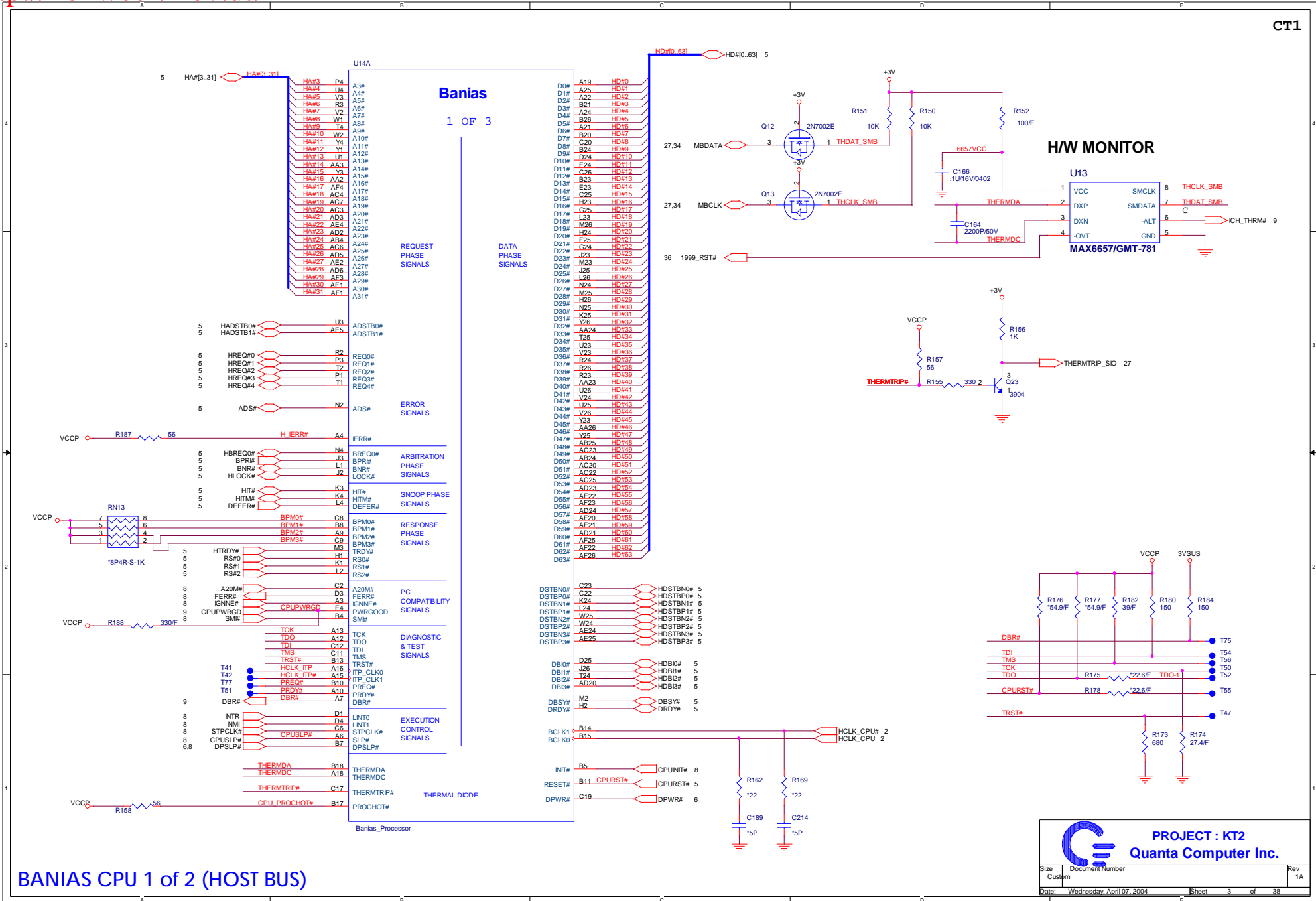

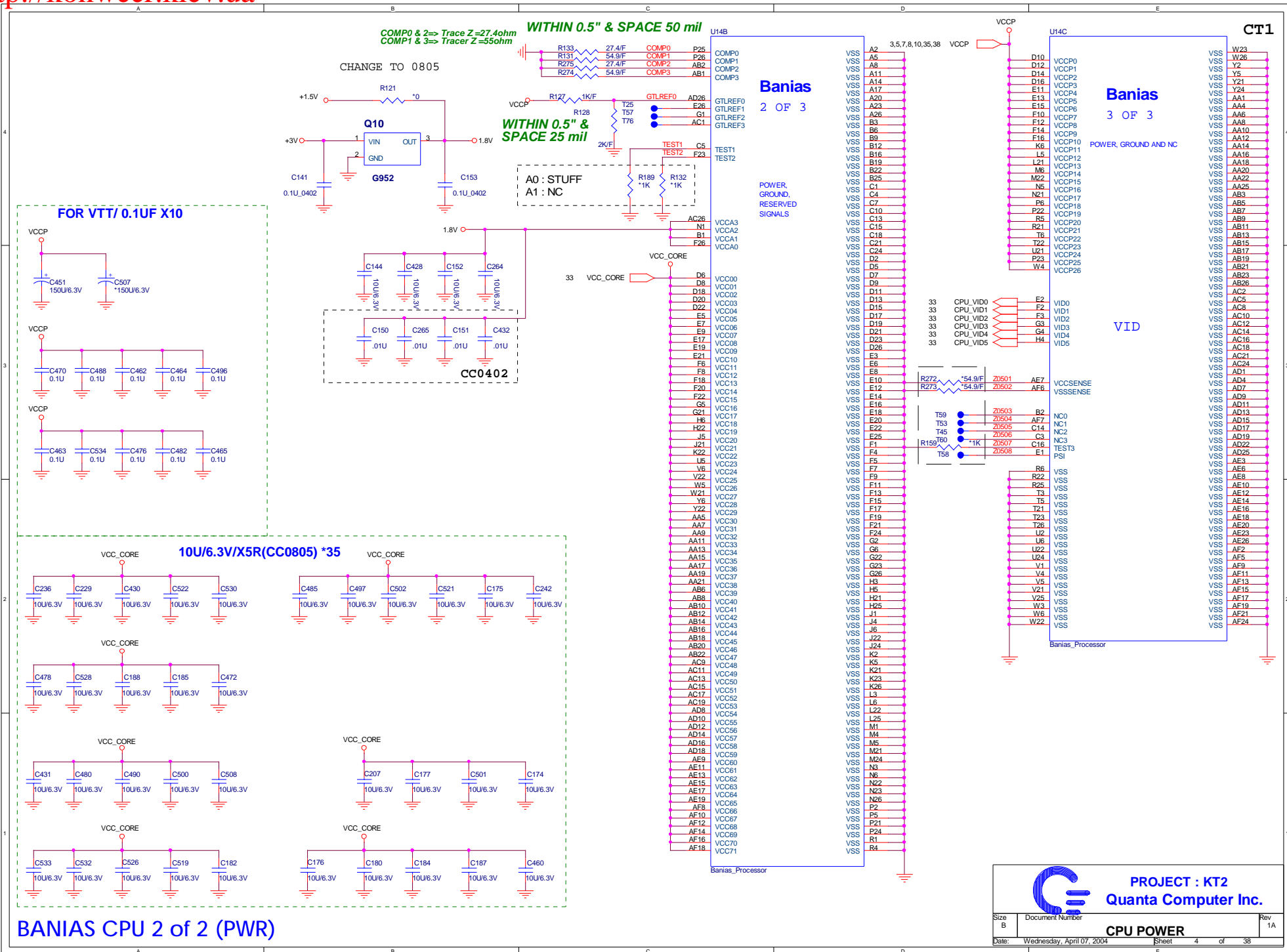

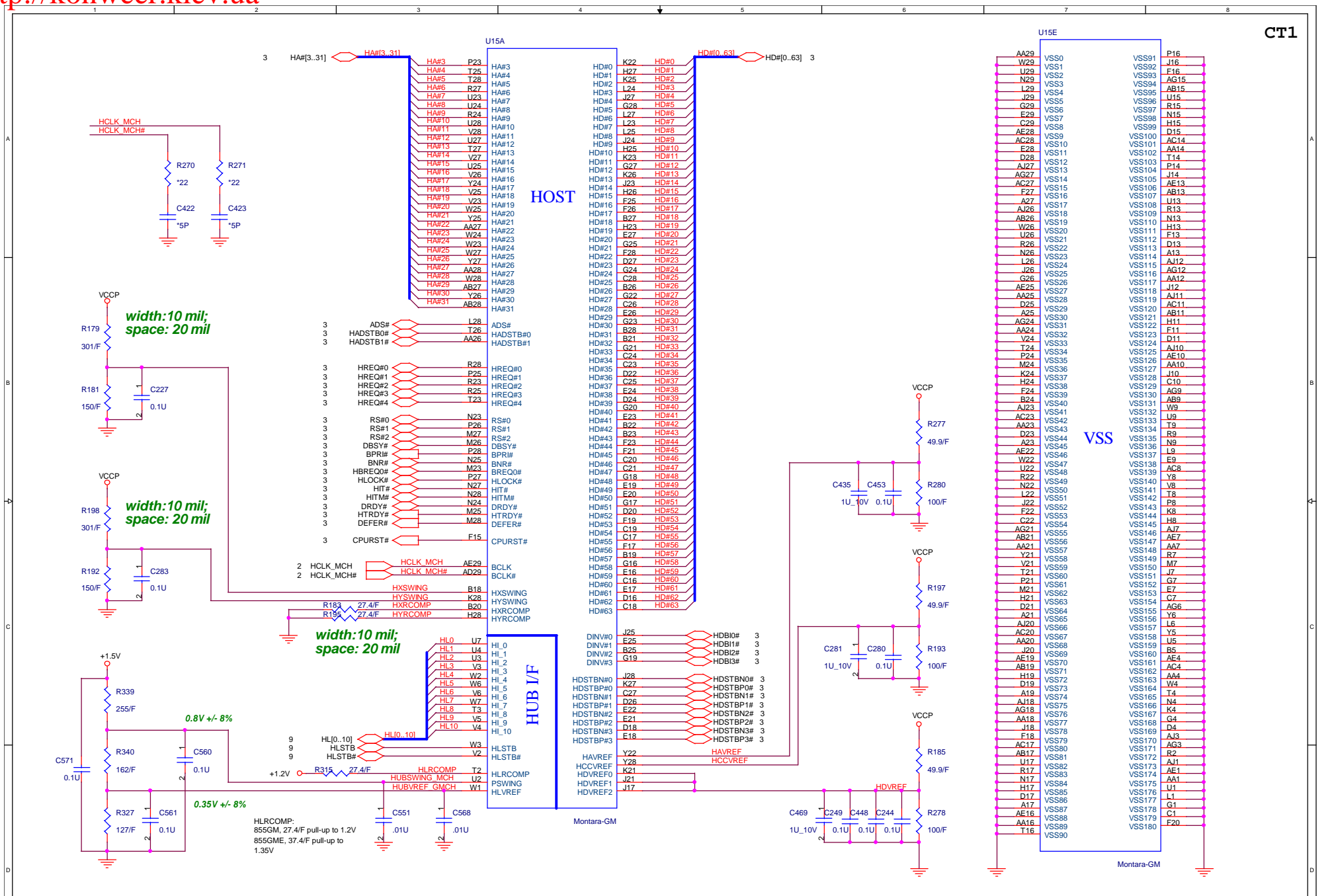

MONTARA-GME/ 855GM+ 1of 3 (HOST & GND)

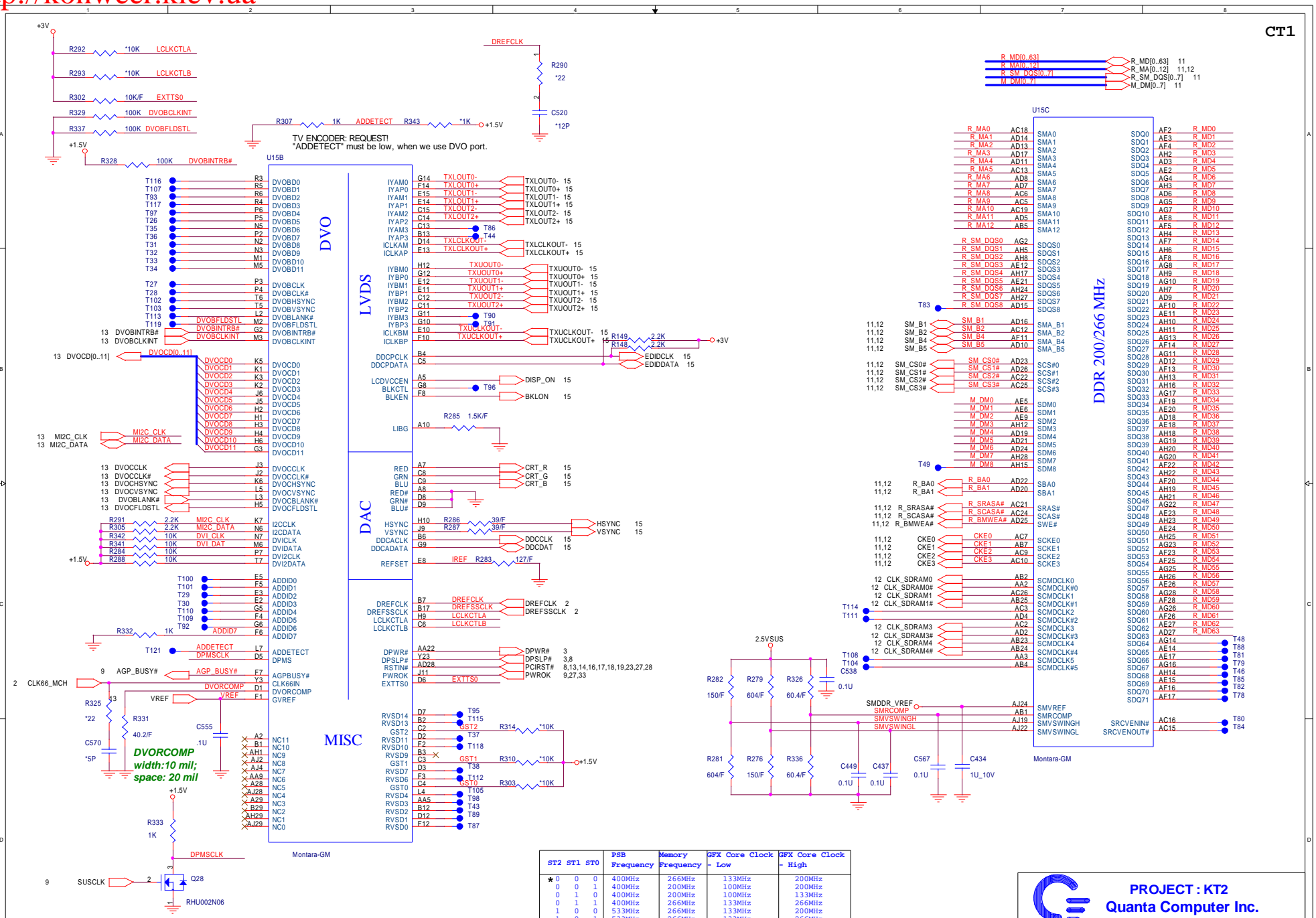

PROJECT : KT2
Quanta Computer Inc.

Size	Document Number	Rev
Custom	MontaraGM_A	1A
Date: Wednesday, April 07, 2004		Sheet 5 of 38

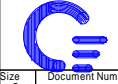

MONTARA-GME/ 855GM+ 2 of 3 (DVO & DDR)

ST2	ST1	ST0	PSB Frequency	Memory Frequency	GFX Core Clock - Low	GFX Core Clock - High
* 0	0	0	400MHz	266MHz	133MHz	200MHz
0	0	1	400MHz	200MHz	100MHz	200MHz
0	1	0	400MHz	200MHz	100MHz	133MHz
0	1	1	400MHz	266MHz	133MHz	266MHz
1	0	0	533MHz	266MHz	133MHz	266MHz
1	0	1	533MHz	266MHz	166MHz	266MHz
1	1	0	400MHz	333MHz	166MHz	250MHz



SRCTENIN#
SRCTENOUT#
SRCTENIN#
SRCTENOUT#

MontaraGM_B
 Date: Wednesday, April 07, 2004
 Sheet 8 of 38

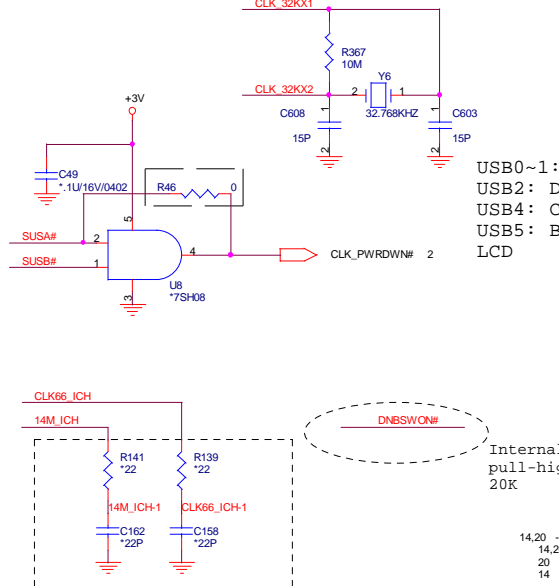
ICH4-M

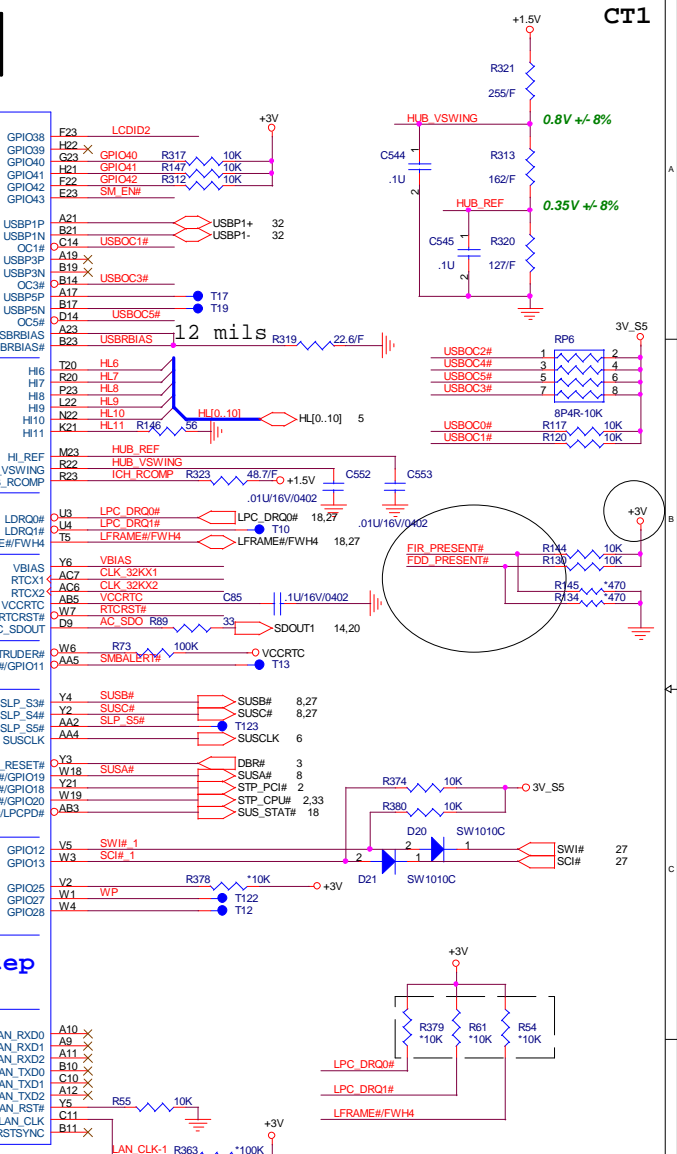
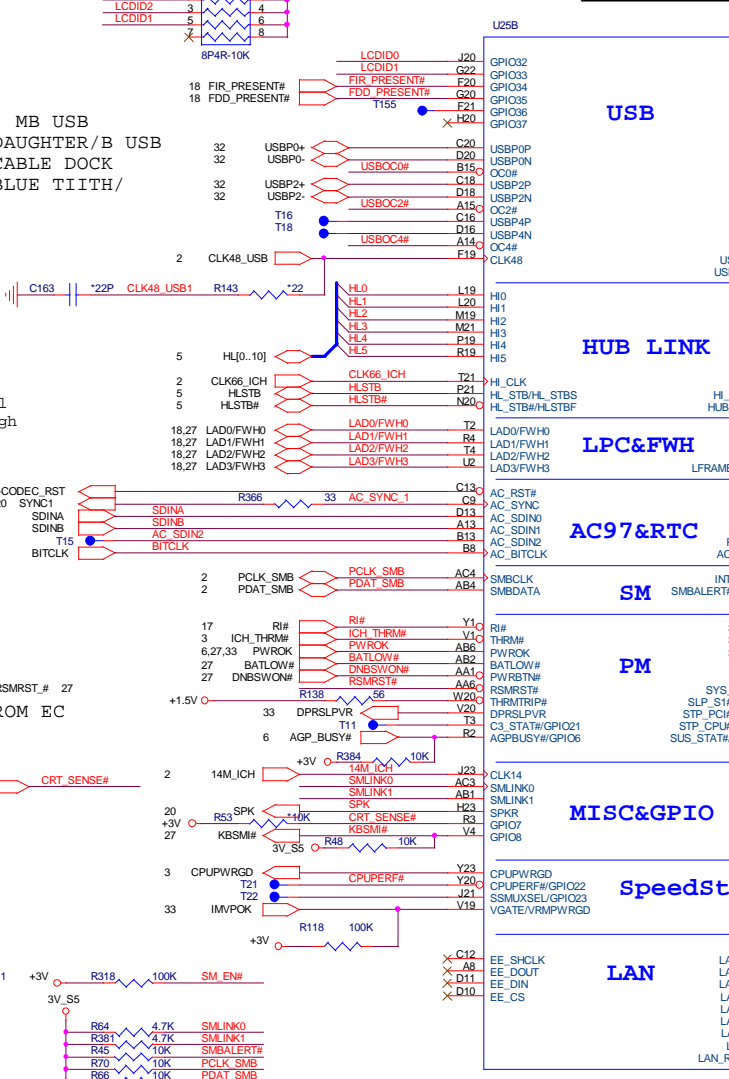

ICH4-M



ICH4-M 2/3 (USB, HUB LINK, LPC&FWH, AC97, SM, PM, MISC&GPIO, LAN)

PROJECT : KT2
Quanta Computer Inc.

Size Custom
 Document Number ICH4-M USB,HUB & LPC INTERFACE
 Rev 1A

Date: Wednesday, April 07, 2004
 Sheet 9 of 38

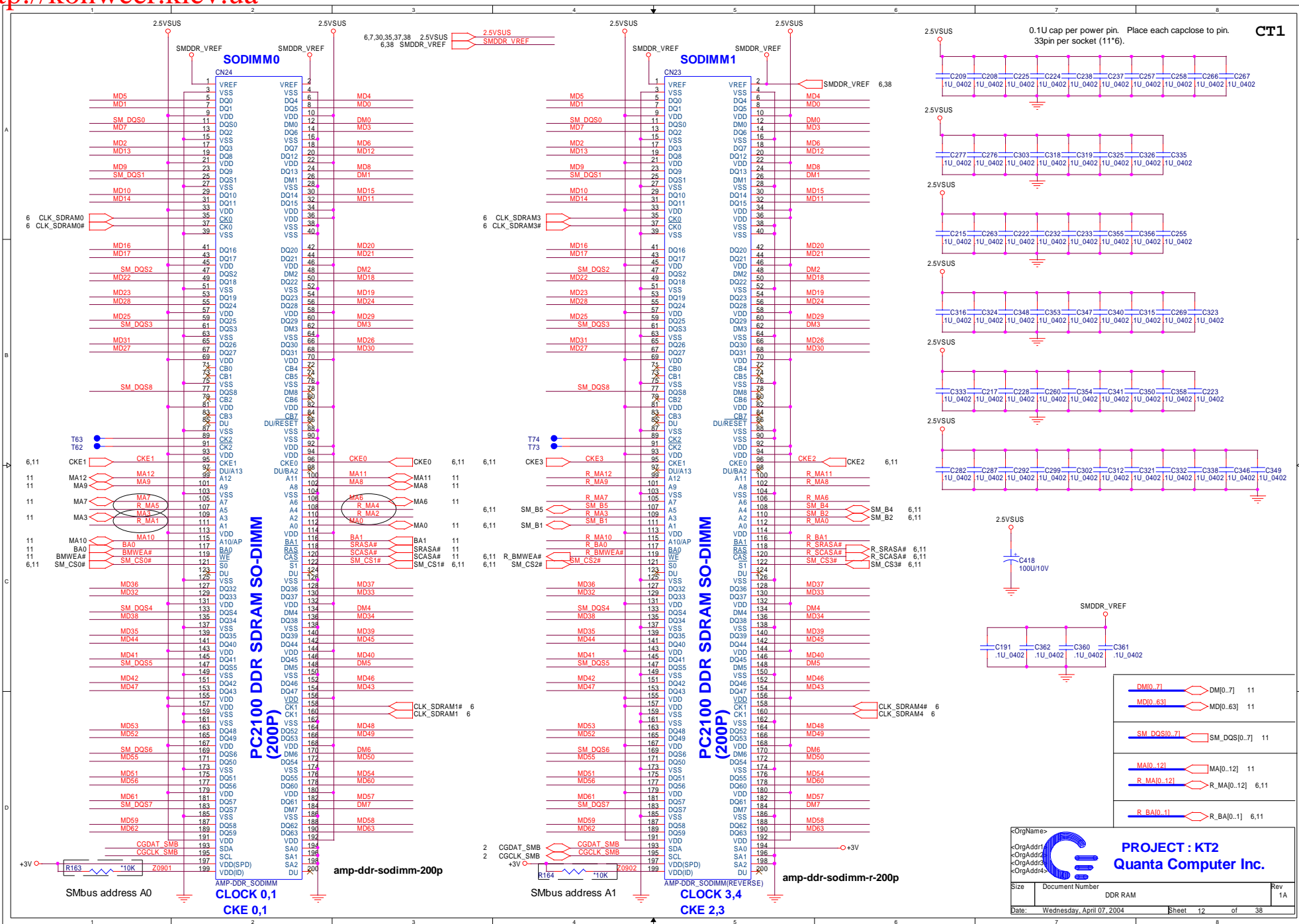

- DM[0..7] 11
- MD[0..63] 11
- SM_DQS[0..7] 11
- MA[0..12] 11
- R_MA[0..12] 6,11
- R_BA[0..1] 6,11

PROJECT : KT2
Quanta Computer Inc.

Size	Document Number	DDR RAM	Rev
			1A
Date:	Wednesday, April 07, 2004	Sheet 12 of 38	

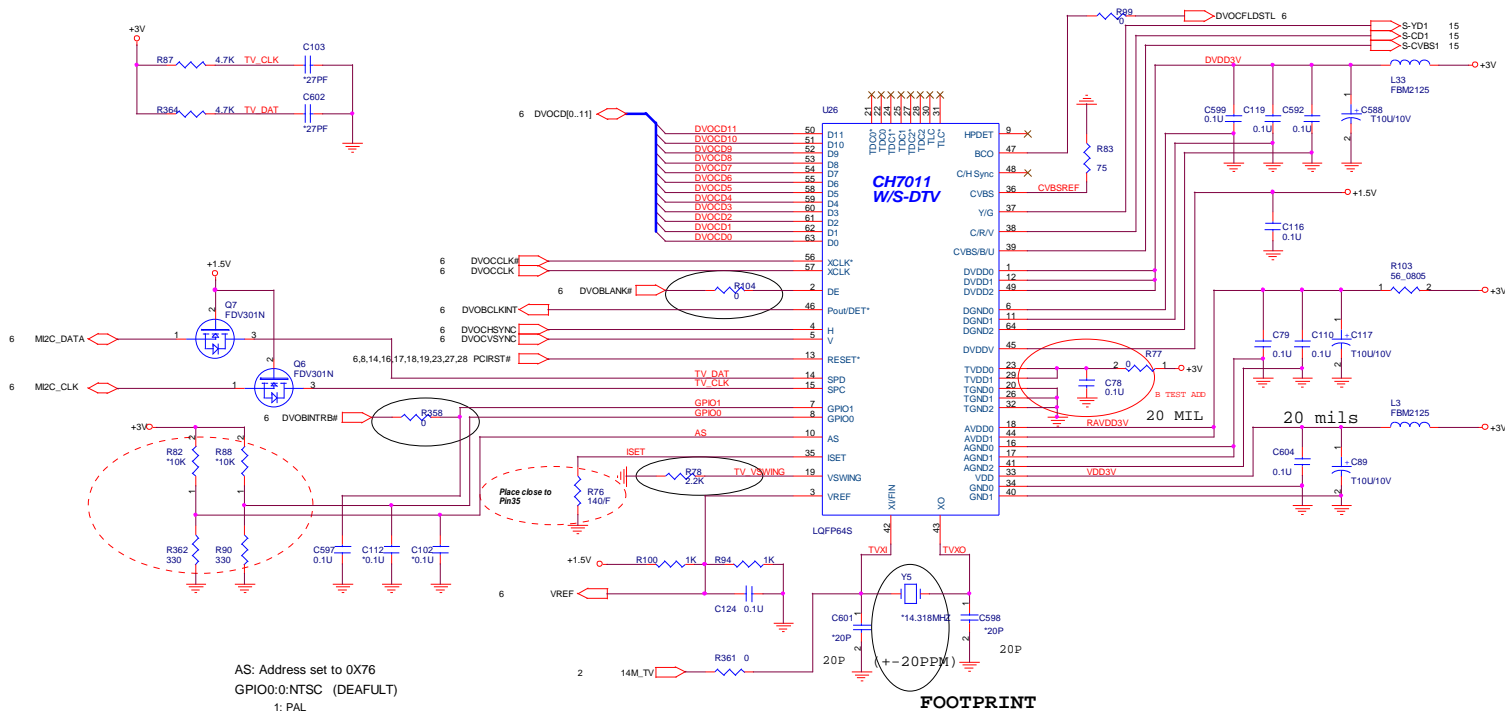

PROJECT : KT2
Quanta Computer Inc.

Size	Document Number	Rev
C	13--TV ENCODER (CH7011)	1/A
Date	Wednesday, April 07, 2004	Sheet 13 of 38

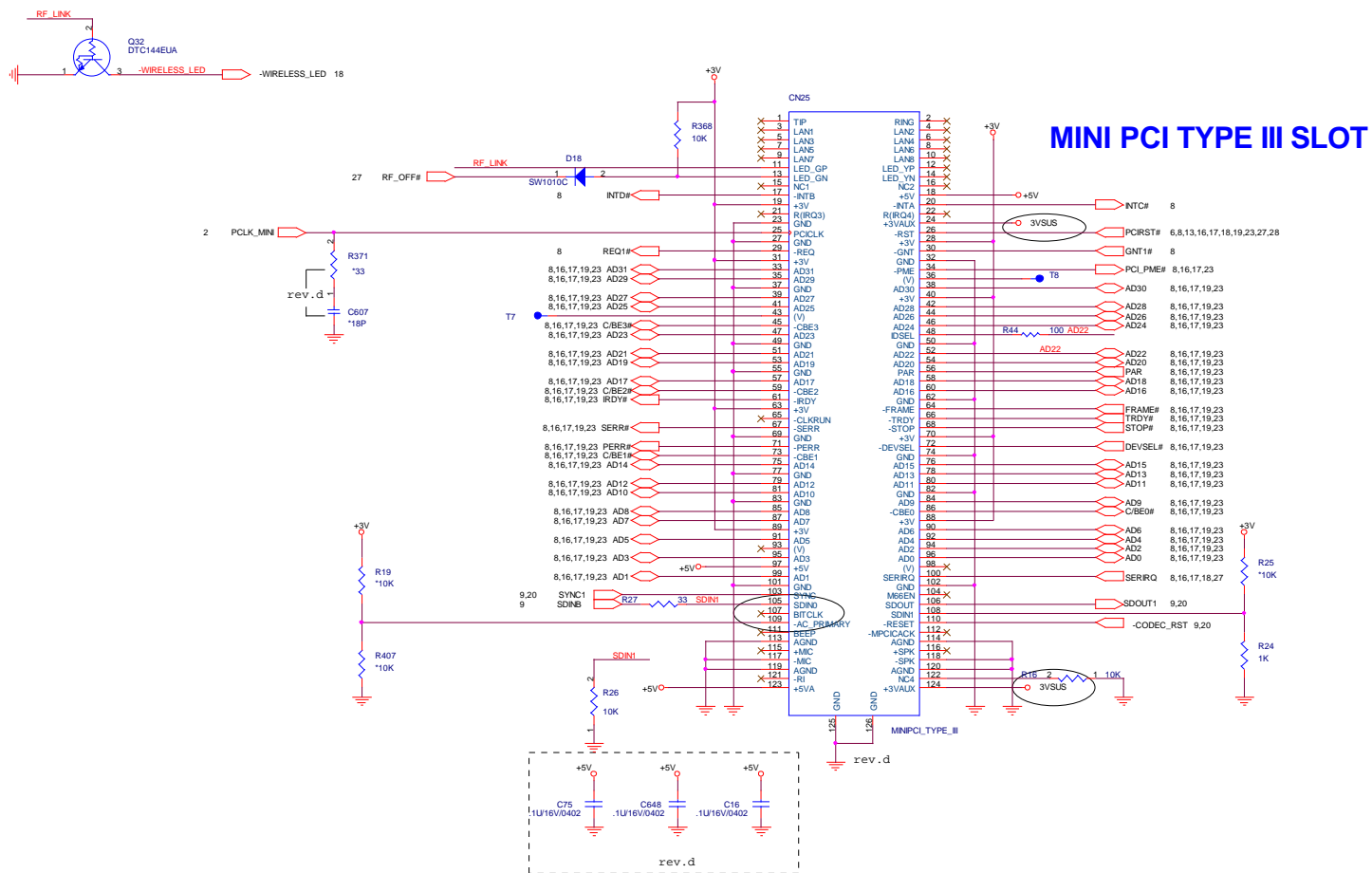

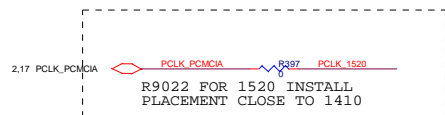

- 8.17 GNT0#
- 8.17 REQ0#
- 8.14,17,19,23 CBE2#
- 8.14,17,19,23 CBE2#
- 8.14,17,19,23 CBE2#
- 8.14,17,19,23 CBE2#
- 8.14,17,19,23 FRAME#
- 8.14,17,19,23 DEVSSEL#
- 6.8,13,14,17,18,19,23,27,28 PCIRST#
- 8.14,17,19,23 TRDY#
- 8.14,17,19,23 RDY#
- 8.14,17,19,23 STOP#
- 8.14,17,19,23 PERR#
- 8.14,17,19,23 SERR#
- 8.14,17,19,23 PAR#
- 6.8,13,14,17,18,19,23,27,28 PCIRST#

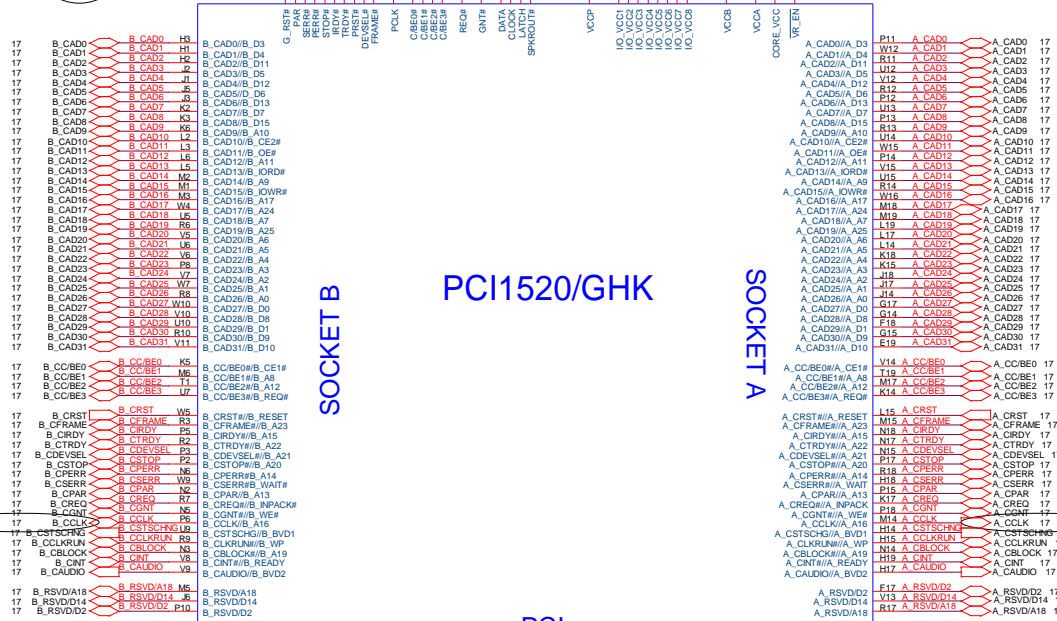
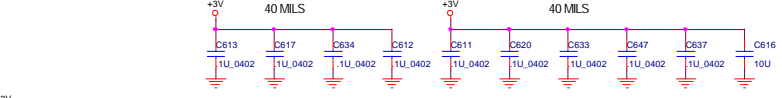
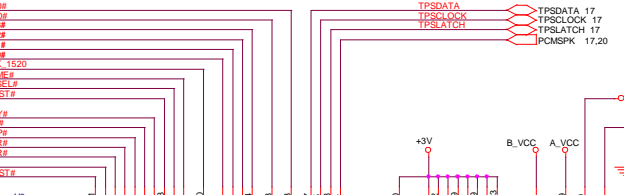

Correct module name: BCVS1, BCVS2#

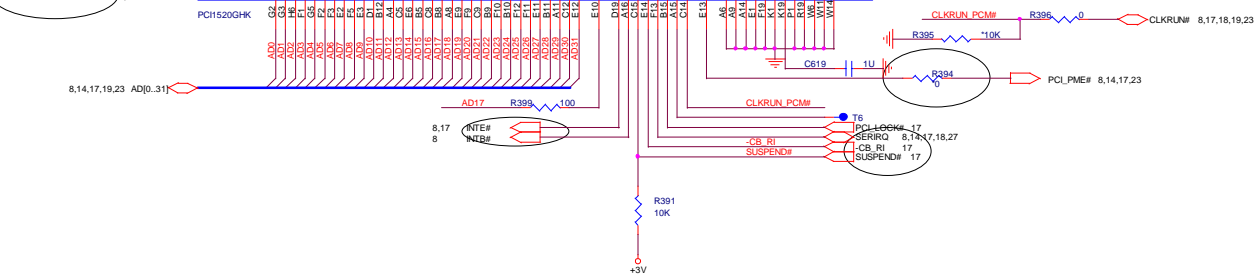

IEEE-1394

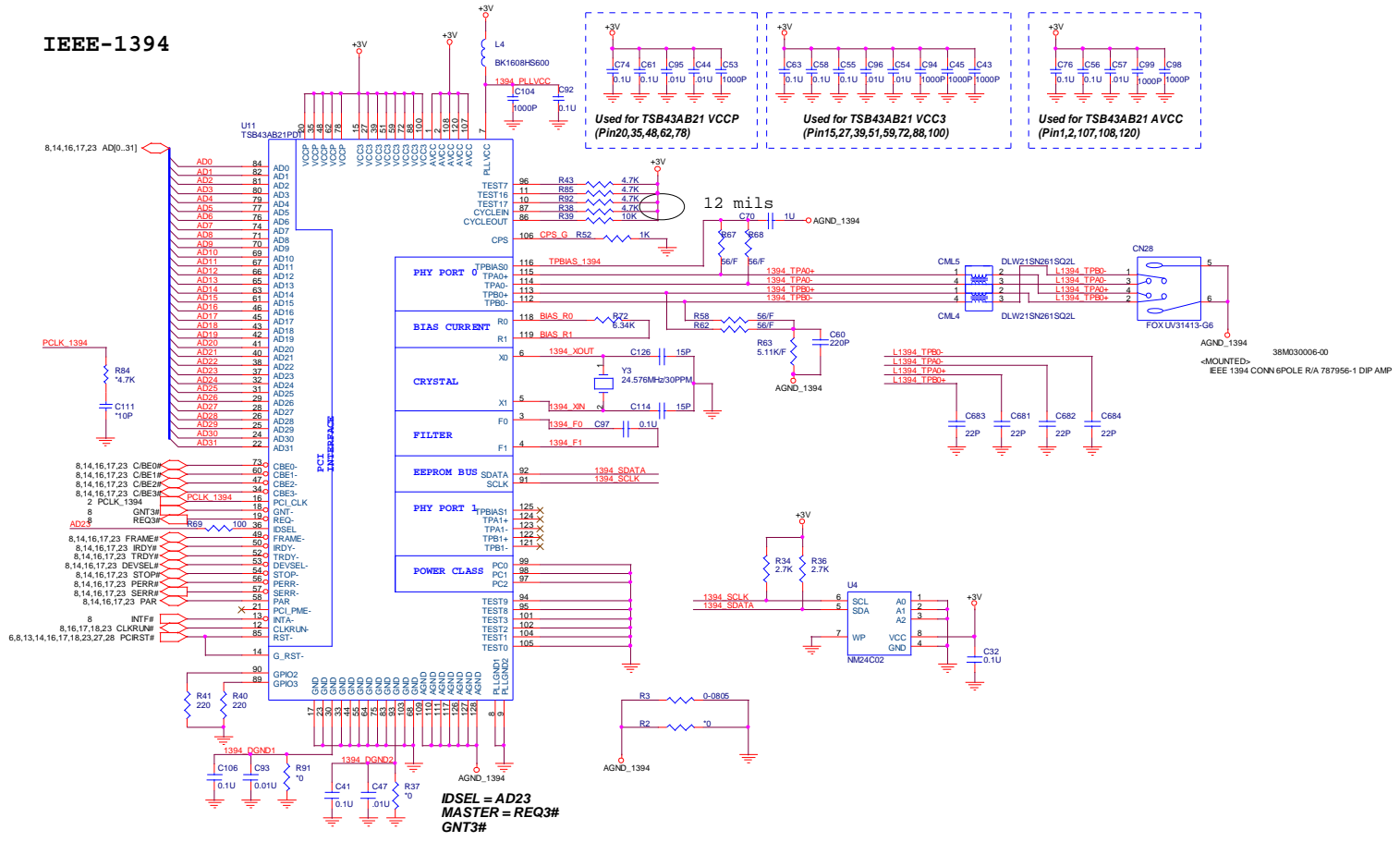

PROJECT : KT2
Quanta Computer Inc.

Size C Document Number 19-IEEE1394a (43AB21A) Rev 1/A
 Date: Wednesday, April 07, 2004 Sheet 19 of 38

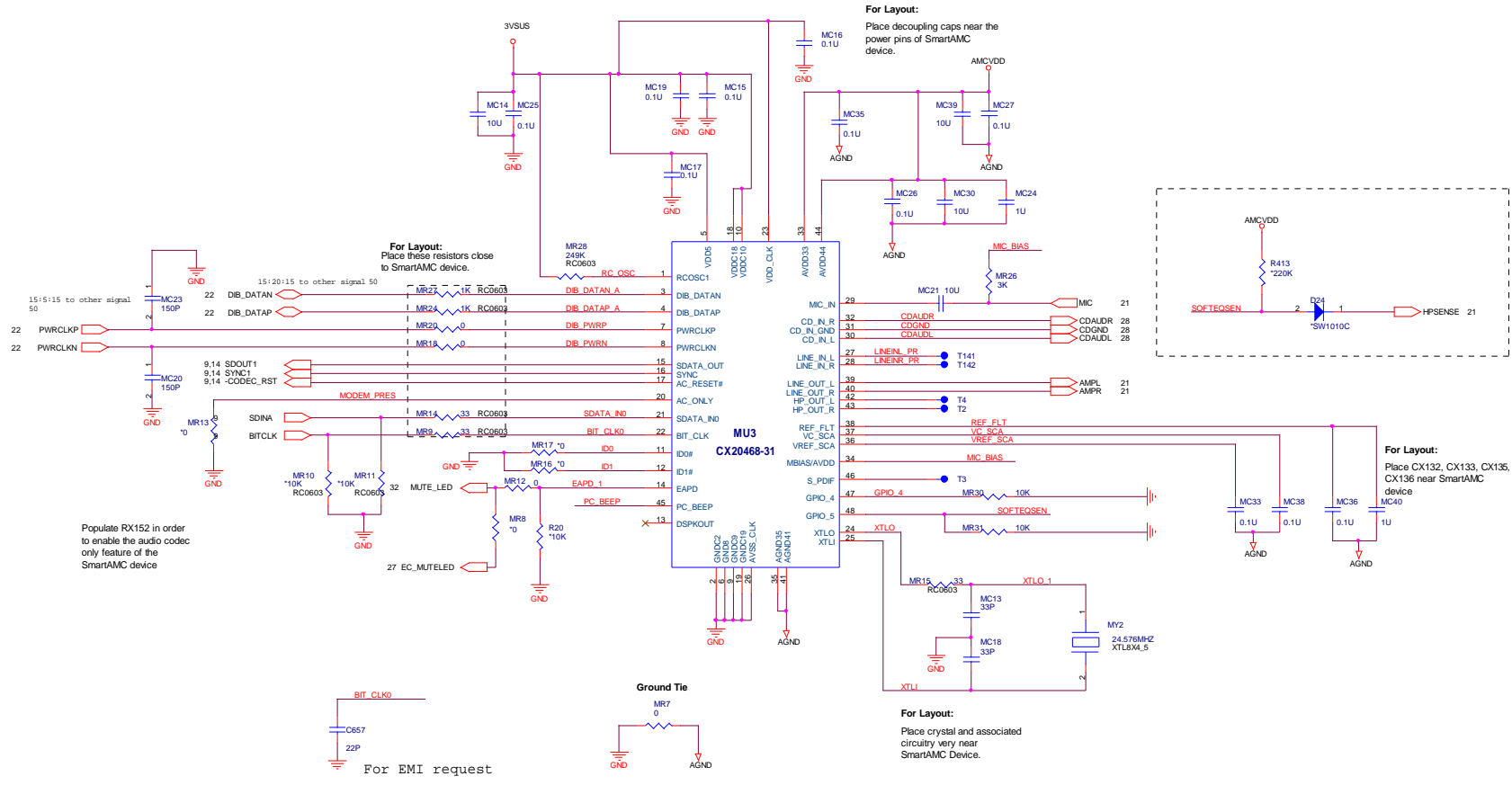

PC SPEAKER

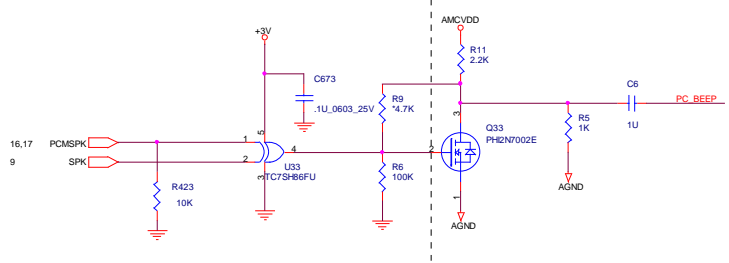

- CX20468-21: ADD R9026, MR9, MR19
REMOVE MR8, R9025, D8
- CX20468-31: ADD MR8, R9025, D8
REMOVE R9026, MR9, MR19
- CX20468-31 without software EQ:
ADD MR8, MR9
REMOVE R9025, D8

PROJECT : KT2
Quanta Computer Inc.

Size	Document Number	Rev
C	20--AC97 CTRL_CONEXANT20468-31	1A
Date:	Wednesday, April 07, 2004	Sheet 20 of 38

	8100CL(10/100M)	8110SB(1G)
DVDD33	3.3VD 26, 41, 56, 71, 84, 94, 107	3.3VD 26, 41, 56, 71, 84, 94, 107
AVDDL	3.3VA 3, 7, 20	2.5VA 3, 7, 20, 16
DVDD	2.5VD 32, 54, 78, 99	1.8VD 32, 54, 78, 99, 24, 45, 64, 110, 116, 126
AVDD25	2.5VA 12	NC
AVDDH	NC	3.3VA 10, 120

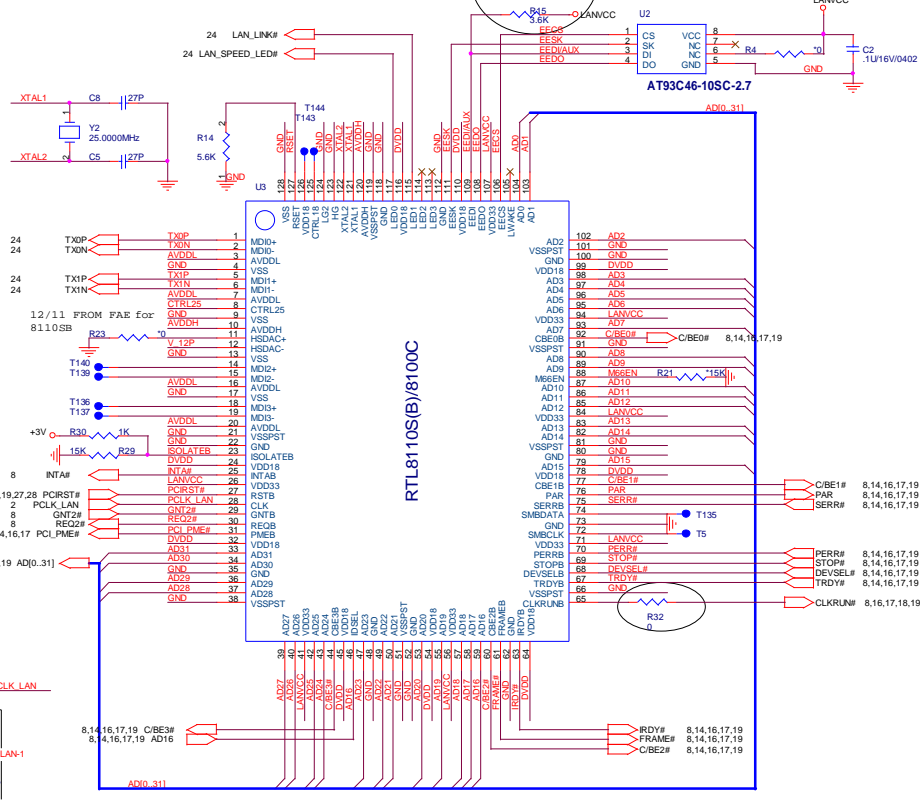
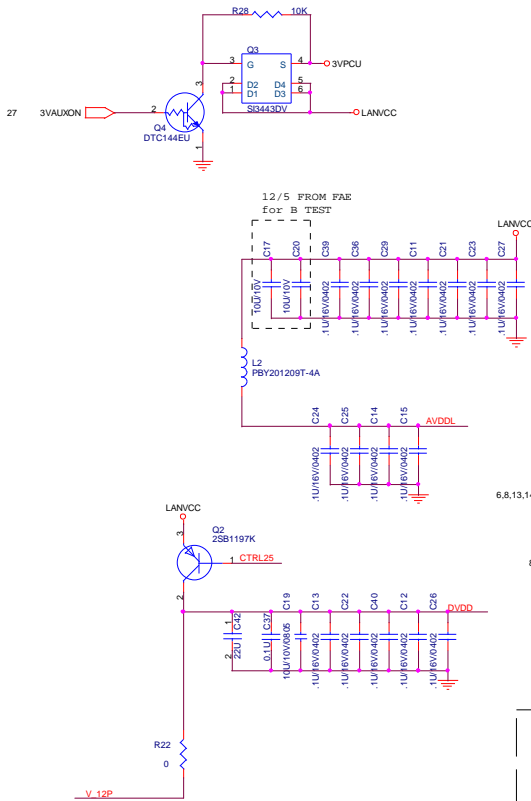

PROJECT : KT2
 Quanta Computer Inc.

Size C Document Number 23--LAN (RTL8100CL) Rev 1/A
 Date: Wednesday, April 07, 2004 Sheet 23 of 38

Close to Chip

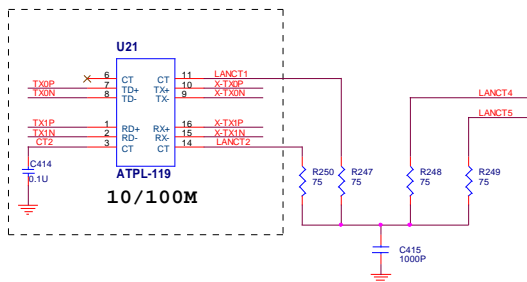
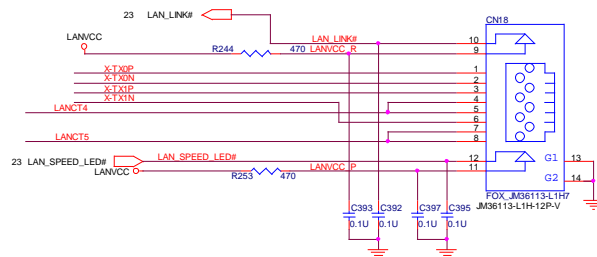
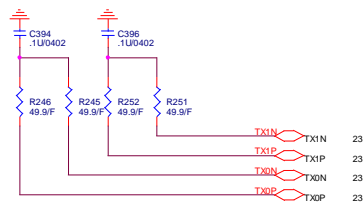

RJ11 CONNECTOR

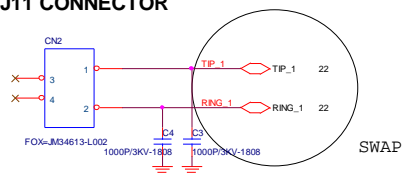



		PROJECT : KT2	
		Quanta Computer Inc.	
Size	Document Number	Rev	Rev
C	26-RESERVED	1A	1A
Date	Wednesday, April 07, 2004	Sheet	26 of 38

KBC-NS87551L

LDRQ#(pin 8) internal is no use
9,18 LPC_DRQ0# LPC_DRQ0# R385 DRO0#

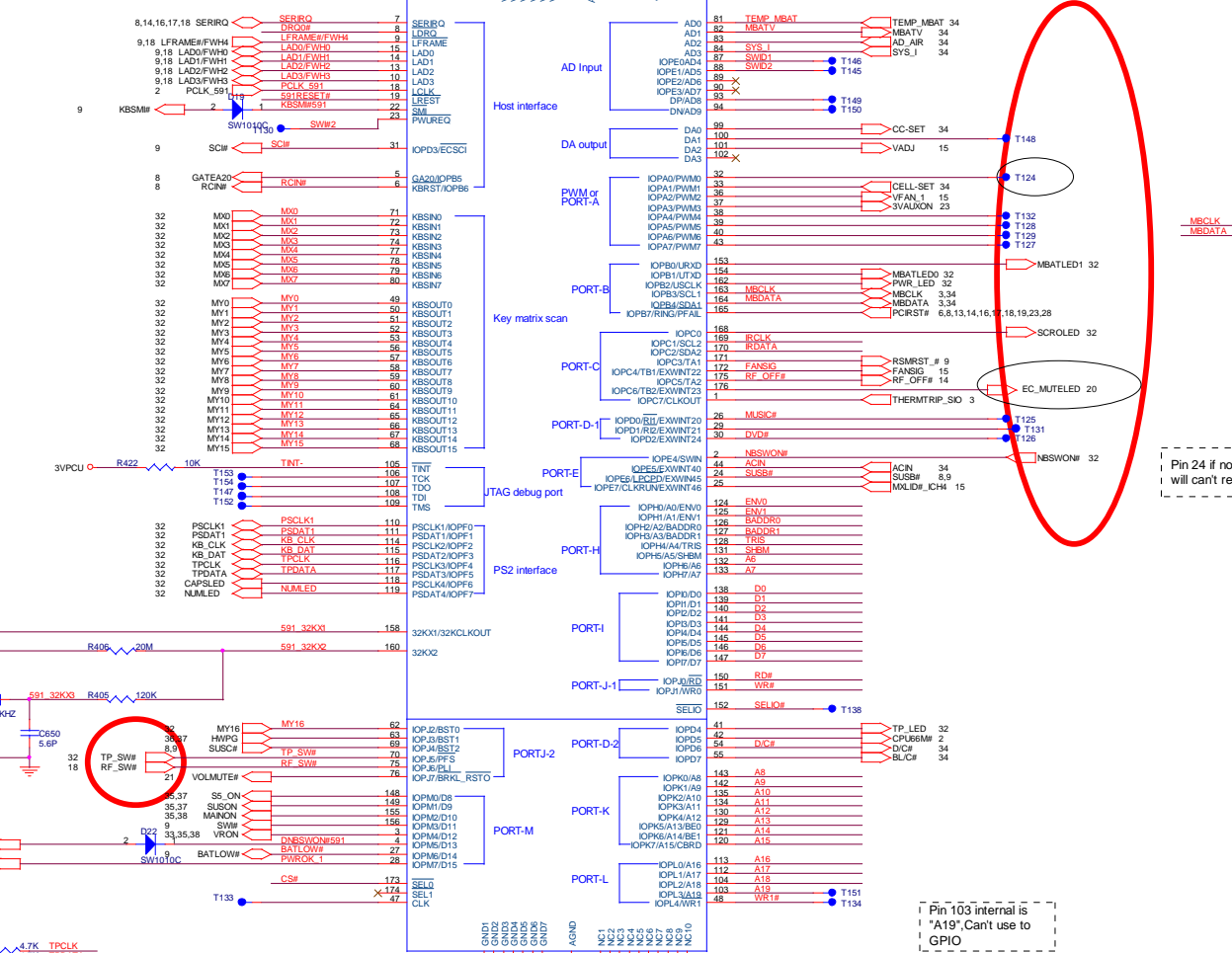
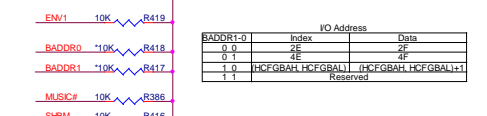
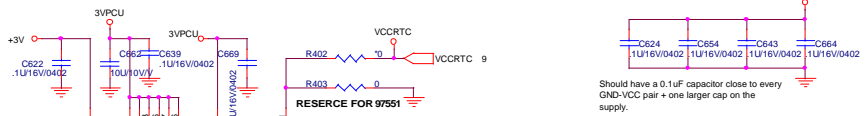

Pin 24 if no pull-high, will can't reboot.

Pin 103 internal is "A19". Can't use to GPIO

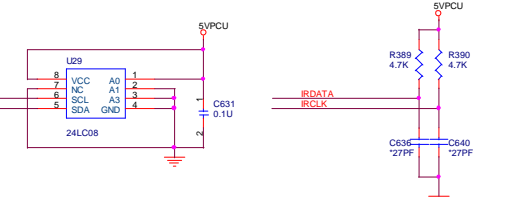

BIOS ROM

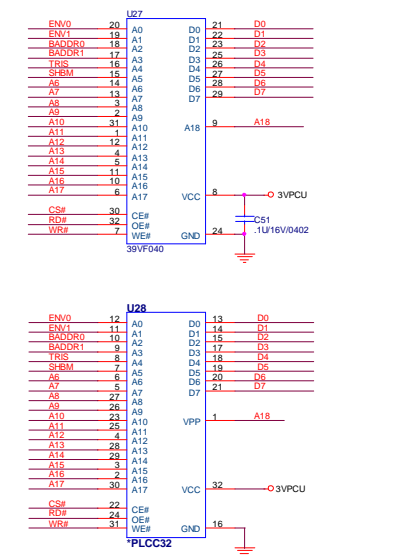

PC97551

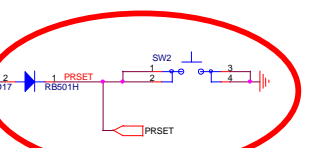
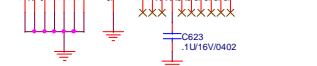

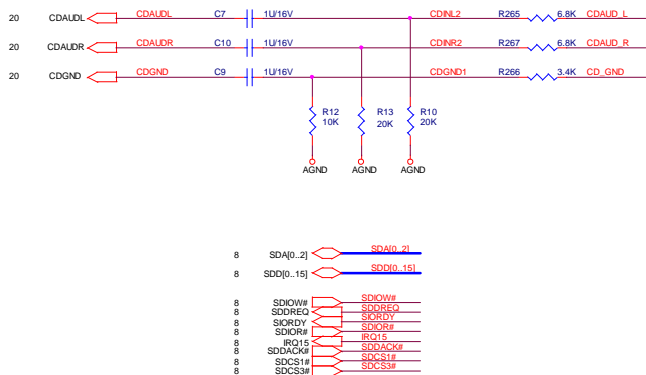

CD-ROM

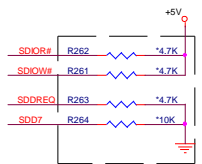
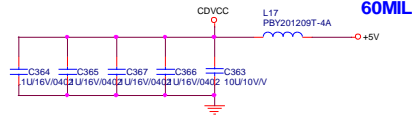
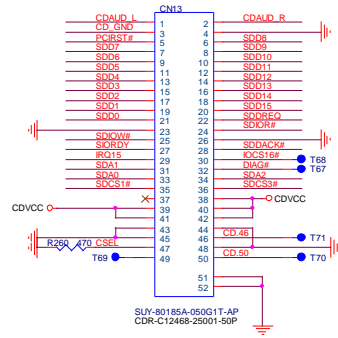

HDD CONNECTOR

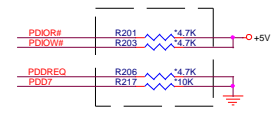
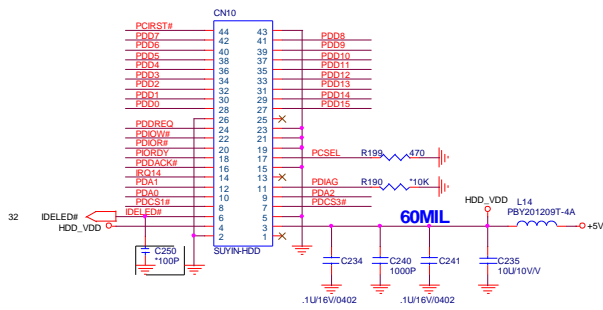
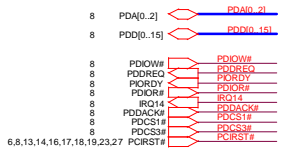

PROJECT : KT2
Quanta Computer Inc.

Size C Document Number 28--HDD_ODD Rev 1/A

Date Wednesday, April 07, 2004 Sheet 28 of 38

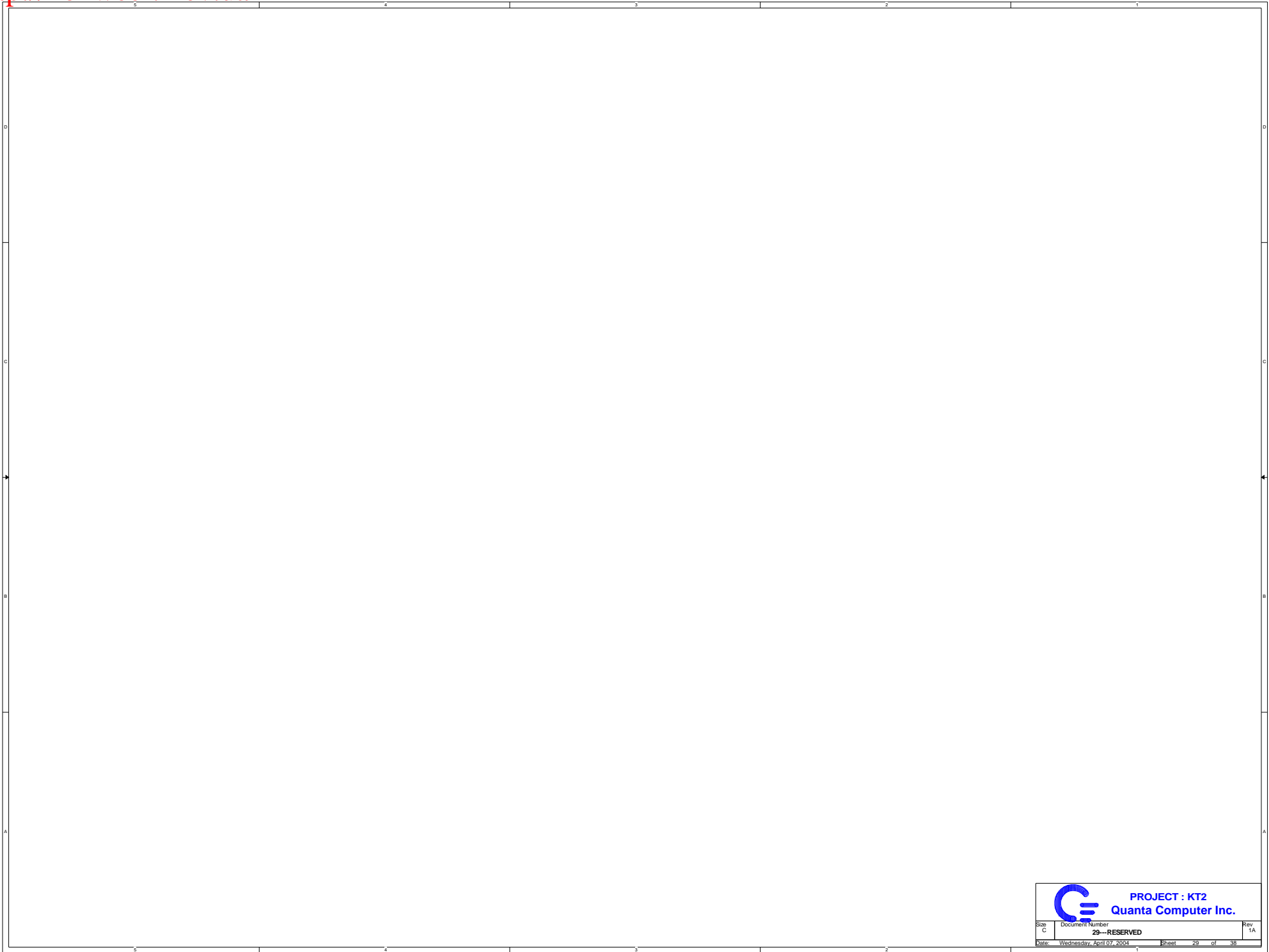

		PROJECT : KT2	
		Quanta Computer Inc.	
Size	Document Number	Rev	Rev
C	23-RESERVED	1A	1A
Date	Wednesday, April 07, 2004	Sheet	29 of 38

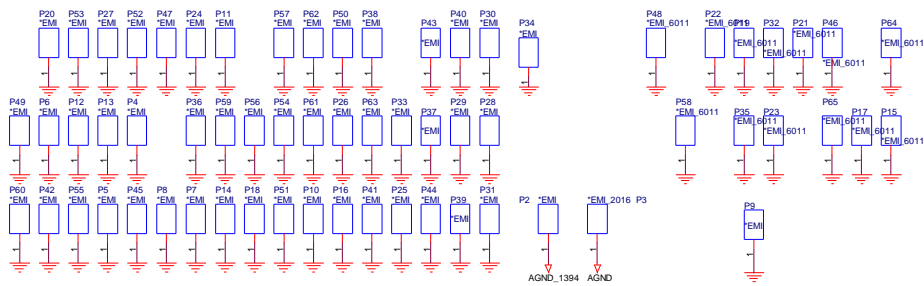
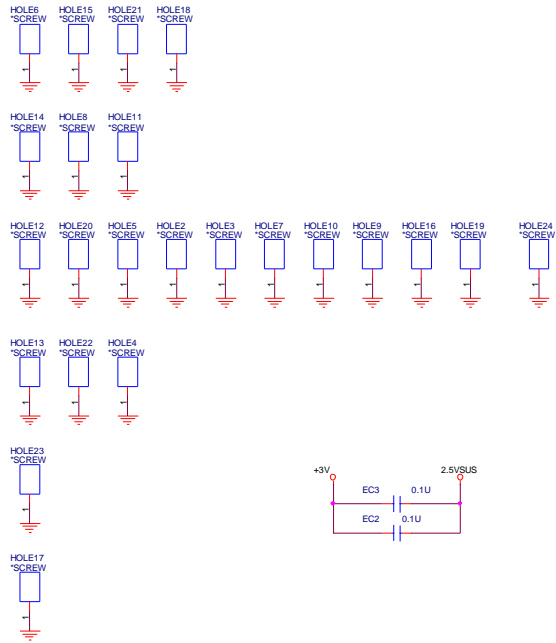



		PROJECT : KT2	
		Quanta Computer Inc.	
Size	Document Number	Rev	
C	31--PORT REPLICATOR	1A	
Date	Wednesday, April 07, 2004		Sheet 31 of 38

TOUCH PAD CONNECTOR

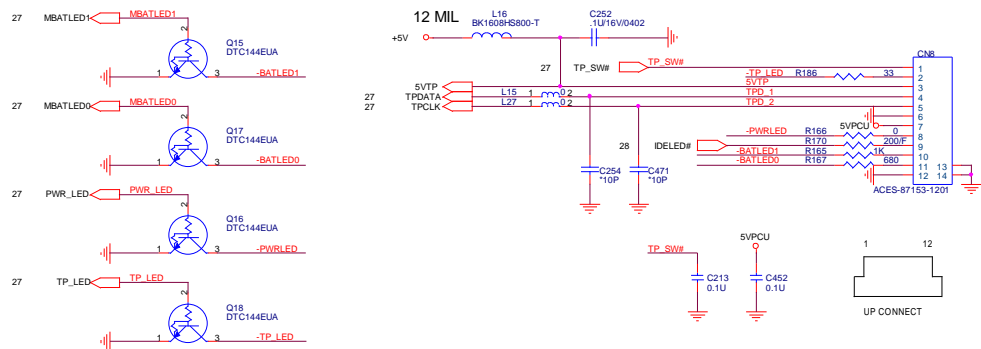

PS/2 PORT

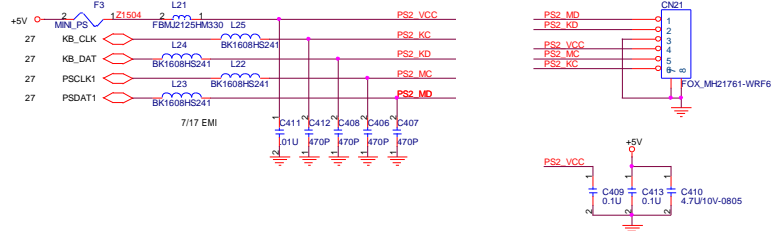

KEYBOARD CONNECTOR

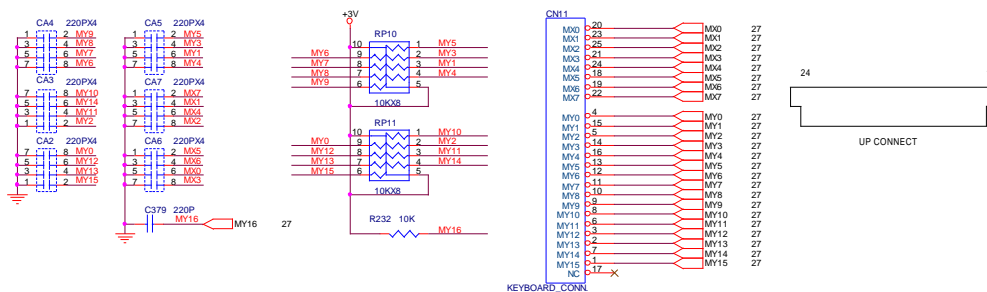

VOLUME CONTROL

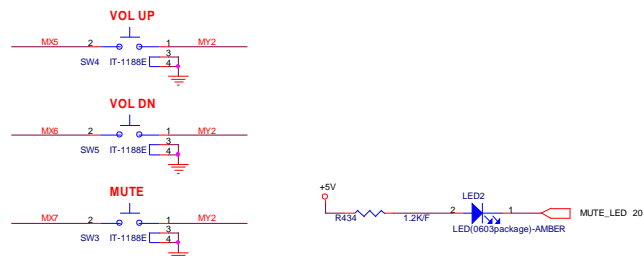

	MX0	MX1	MX2	MX3	MX4	MX5	MX6	MX7
MY2	RF	TouchPad				VOL UP	VOL DN	MUTE
MY7								
MY16	QS1	QS2	QS3	QS4	QS5			

USB PORT

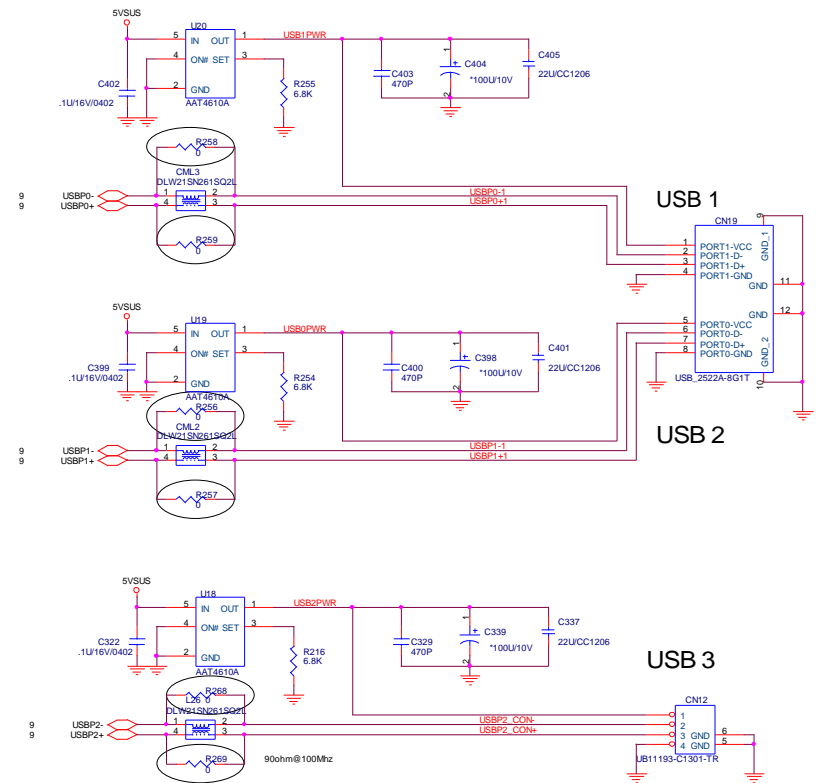

LED BOARD CON

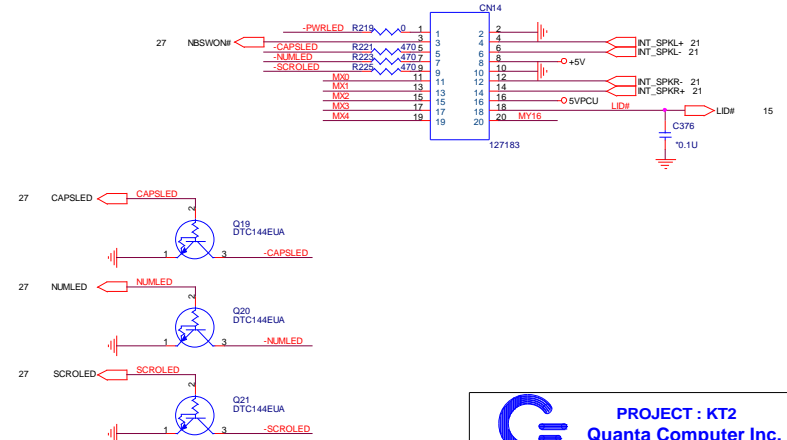

PROJECT : KT2
Quanta Computer Inc.

Size C Document Number 32--TP, KB, PS2, LEDB, KEY, USB Rev. 1/A
 Date: Wednesday, April 07, 2004 Sheet 32 of 38

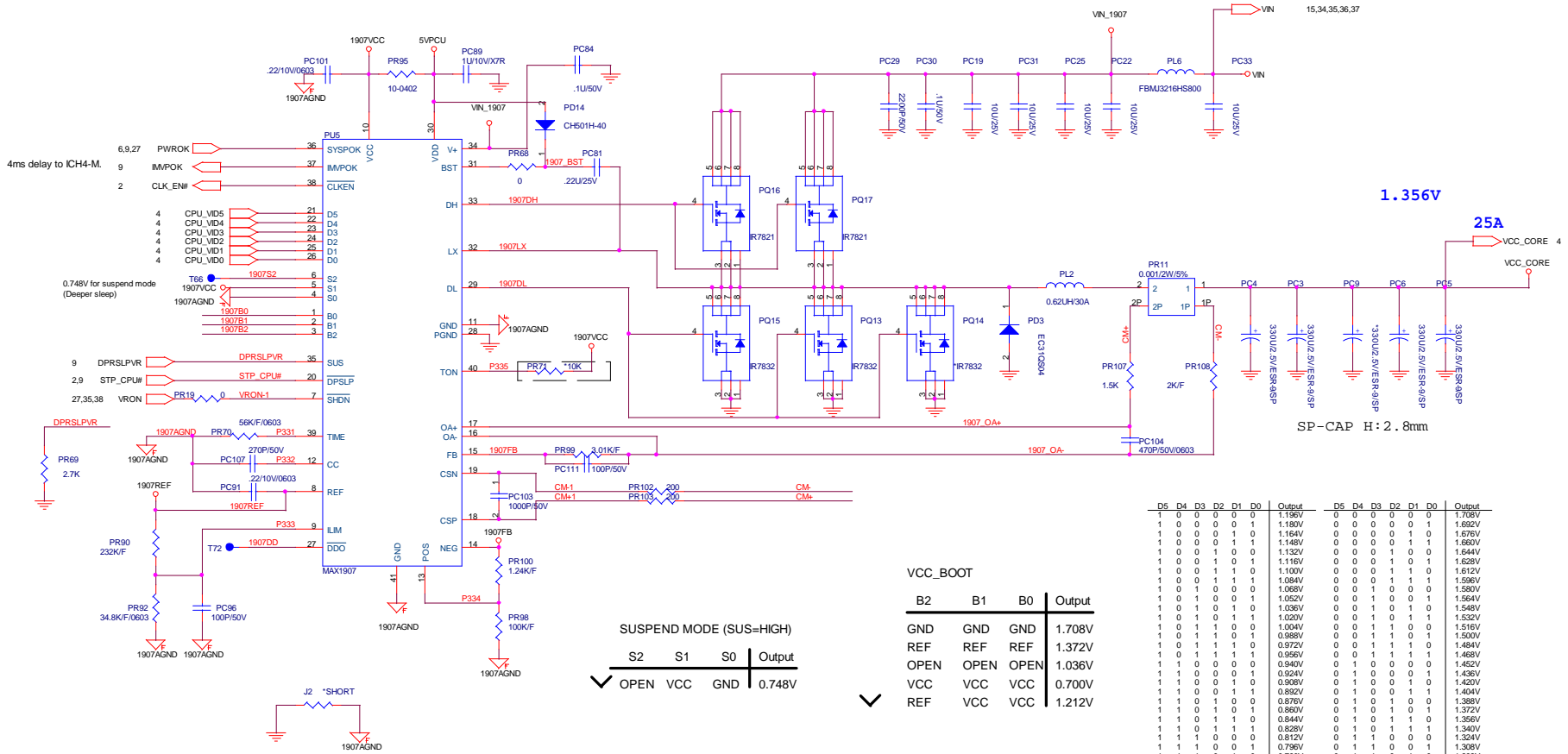

SUSPEND MODE (SUS=HIGH)

S2	S1	S0	Output
✓ OPEN	VCC	GND	0.748V

VCC_BOOT

B2	B1	B0	Output
GND	GND	GND	1.708V
REF	REF	REF	1.372V
OPEN	OPEN	OPEN	1.036V
VCC	VCC	VCC	0.700V
✓ REF	VCC	VCC	1.212V

D5	D4	D3	D2	D1	D0	Output	D5	D4	D3	D2	D1	D0	Output
1	0	0	0	0	0	1.186V	0	0	0	0	0	0	1.708V
1	0	0	0	0	1	1.180V	0	0	0	0	0	1	1.692V
1	0	0	0	1	0	1.164V	0	0	0	0	1	0	1.676V
1	0	0	0	1	1	1.148V	0	0	0	0	1	1	1.660V
1	0	0	1	0	0	1.132V	0	0	0	1	0	0	1.644V
1	0	0	1	0	1	1.084V	0	0	0	1	0	1	1.596V
1	0	0	1	1	0	1.068V	0	0	1	0	0	0	1.580V
1	0	1	0	0	0	1.052V	0	0	1	0	0	1	1.564V
1	0	1	0	0	1	1.036V	0	0	1	0	1	0	1.548V
1	0	1	0	1	0	1.020V	0	0	1	0	1	1	1.532V
1	0	1	1	0	0	1.004V	0	0	1	1	0	0	1.516V
1	0	1	1	0	1	0.988V	0	0	1	1	0	1	1.500V
1	0	1	1	1	0	0.972V	0	0	1	1	1	0	1.484V
1	0	1	1	1	1	0.956V	0	0	1	1	1	1	1.468V
1	1	0	0	0	0	0.940V	0	1	0	0	0	0	1.452V
1	1	0	0	0	1	0.924V	0	1	0	0	0	1	1.436V
1	1	0	0	1	0	0.908V	0	1	0	0	1	0	1.420V
1	1	0	0	1	1	0.892V	0	1	0	0	1	1	1.404V
1	1	0	1	0	0	0.876V	0	1	0	1	0	0	1.388V
1	1	0	1	0	1	0.860V	0	1	0	1	0	1	1.372V
1	1	0	1	1	0	0.844V	0	1	0	1	0	1	1.356V
1	1	0	1	1	1	0.828V	0	1	0	1	1	1	1.340V
1	1	1	0	0	0	0.812V	0	1	1	0	0	0	1.324V
1	1	1	0	0	1	0.796V	0	1	1	0	1	0	1.308V
1	1	1	0	1	0	0.780V	0	1	1	0	1	0	1.292V
1	1	1	0	1	1	0.764V	0	1	1	0	1	1	1.276V
1	1	1	1	0	0	0.748V	0	1	1	1	0	0	1.260V
1	1	1	1	0	1	0.732V	0	1	1	1	0	1	1.244V
1	1	1	1	1	0	0.716V	0	1	1	1	1	0	1.228V
1	1	1	1	1	1	0.700V	0	1	1	1	1	1	1.212V

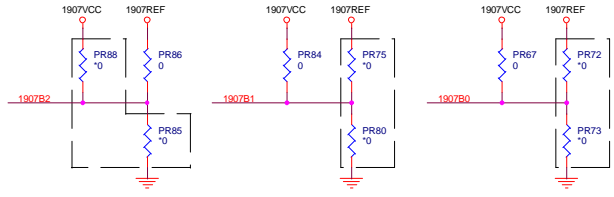

Title		
<Title>		
Size	Document Number	Rev
Customer/Doc>		<Rev/Code>
Date:	Wednesday, April 07, 2004	Sheet 33 of 38

BATTERY CHARGER

ADAPTER 18.5V 65W 3.51A

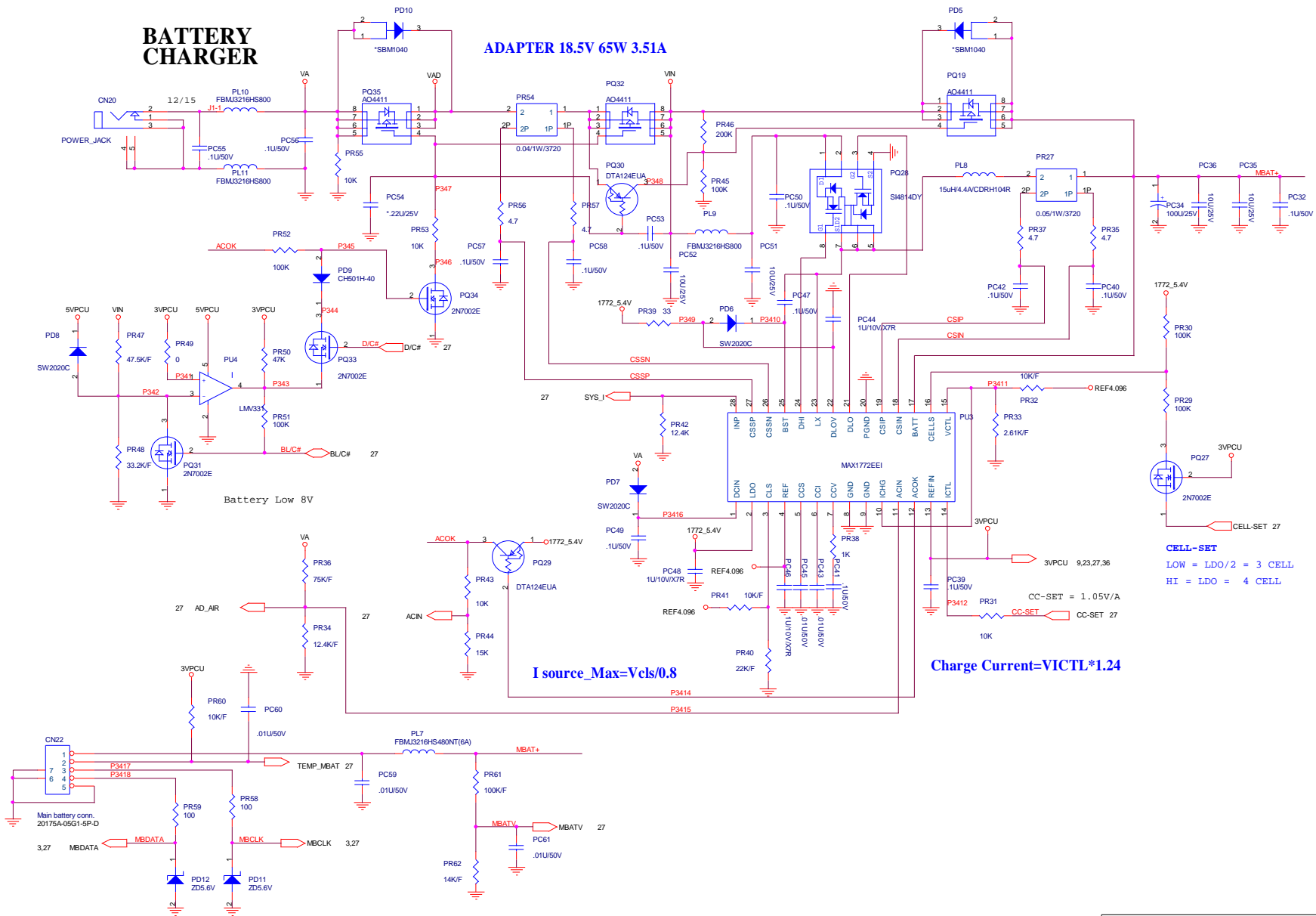

Battery Low 8V

$I_{source_Max} = V_{cls} / 0.8$

$Charge\ Current = VICTL * 1.24$

CELL-SET
 LOW = LDO/2 = 3 CELL
 HI = LDO = 4 CELL

Title	<Title>	
Size	Document Number	Rev
	Custom/Doc>	<Rev/Code>
Date:	Wednesday, April 07, 2004	Sheet 34 of 38

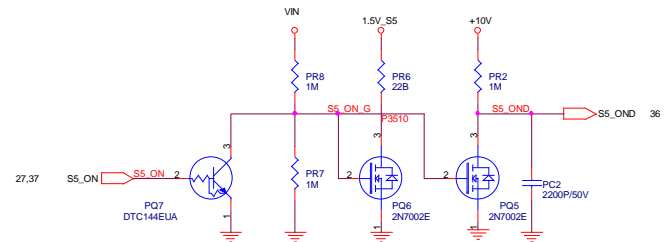
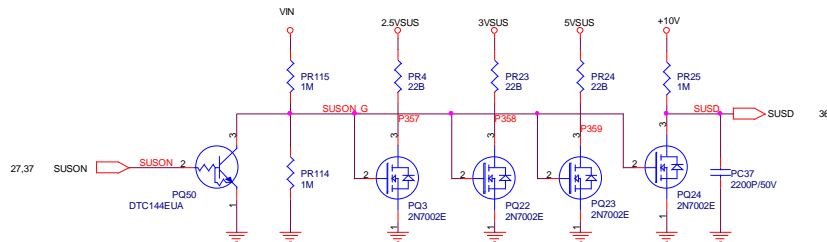
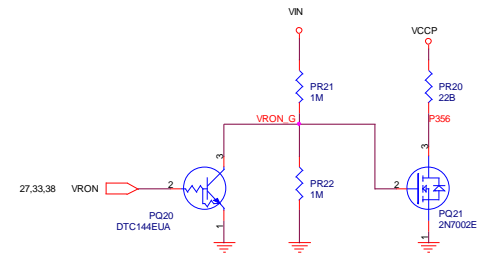
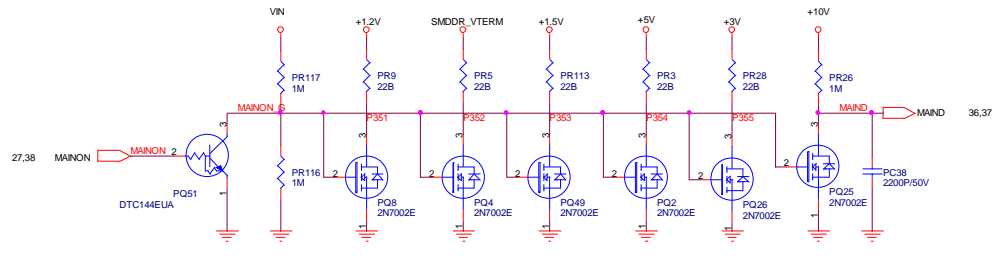

Title		
<Title>		
Size	Document Number	Rev
Custom/Doc		<Rev Code>
Date:	Wednesday, April 07, 2004	Sheet 35 of 38

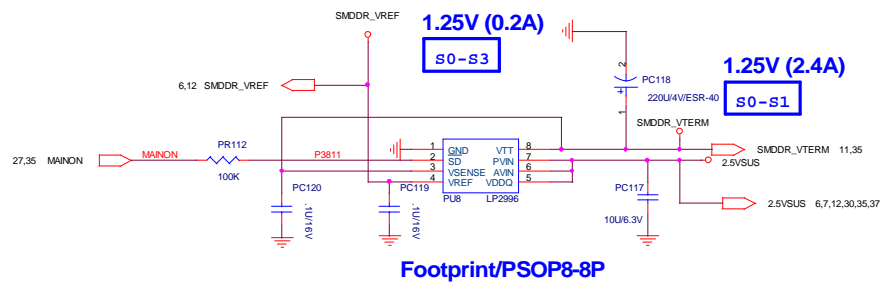
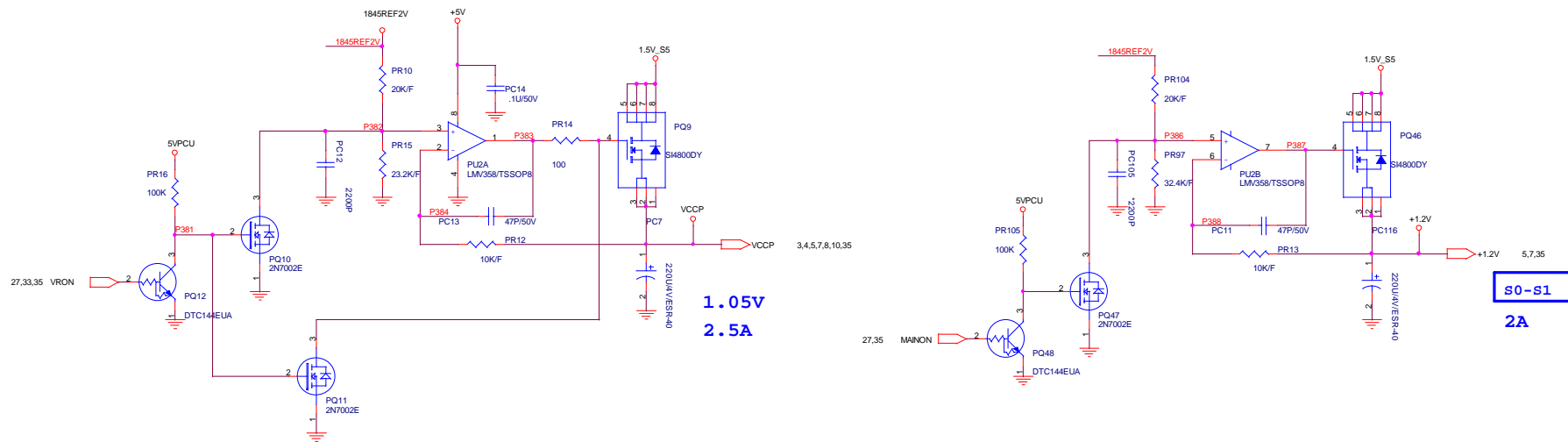

Title		
<Title>		
Size	Document Number	Rev
Custom-Doc>		<Rev-Code>
Date:	Wednesday, April 07, 2004	Sheet 38 of 38