

DosXX Dunkel 1.0

MV1_BUILD

2007.02.28

DATE	CHANGE NO.	REV

DRAWER	EE	DATE	POWER	DATE	INVENTEC			
DESIGN					TITLE DD1.0			
CHECK								
RESPONSIBLE								
SIZE =	3	VER :			SIZE A3	CODE CS	DOC. NUMBER	REV A02
FILE NAME :	XXXX-XXXXXX-XX				Model No			
P/N	XXXXXXXXXXXX				SHEET	1	OF	60

TABLE OF CONTENTS

PAGE	PAGE	PAGE
5- DC& BATTERY CHARGER	28- DDR2-DIMM0	52-MINI CARD(WWAN/WLAN)& SIM CARD
6- SELECT & BATTERY CONN	29- DDR2-DIMM1	53-ODD extension board
7- SYSTEM POWER(3V/5V)	30- DDR2-DAMPING	54- DOCKING CONN
8- SYSTEM POWER(+V1.8/+V1.25S)	31- CRT& SVIDEO CONN	55- LED/SWITCH CONN
9- GRAPHIC POWER(+VGFX_CORE)	32- LCD CONN	56- SCREW
10- SYSTEM POWER(+VCCP/+V1.5S)	33- ICH8-1	57- SWITCH DOUGHTER BOARD
11- CPU POWER(VCC_CORE)	34- ICH8-2	58- 58- Finger Print board
12- DDR TERMINATION VOLTAGE	35- ICH8-3	59- 5 IN 1 CONTROLLER(Northstar)
13- POWER(SLEEP)	36- ICH8-4	60- 5 IN 1 CONNECTOR(Northstar)
14- POWER(SEQUENCE)	37- ICH8-5	
15- CLOCK_GENERATOR	38- HDD CONN	
16- MEROM-1	39- ODD CONN	
17- MEROM-2	40- USB CONN/USB(DB)	
18- MEROM-3	41- FINGER PRINT&BlueTooth	
19- MEROM-4	42- TPM V1.2	
20- THERMAL&FAN CONTROLLER	43- FWH/SPI/HDD PROTECTION	
21- Crestline-1	44- KBC	
22- Crestline-2	45- INT.KBC/POINT DEVICES	
23- Crestline-3-HOST	46- SUPER I/O	
24- Crestline-4-DDR2	47- DAUGHTER BOARD CONN	
25- Crestline-5-POWER	48- 5 IN 1 CONTROLLER	
26- Crestline-6-POWER	49- 5 IN 1 CONNECTOR	
27- Crestline-7-POWER	50- LAN INTERFACE-1	
	51- LAN RJ45 CONN	

INVENTEC

TITLE *DD1.0*

SIZE A3	CODE CS	DOC. NUMBER <i>Model No</i>	REV A02
-------------------	-------------------	--------------------------------	-------------------

CHANGE by *MORRIS CHANG* 28-Feb-2007

SHEET 2 OF 60

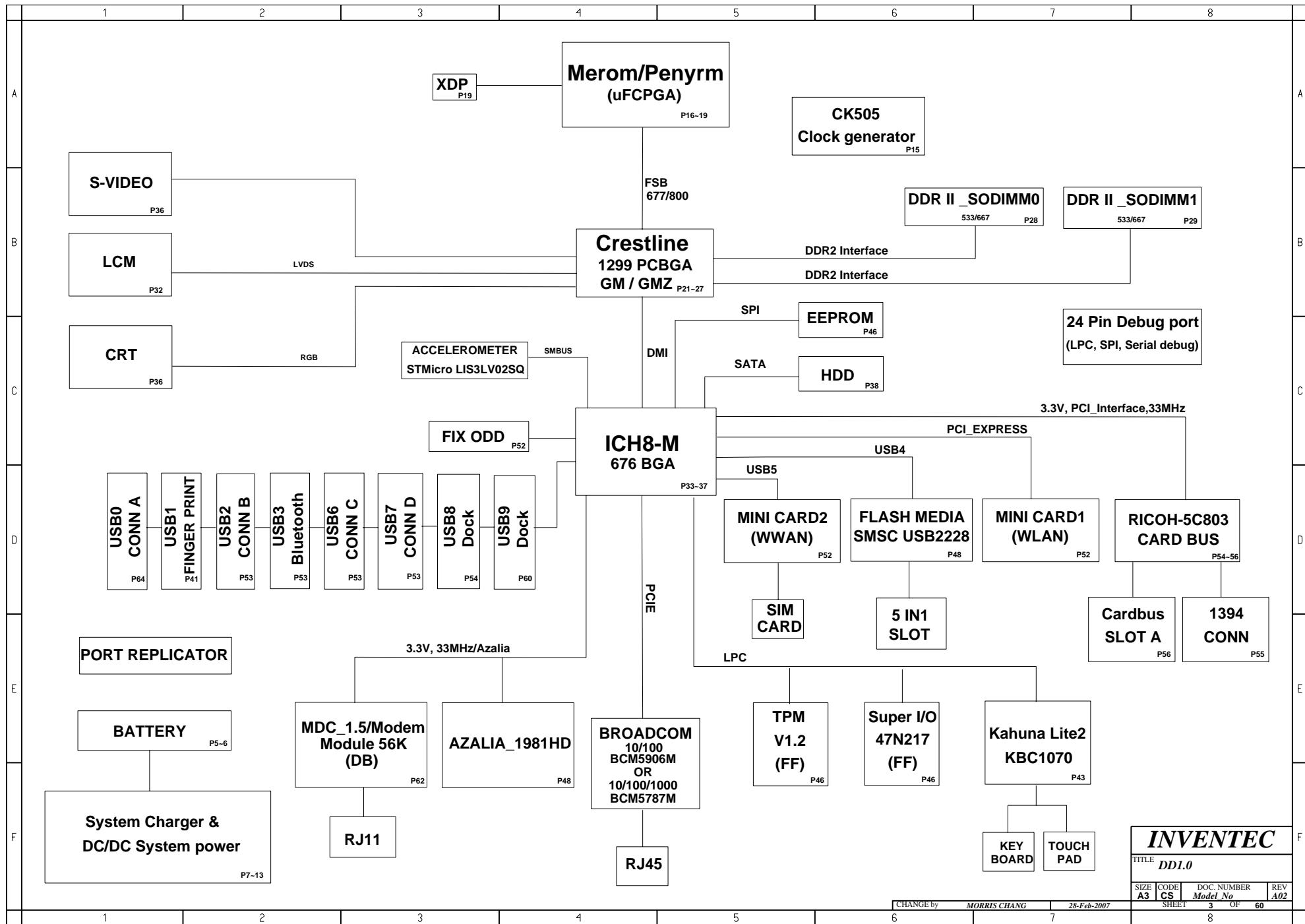

INVENTEC			
TITLE DD1.0			
SIZE A3	CODE CS	DOC. NUMBER <i>Model No</i>	REV A02
CHANGE by MORRIS CHANG		28-Feb-2007	
SHEET 3		OF 60	

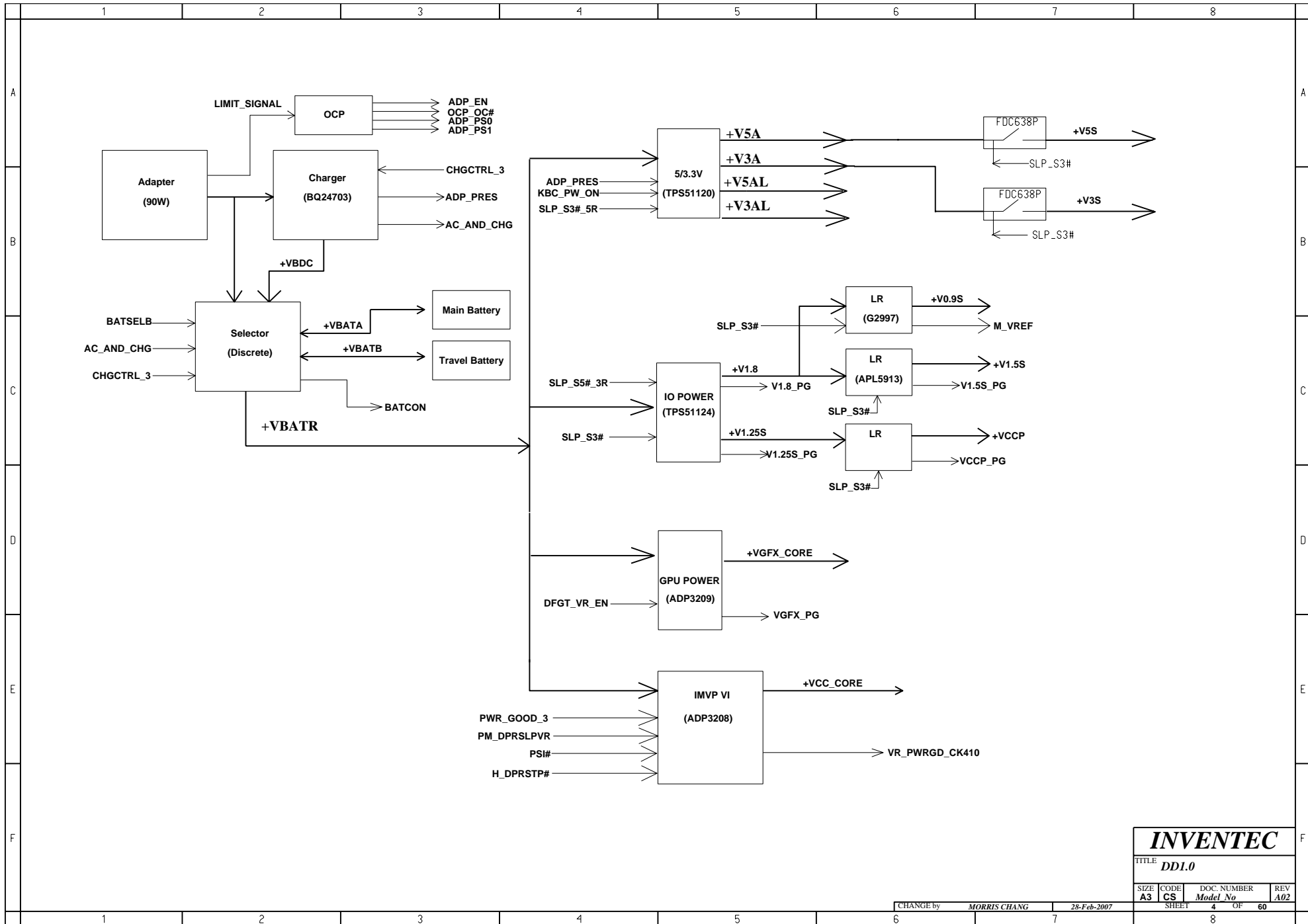

INVENTEC

TITLE **DD1.0**

SIZE A3	CODE CS	DOC. NUMBER Model No	REV A02
----------------	----------------	-----------------------------	----------------

CHANGE by **MORRIS CHANG** 28-Feb-2007

SHEET **4** OF **60**

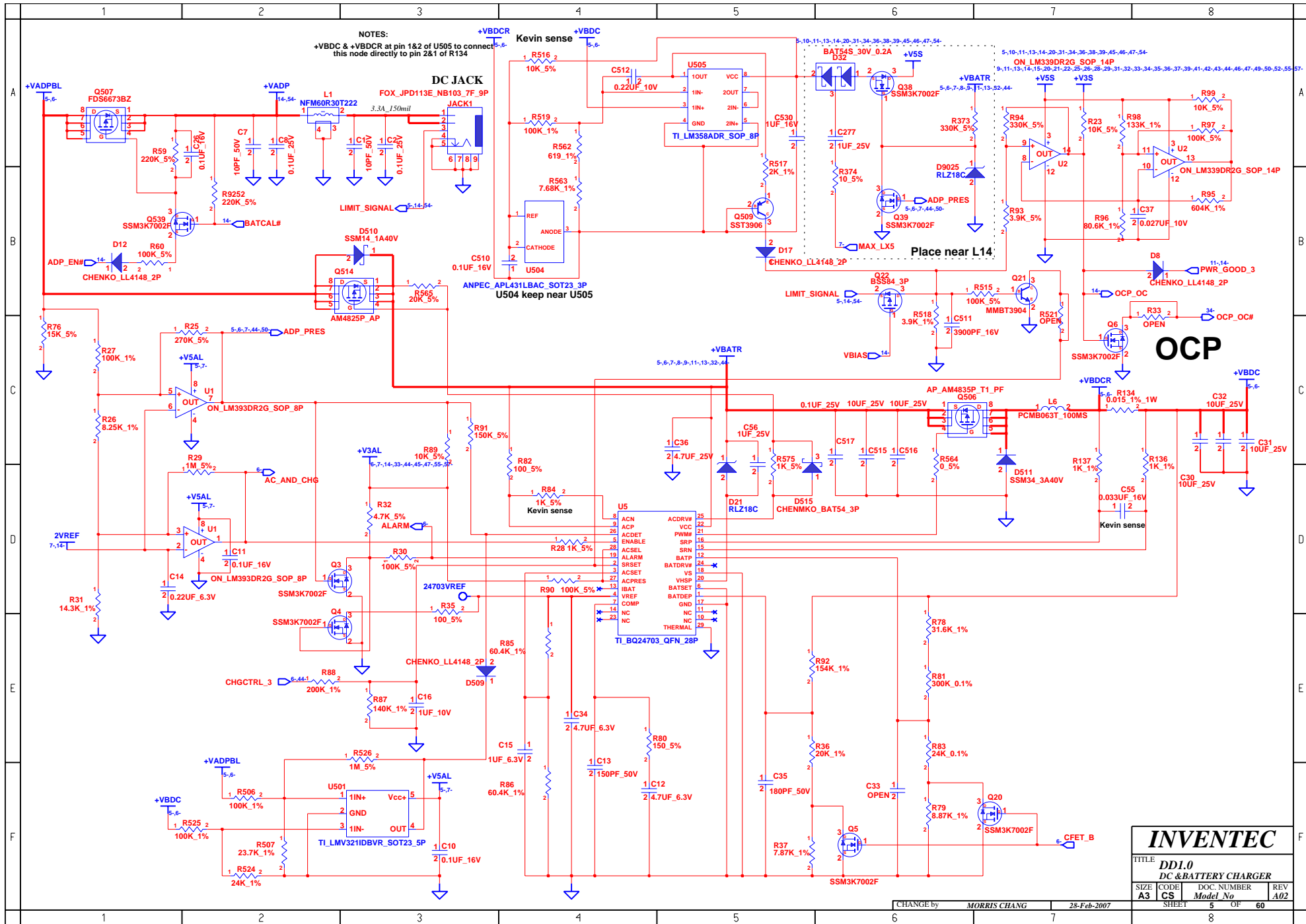

INVENTEC			
TITLE: DD1.0 DC & BATTERY CHARGER			
SIZE: A3	CODE: CS	DOC. NUMBER: Model No	REV: A02
CHANGE by: MORRIS CHANG	28-Feb-2007	SHEET: 5	OF: 60

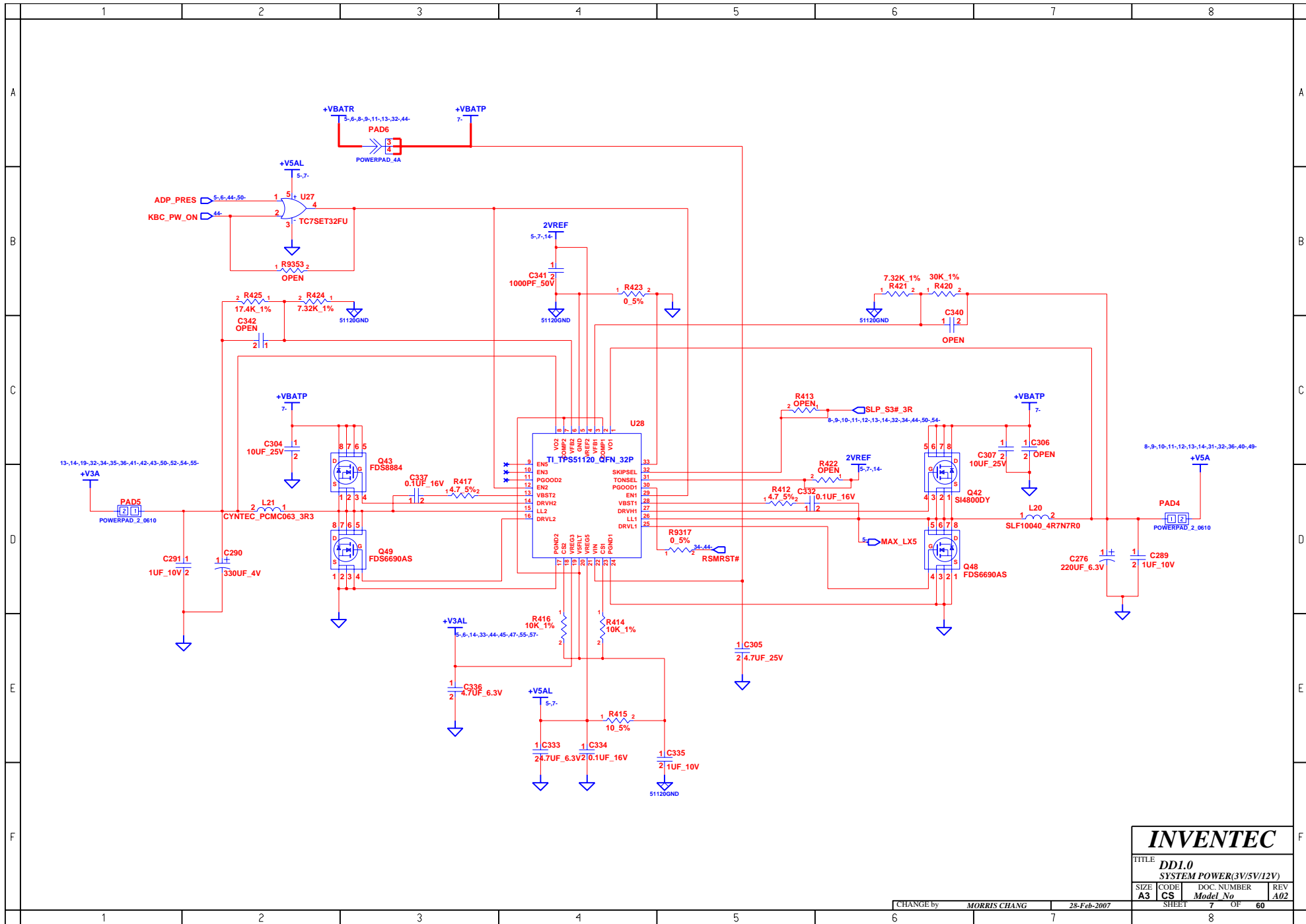

INVENTEC			
TITLE DDI.0 SYSTEM POWER(3V/5V/12V)			
SIZE A3	CODE CS	DOC. NUMBER Model No	REV A02

CHANGE by MORRIS CHANG 28-Feb-2007 SHEET 7 OF 60

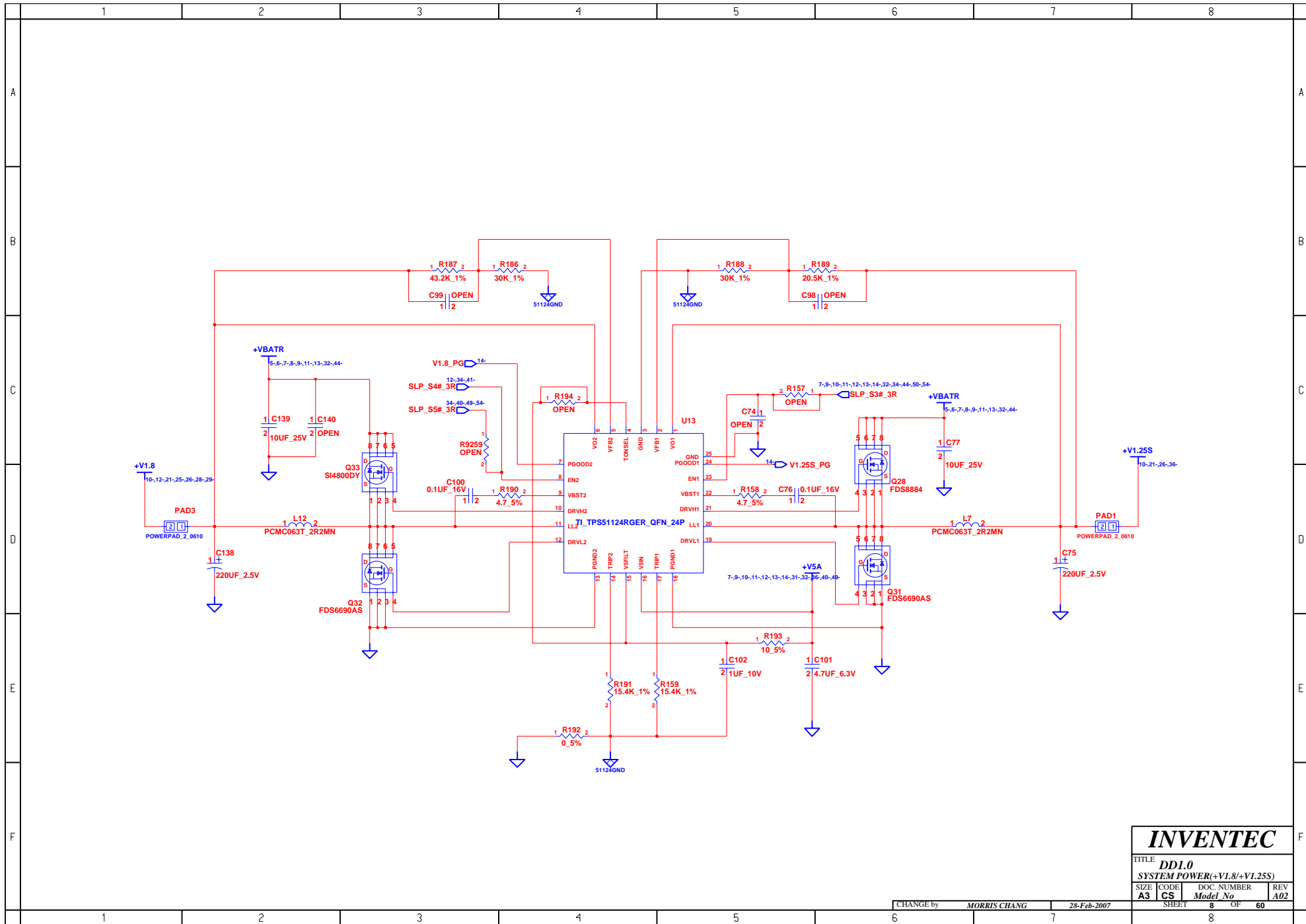

INVENTEC

TITLE
DD1.0
SYSTEM POWER(+V1.8/+V1.25S)

SIZE A3	CODE CS	DOC. NUMBER Model No	REV A02
-------------------	-------------------	-------------------------	-------------------

CHANGE by **MORRIS CHANG** 28-Feb-2007 SHEET 8 OF 60

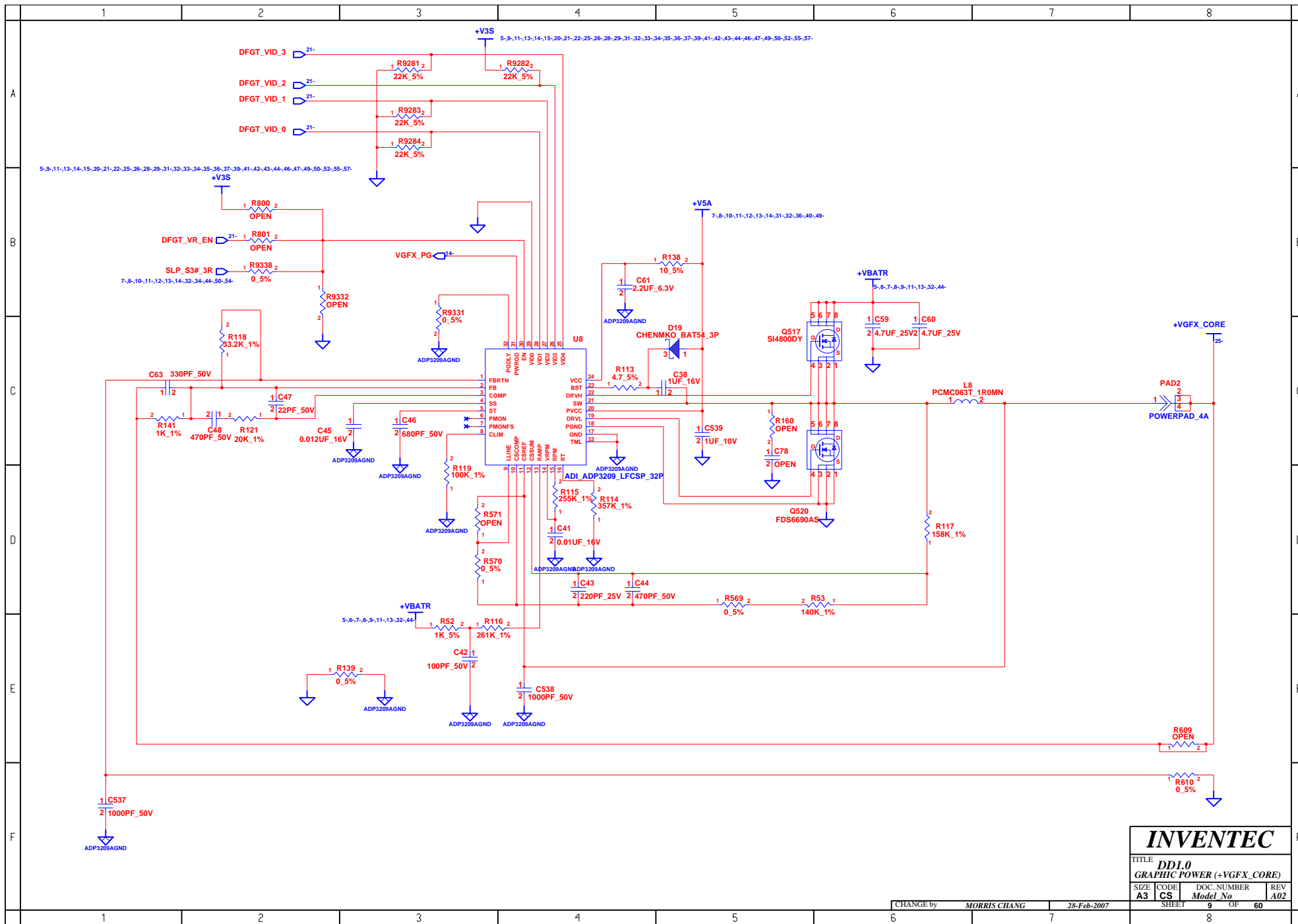

INVENTEC			
TITLE DDL.0			
GRAPHIC POWER (+VGFX_CORE)			
SIZE A3	CODE CS	DOC. NUMBER Model No	REV A02
CHANGE by MORRIS CHANG		28-Feb-2007	
SHEET 9		OF 60	

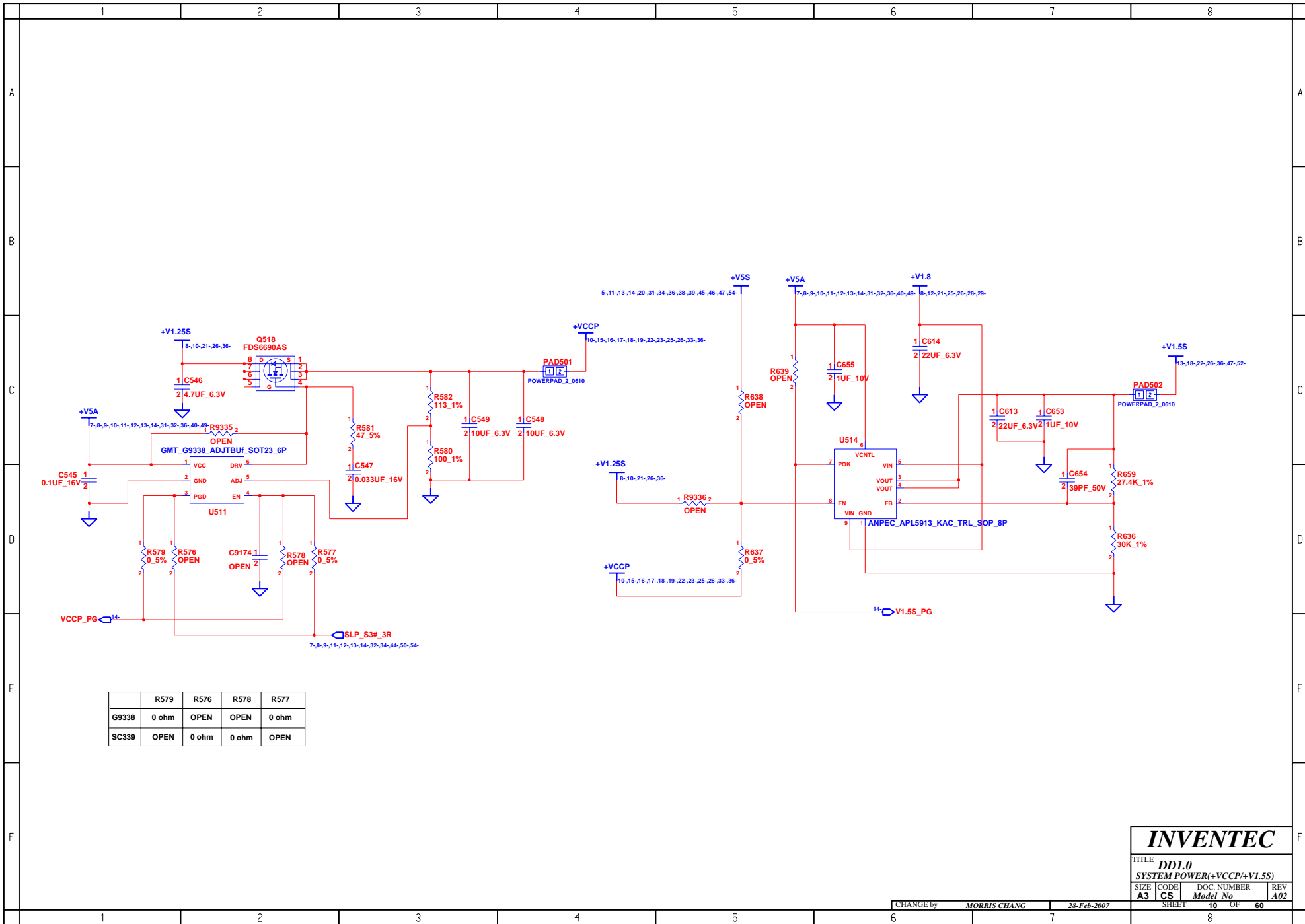

INVENTEC

TITLE **DD1.0**
SYSTEM POWER(+VCCP/+V1.5S)

SIZE A3	CODE CS	DOC. NUMBER Model No	REV A02
----------------	----------------	-----------------------------	----------------

CHANGE by **MORRIS CHANG** 28-Feb-2007

SHEET **10** OF **60**

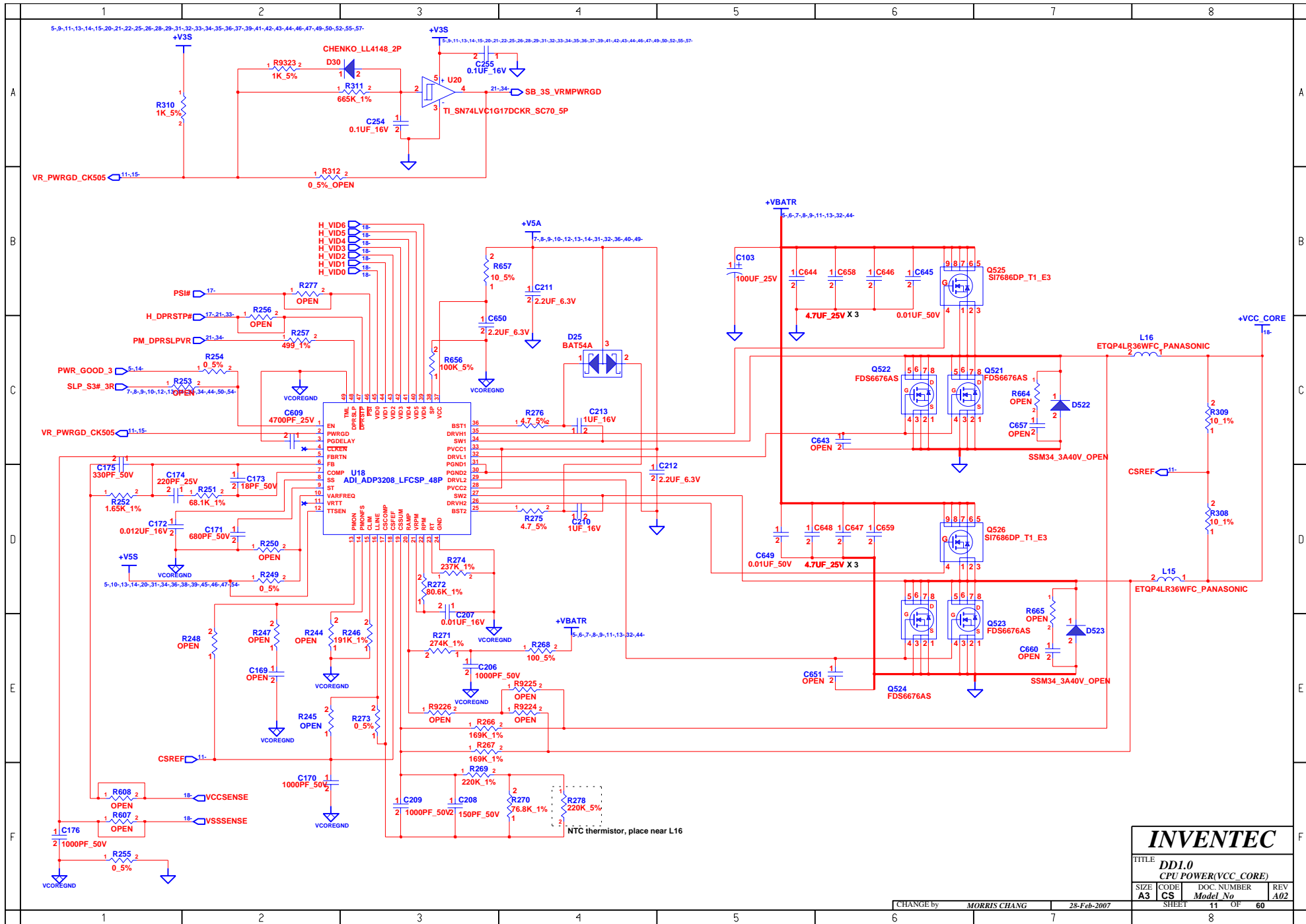

INVENTEC			
TITLE DDI.0 CPU POWER(VCC_CORE)			
SIZE A3	CODE CS	DOC. NUMBER Model No	REV A02
CHANGE by MORRIS CHANG		28-Feb-2007	
SHEET 11		OF 60	

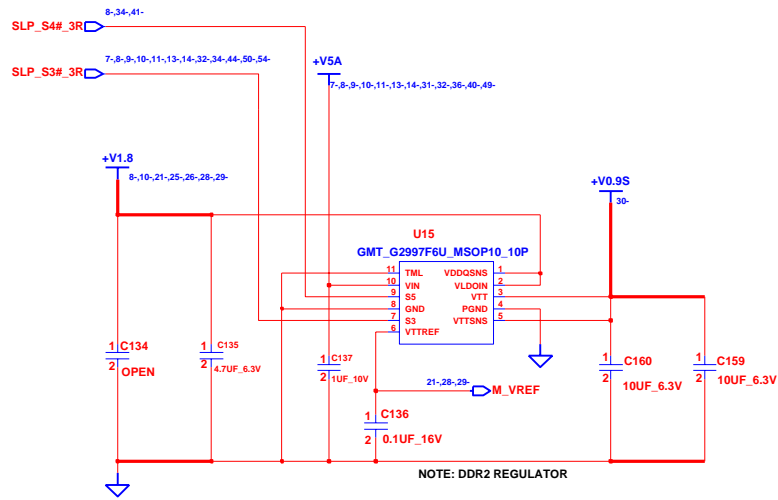

INVENTEC

TITLE			
DD1.0			
DDR TERMINATION VOLTAGE			
SIZE	CODE	DOC. NUMBER	REV
A3	CS	Model No	A02

CHANGE by MORRIS CHANG 28-Feb-2007

SHEET 12 OF 60

1	2	3	4	5	6	7	8
A							A
B							B
C							C
D							D
E							E
F							F
1	2	3	4	5	6	7	8

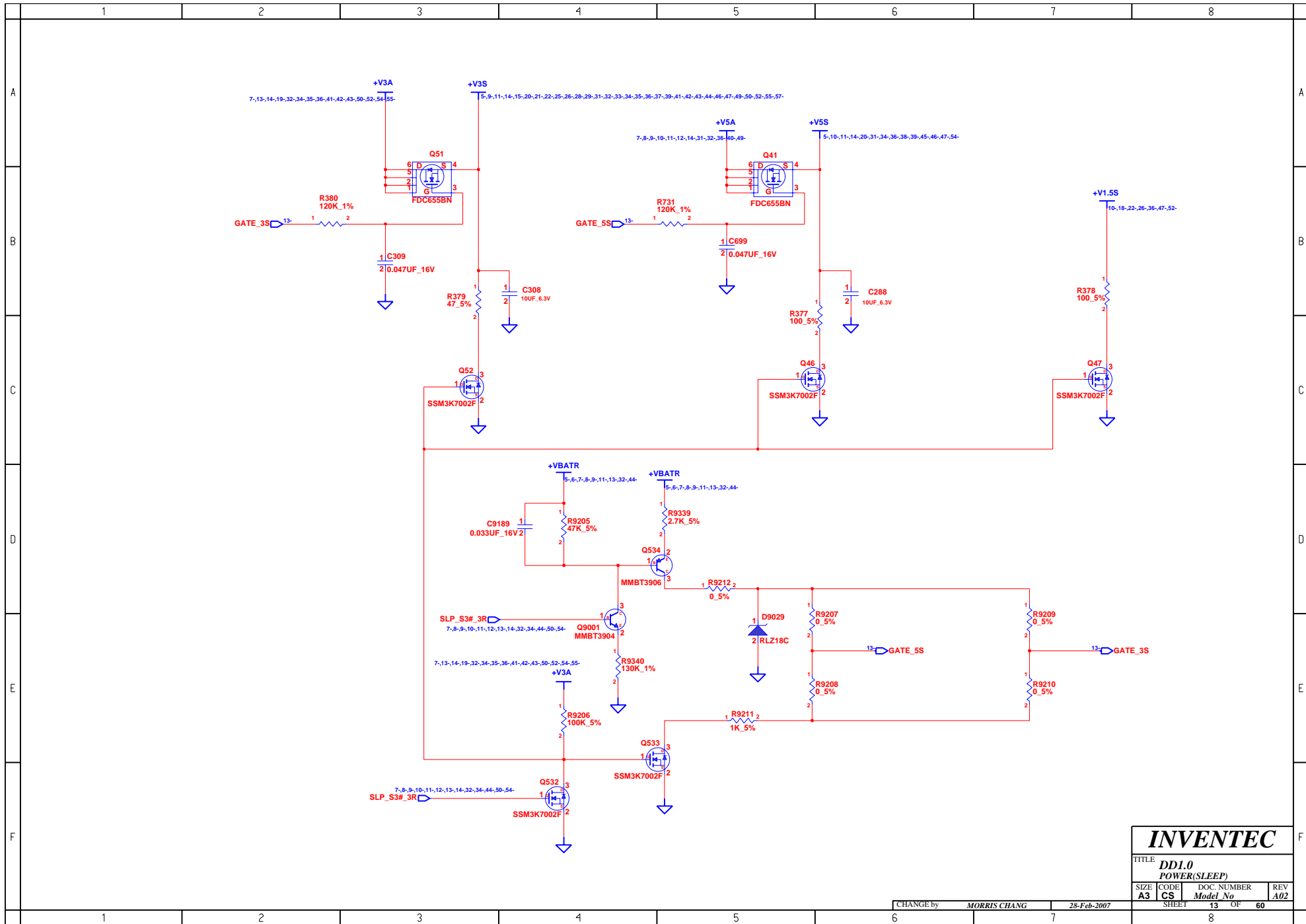

INVENTEC

TITLE			
DDI.0			
POWER(SLEEP)			
SIZE	CODE	DOC. NUMBER	REV
A3	CS	Model No	A02

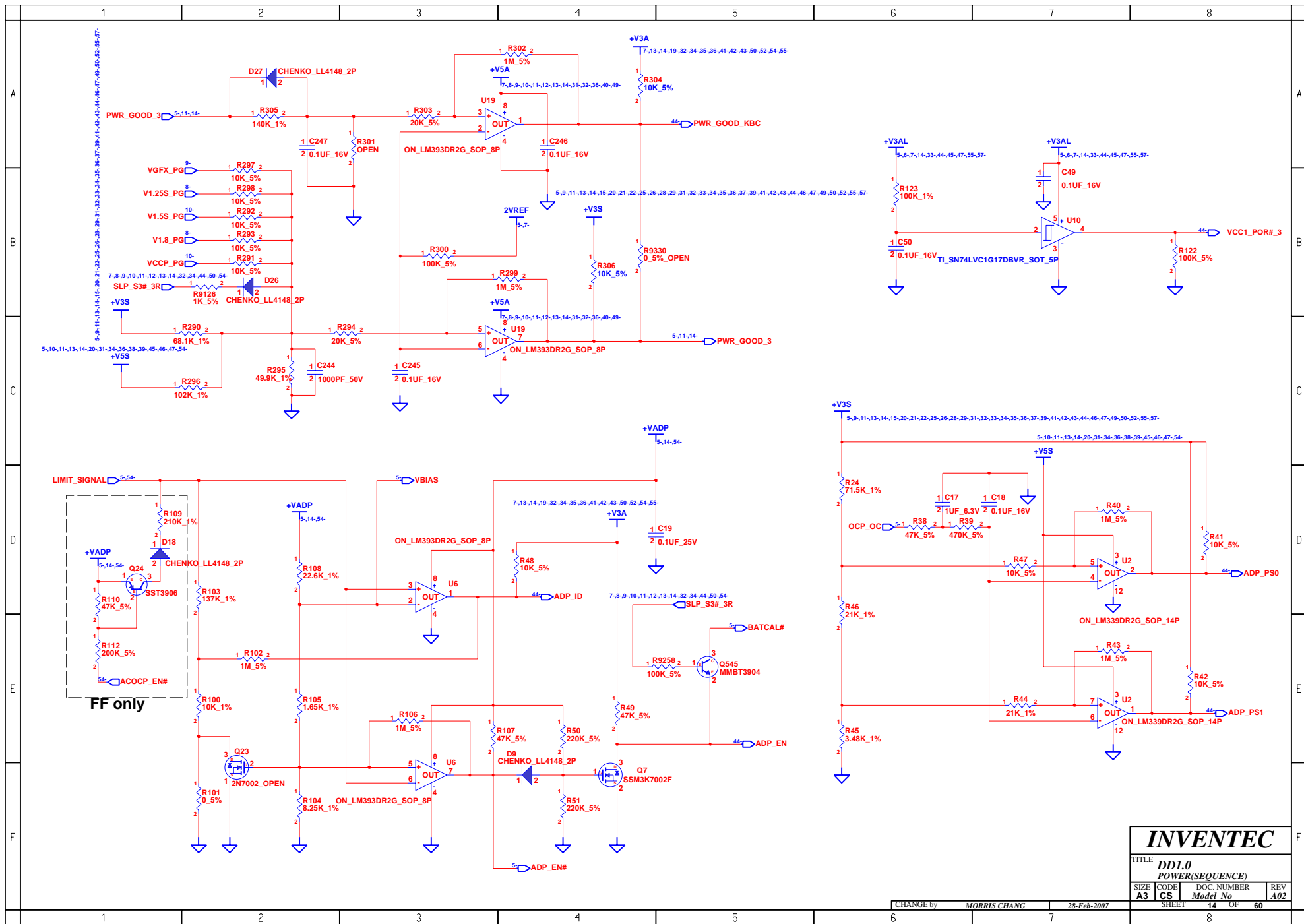

INVENTEC			
TITLE DD1.0 POWER(SEQUENCE)			
SIZE A3	CODE CS	DOC. NUMBER Model No	REV A02
CHANGE by MORRIS CHANG		28-Feb-2007	
SHEET 14		OF 60	

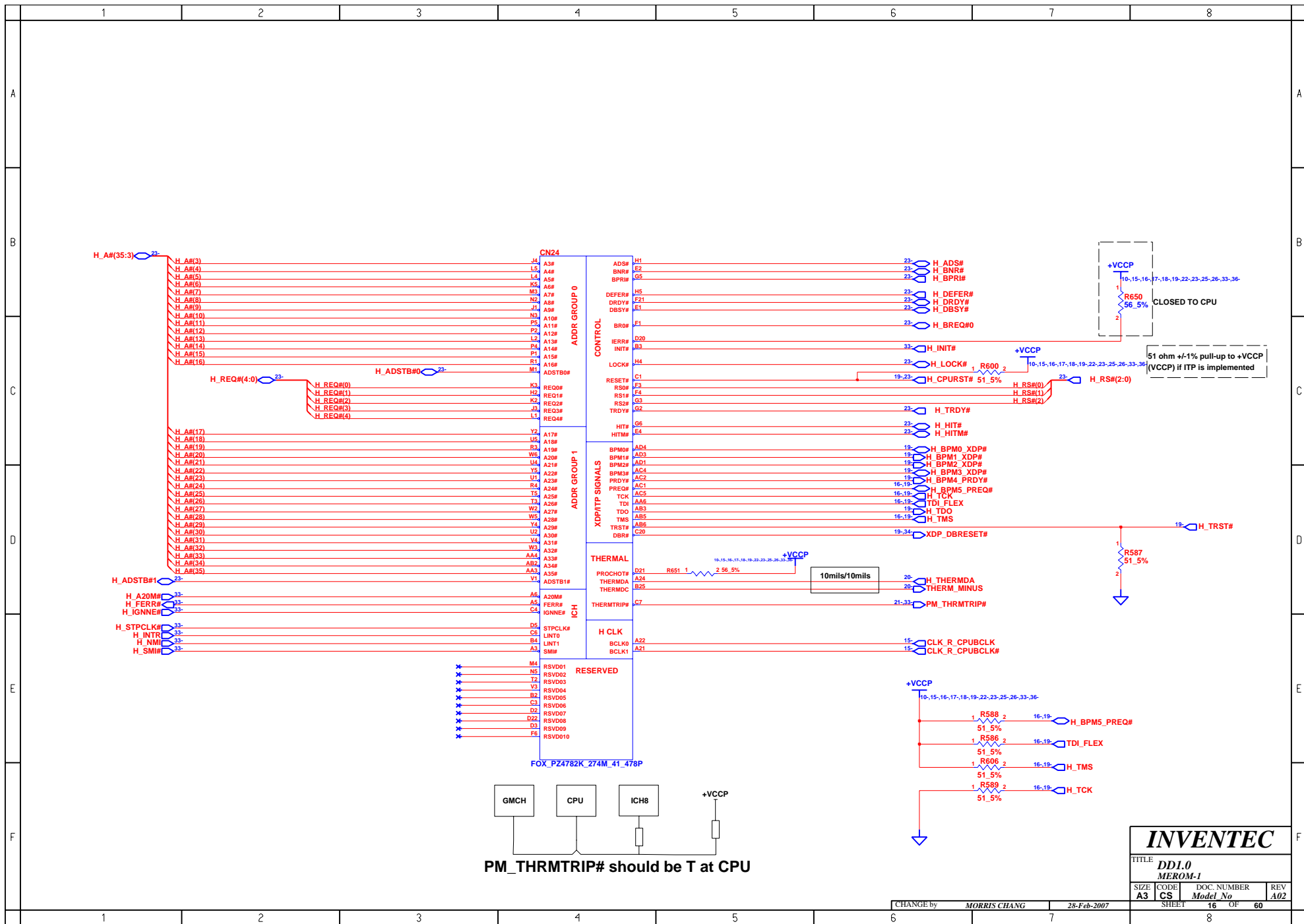

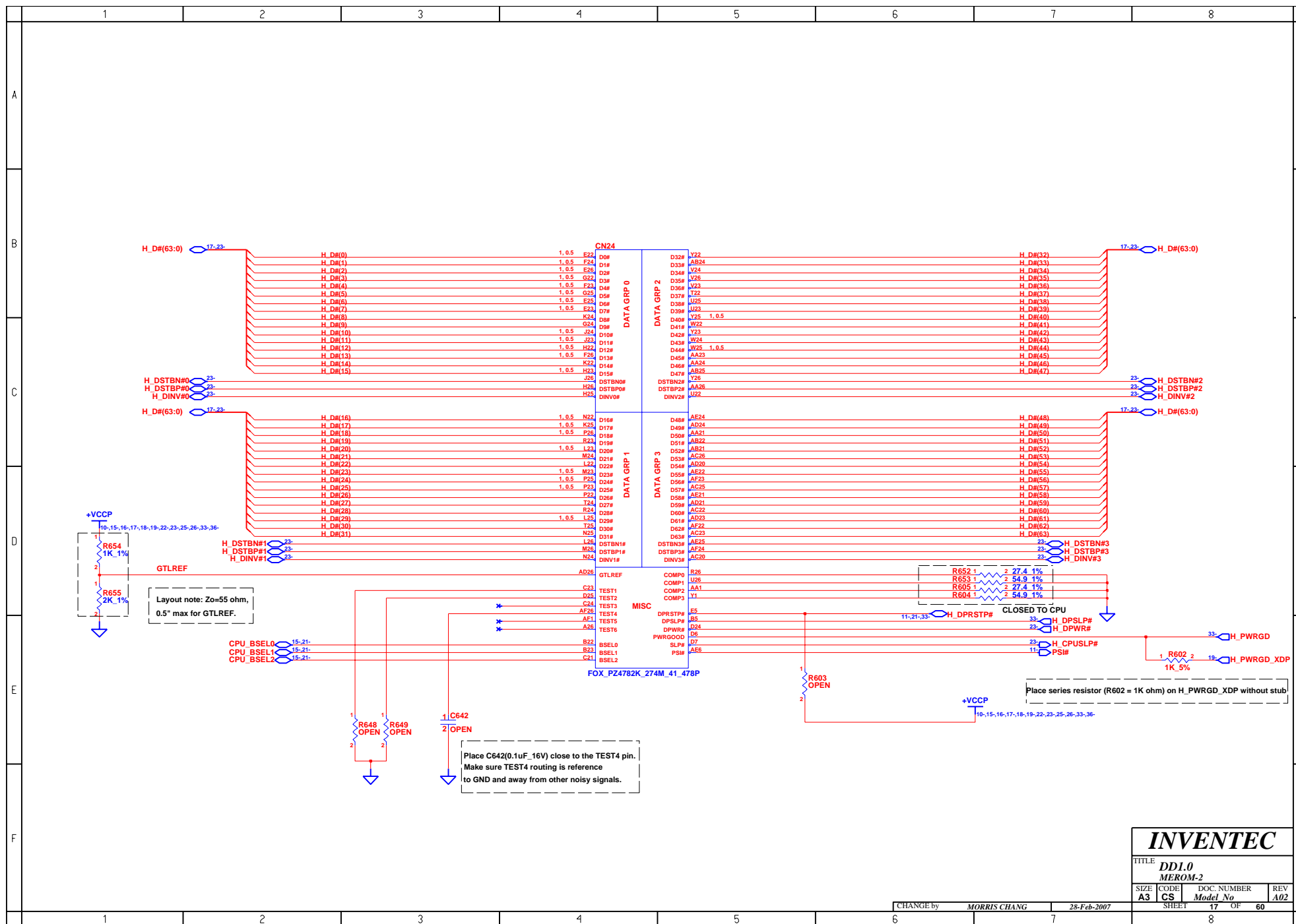

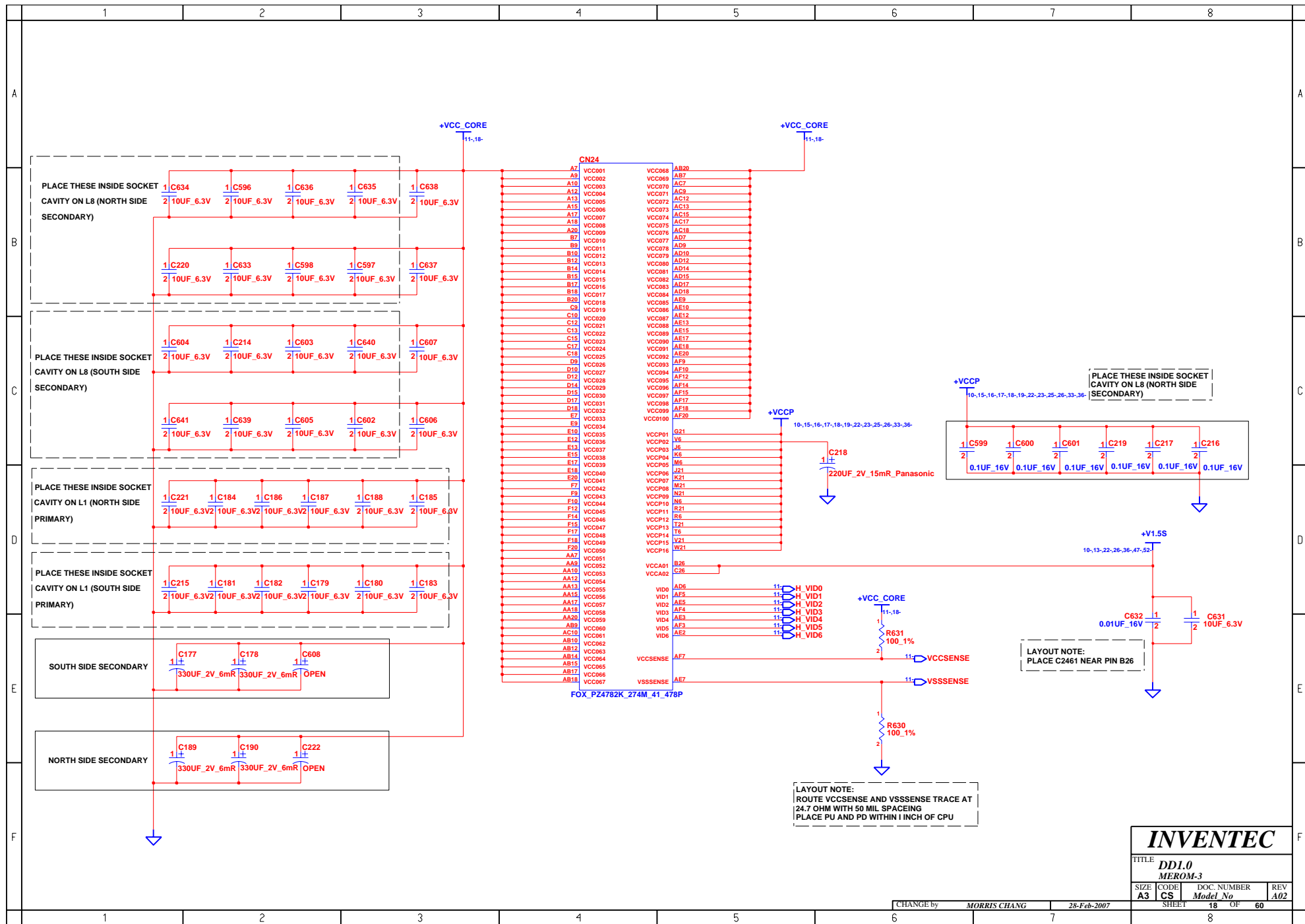

INVENTEC				
TITLE				
DD1.0				
MEROM-3				
SIZE	CODE	DOC. NUMBER	REV	
A3	CS	Model No	18	A02

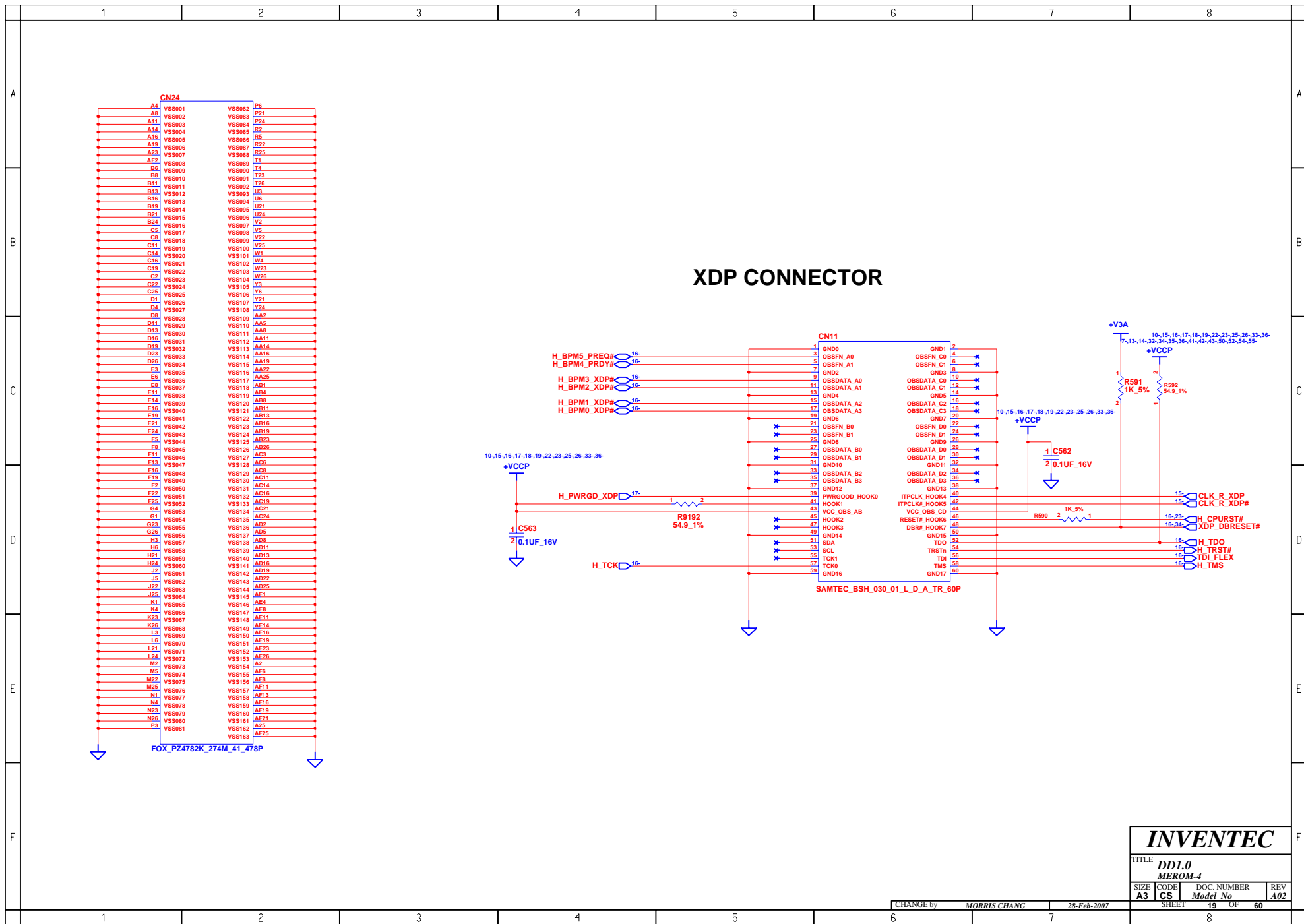

INVENTEC			
TITLE DD1.0 MEROM-4			
SIZE A3	CODE CS	DOC. NUMBER <i>Model No</i>	REV A02
CHANGE by <i>MORRIS CHANG</i>		28-Feb-2007	
SHEET 19		OF 60	

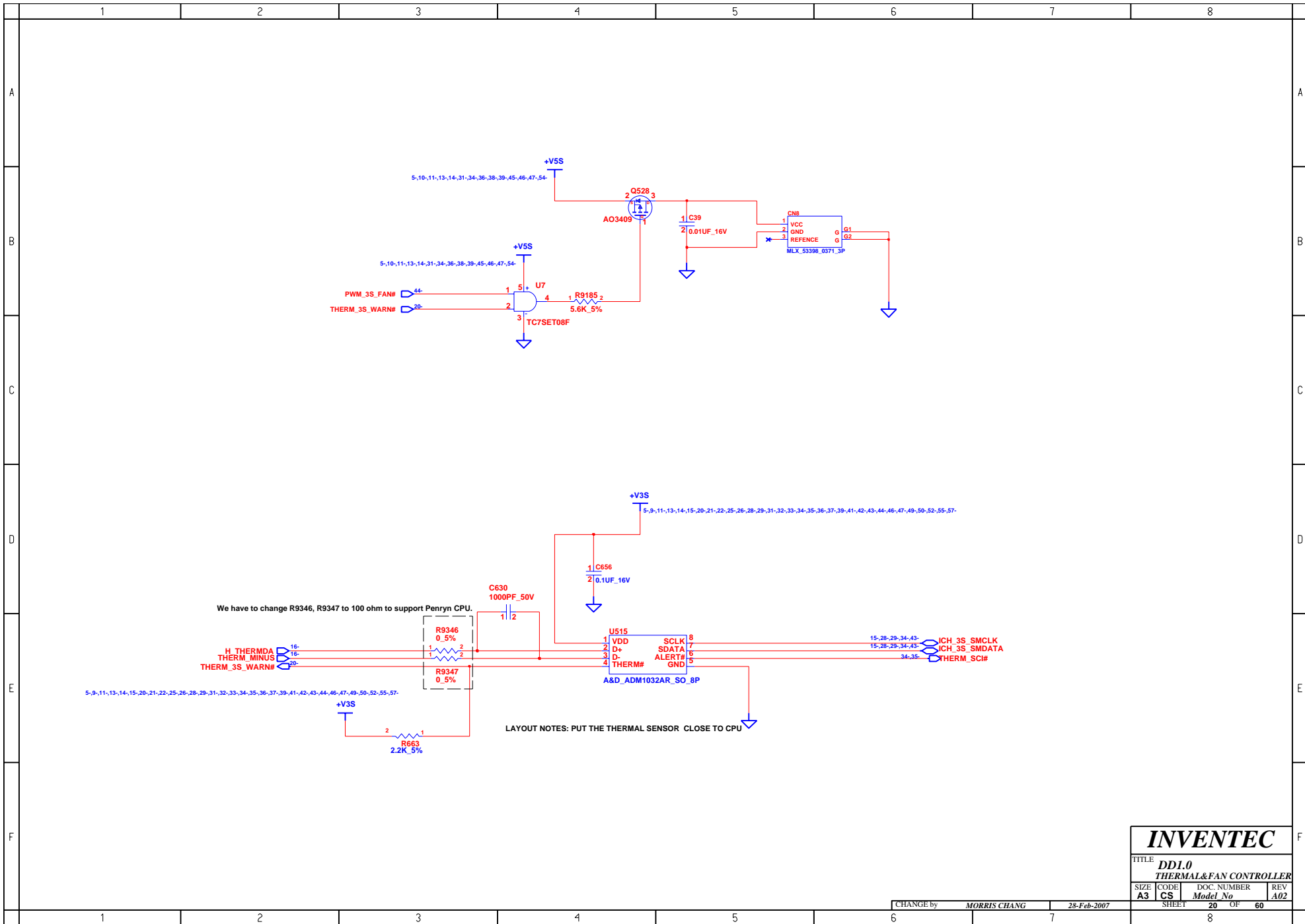

INVENTEC			
TITLE DD1.0			
THERMAL&FAN CONTROLLER			
SIZE A3	CODE CS	DOC. NUMBER Model No	REV A02
CHANGE by MORRIS CHANG		28-Feb-2007	
SHEET 20		OF 60	

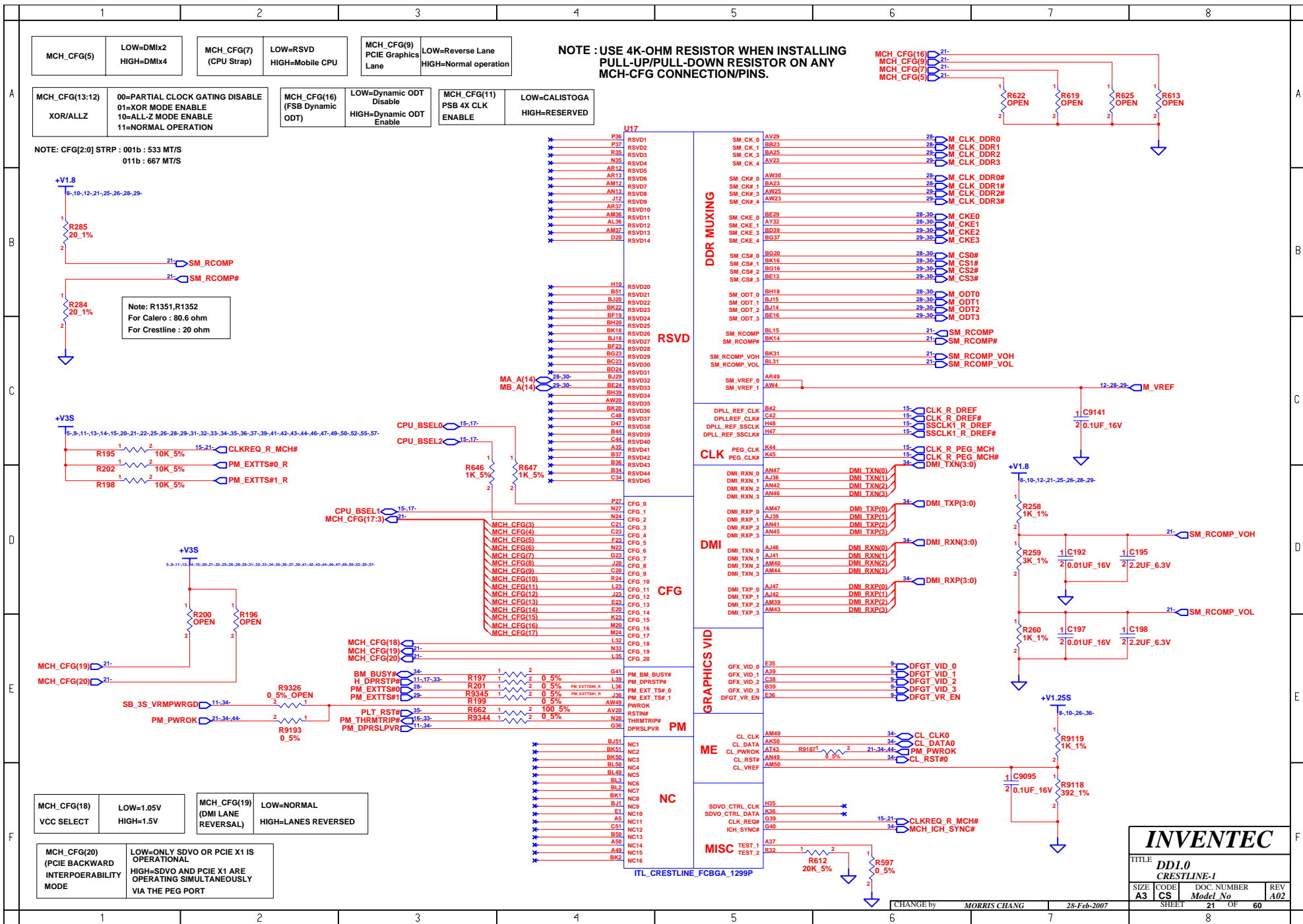

INVENTEC

TITLE: **DDI.0**
CRESTRLINE-1

SIZE	CODE	DOC. NUMBER	REV
A3	CS	Model No	A02

SHEET 21 OF 60

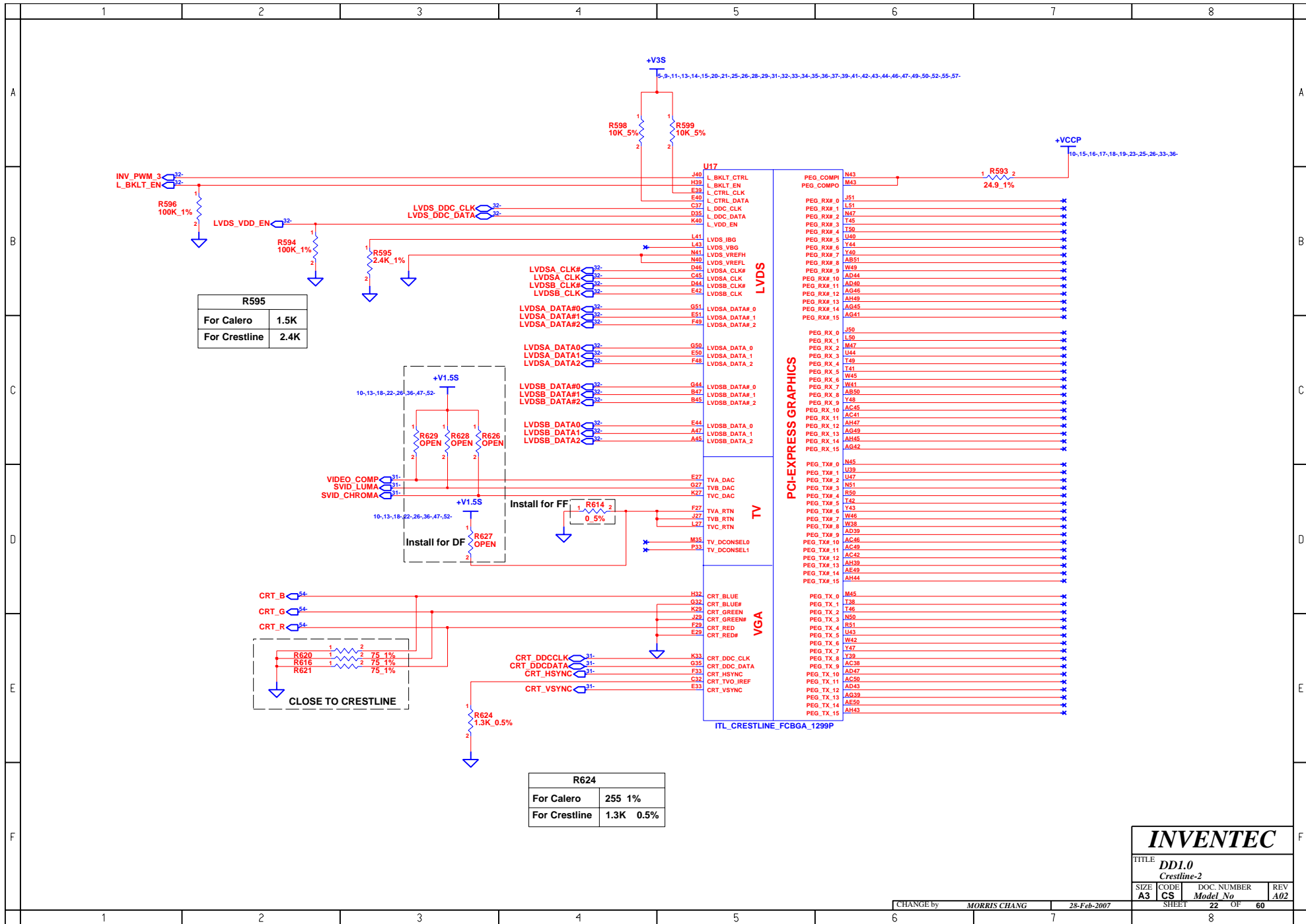

INVENTEC

TITLE			
DD1.0			
Crestline-2			
SIZE	CODE	DOC. NUMBER	REV
A3	CS	Model No	A02

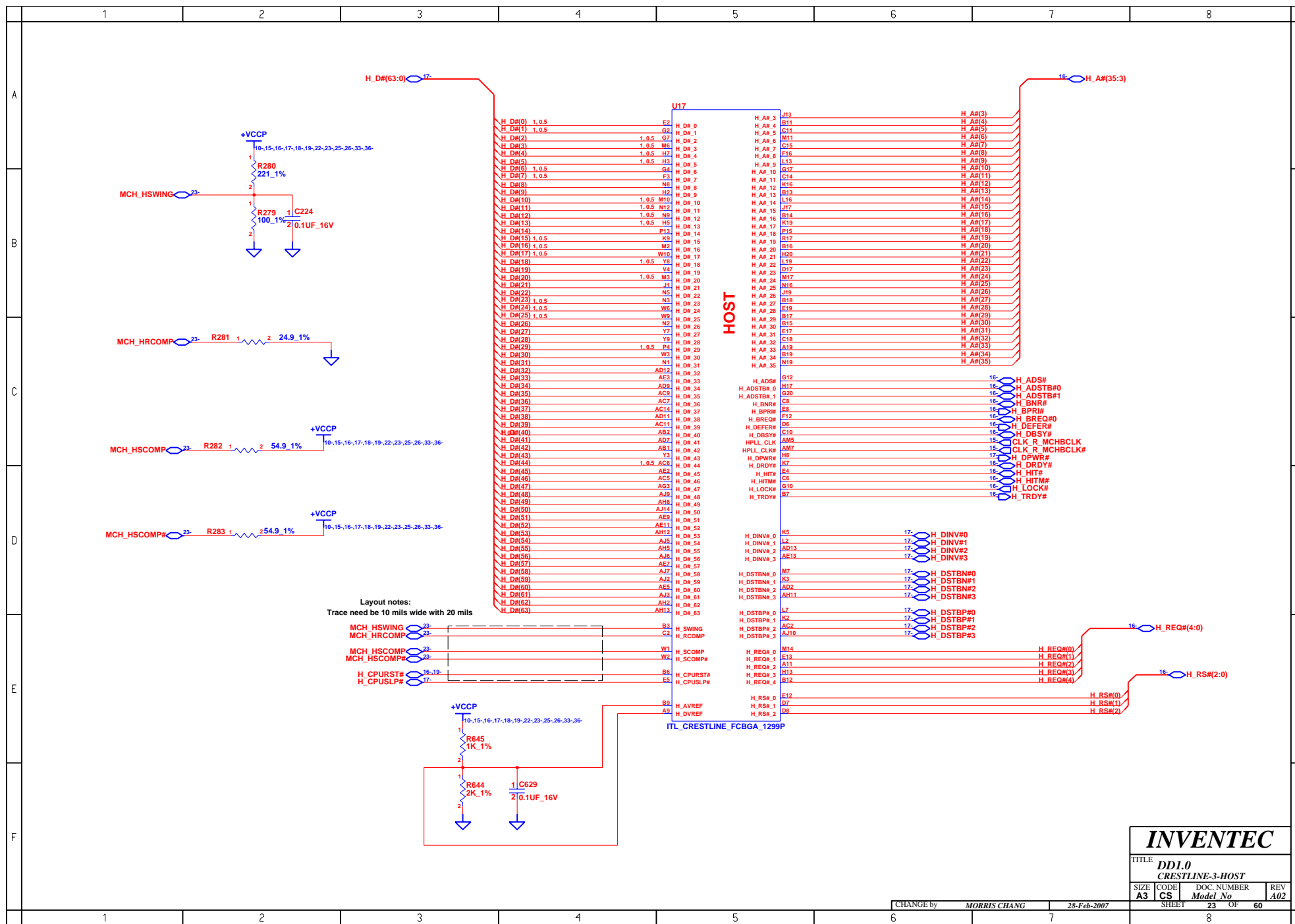

INVENTEC

TITLE
DDI.0
CRESTLINE-3-HOST

SIZE A3	CODE CS	DOC. NUMBER Model No	REV A02
------------	------------	-------------------------	------------

CHANGE by MORRIS CHANG 28-Feb-2007 SHEET 23 OF 60

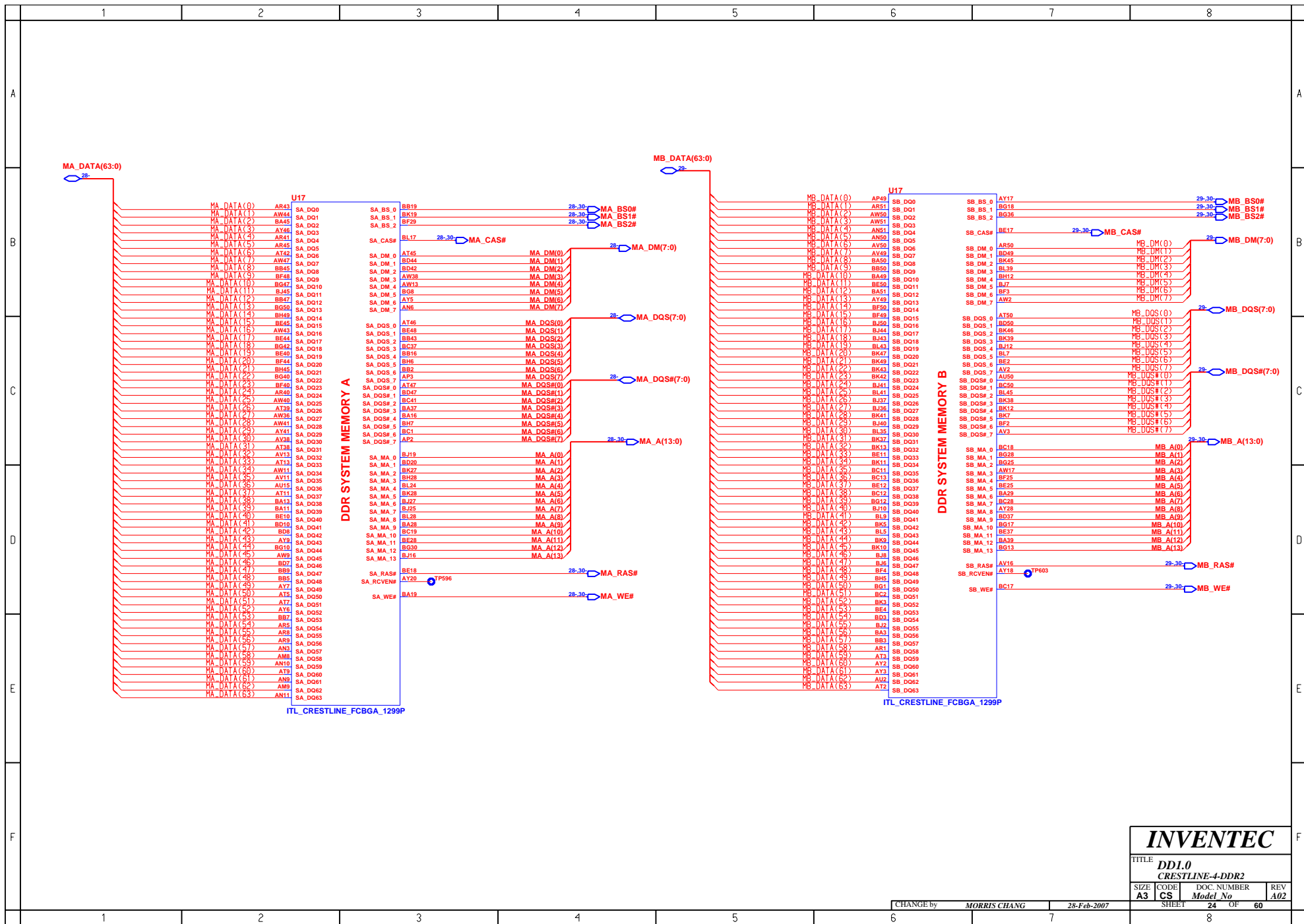

INVENTEC

TITLE
DD1.0
CRESTLINE-4-DDR2

SIZE	CODE	DOC. NUMBER	REV
A3	CS	Model No	A02

CHANGE by MORRIS CHANG 28-Feb-2007 SHEET 24 OF 60

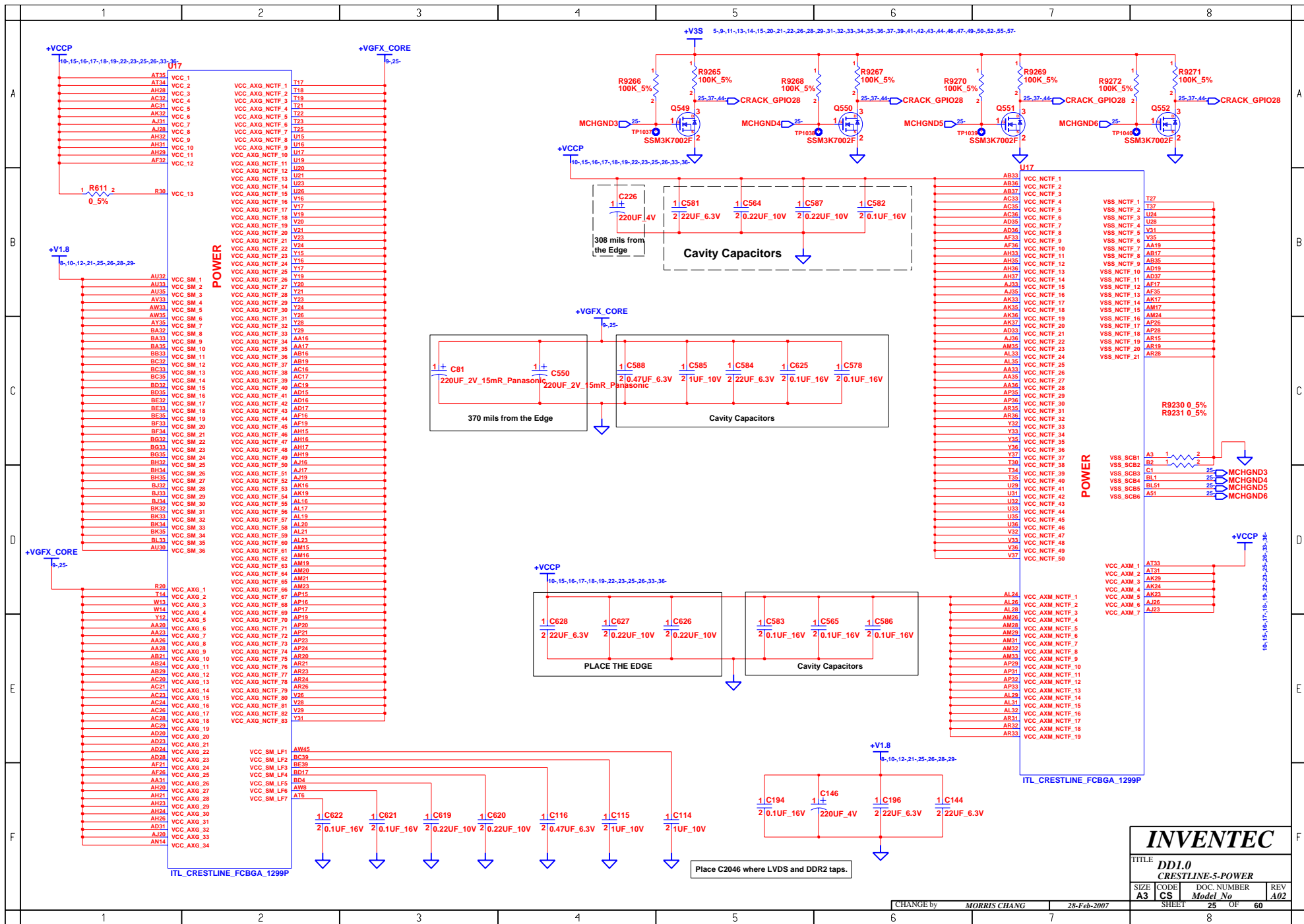

INVENTEC

TITLE			
DDI.0			
CRESTLINE-5-POWER			
SIZE	CODE	DOC. NUMBER	REV
A3	CS	Model No	A02
SHEET		25	OF 60

CHANGE by MORRIS CHANG 28-Feb-2007

Place C2046 where LVDS and DDR2 taps.

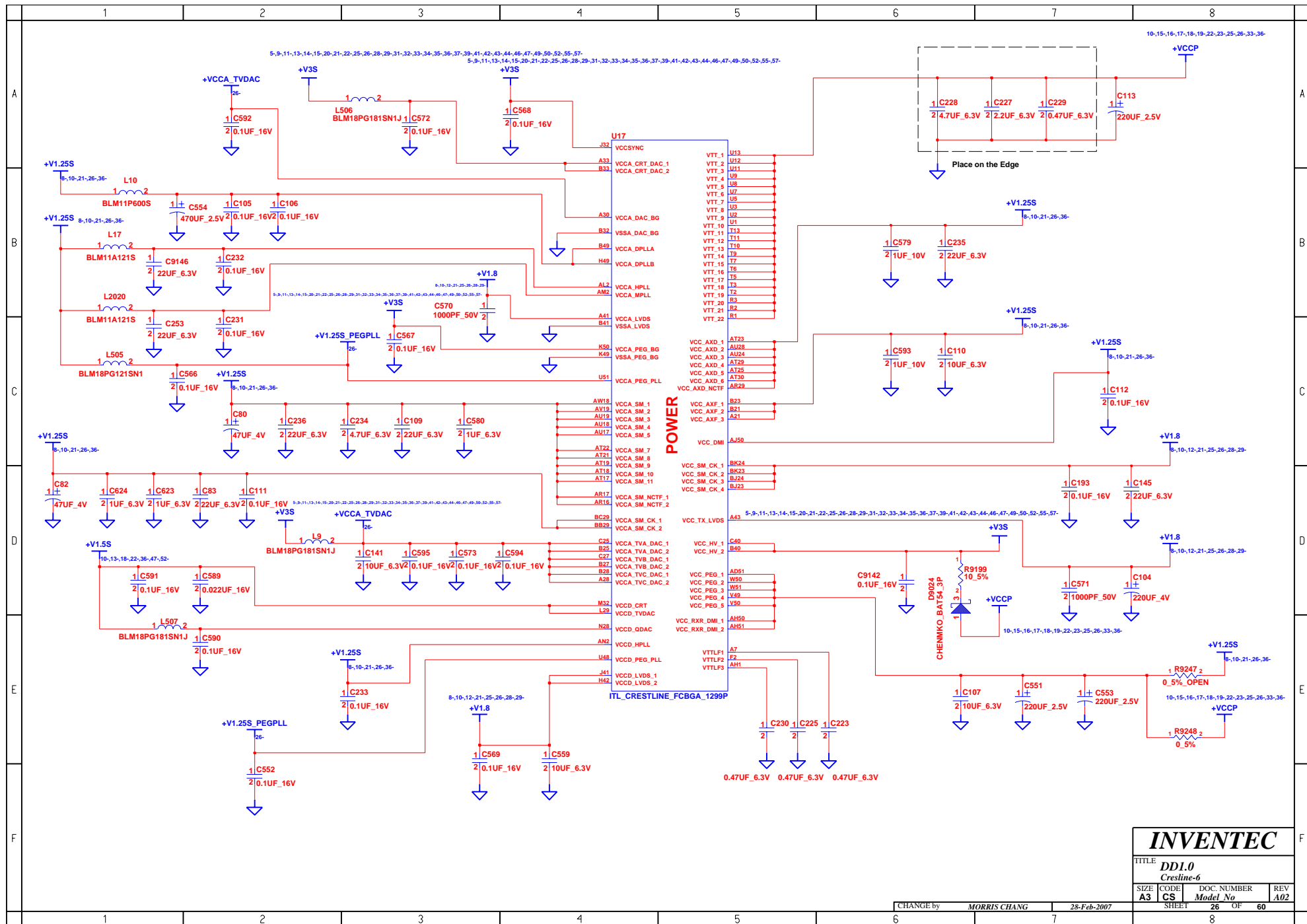

INVENTEC

TITLE
DD1.0
 Crestline-6

SIZE	CODE	DOC. NUMBER	REV
A3	CS	Model No	A02

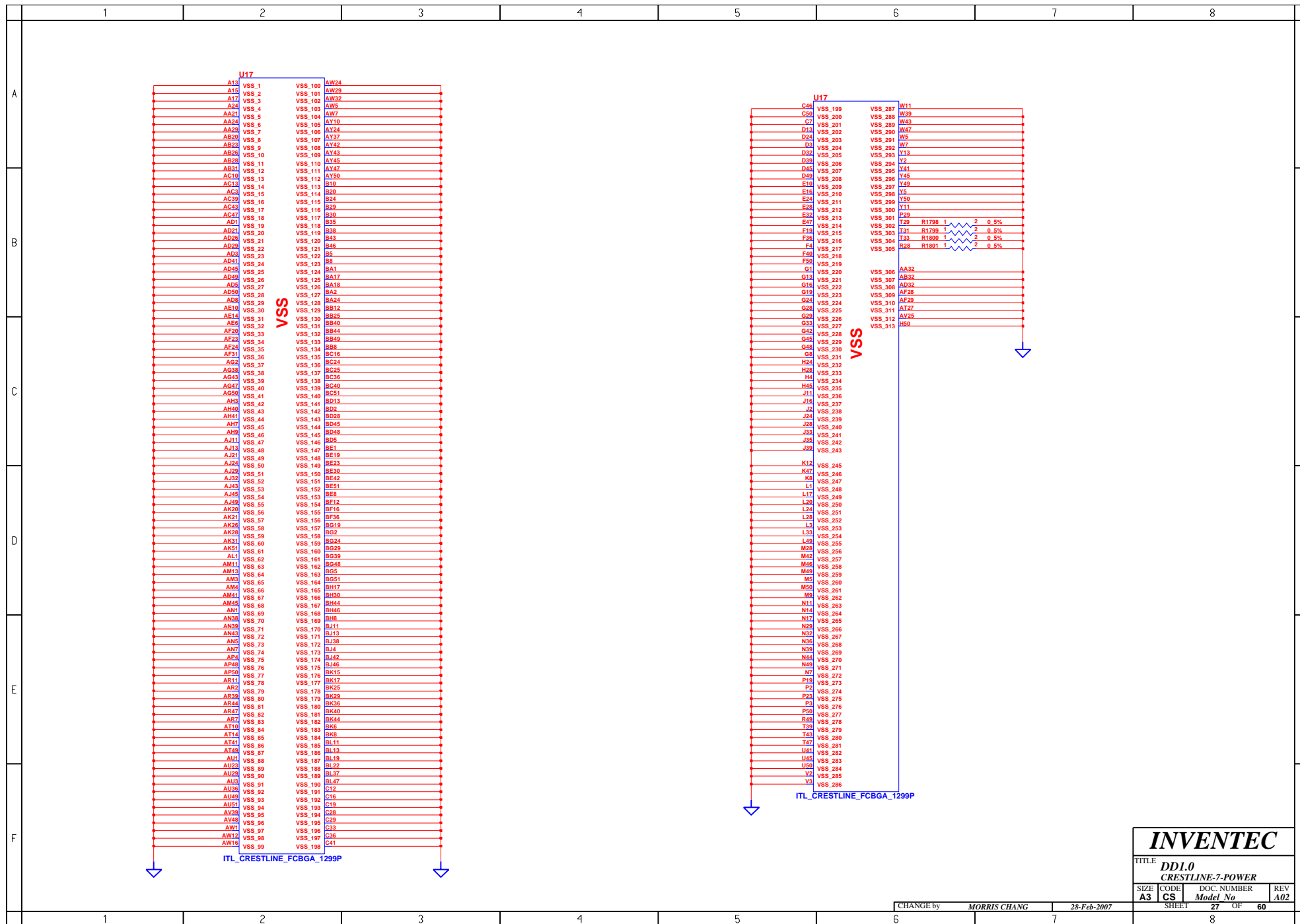

INVENTEC			
TITLE			
DDI.0 CRESTLINE-7-POWER			
SIZE	CODE	DOC. NUMBER	REV
A3	CS	Model No	A02
CHANGE by		MORRIS CHANG	28-Feb-2007
SHEET		27	OF 60

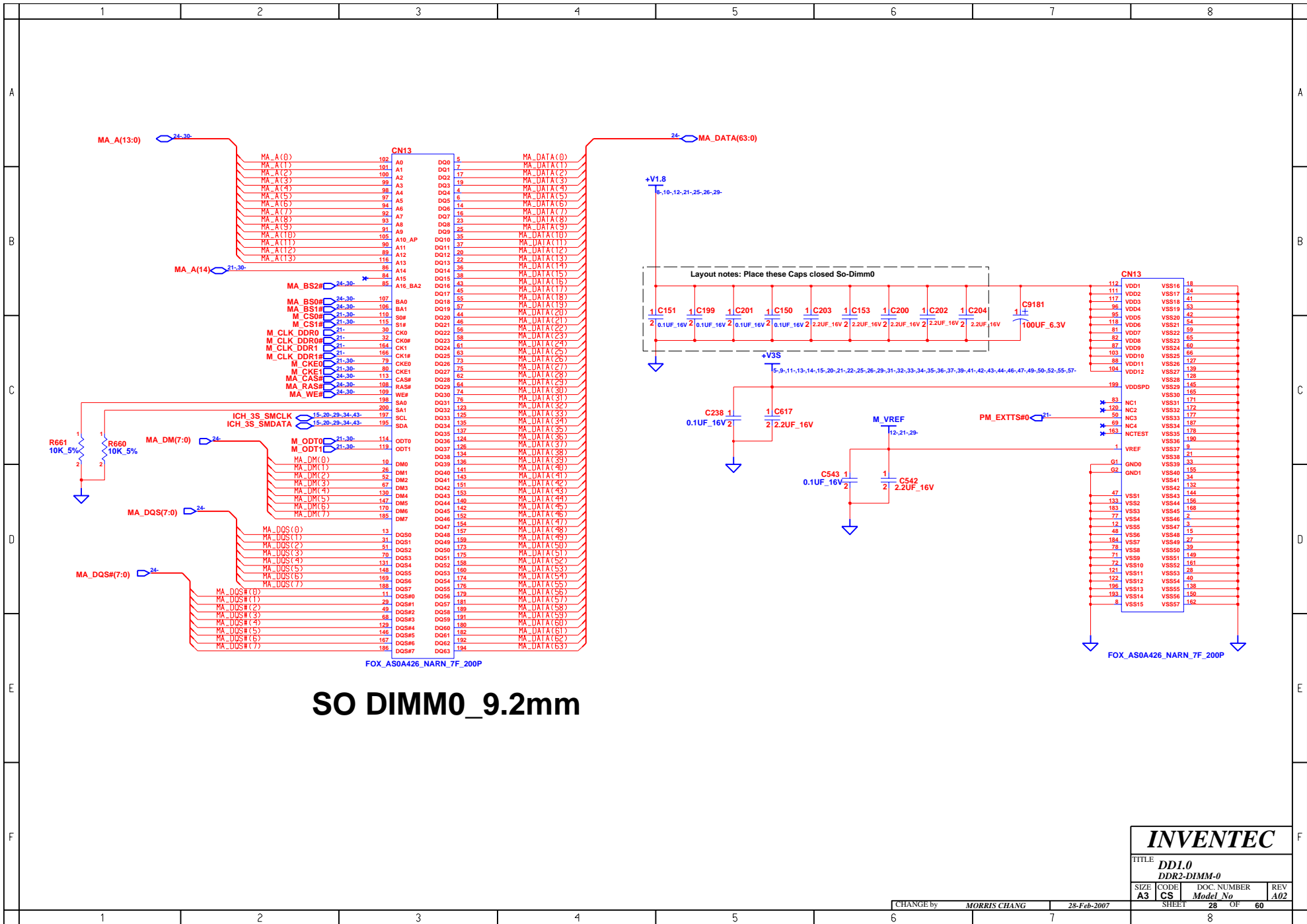

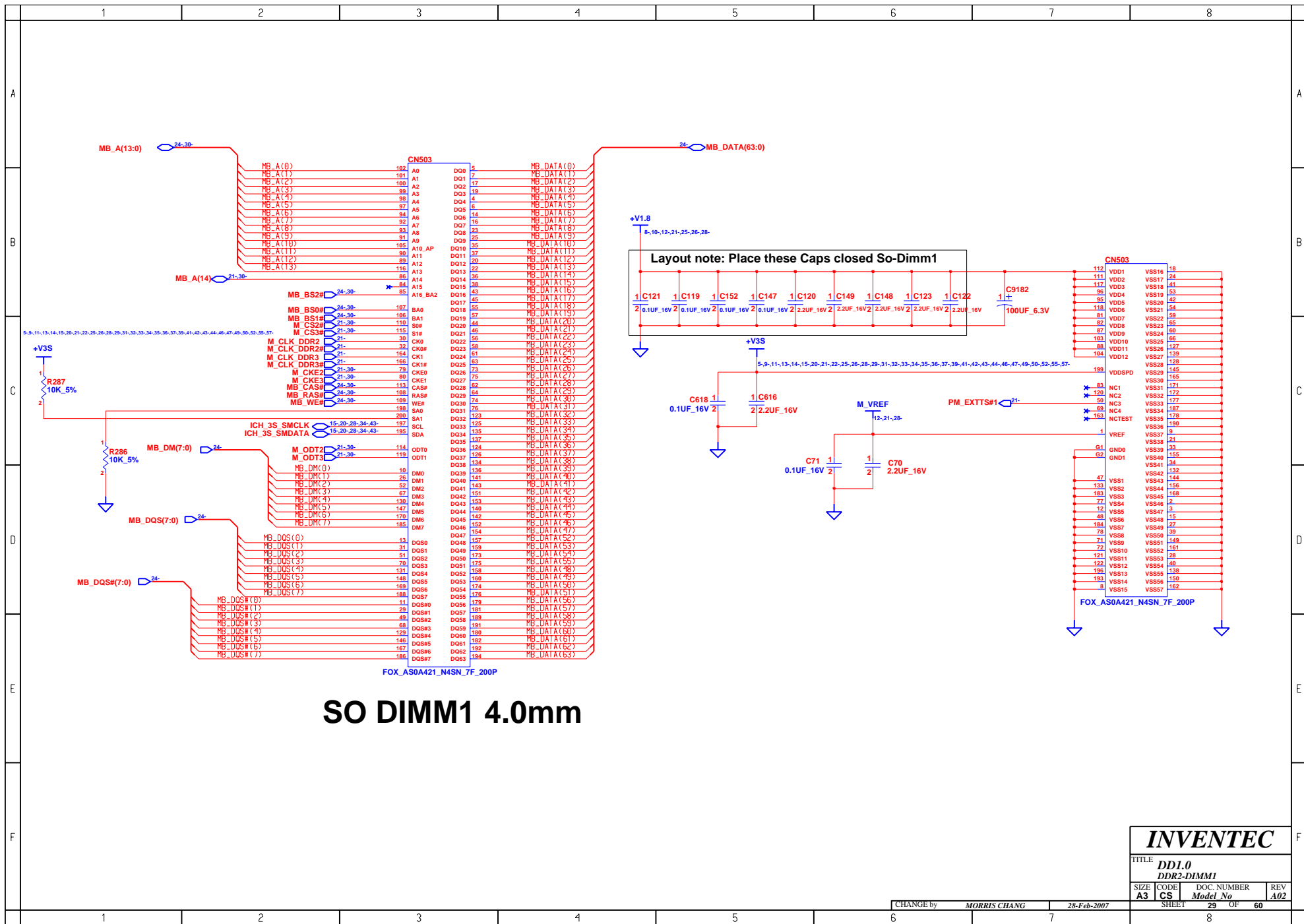

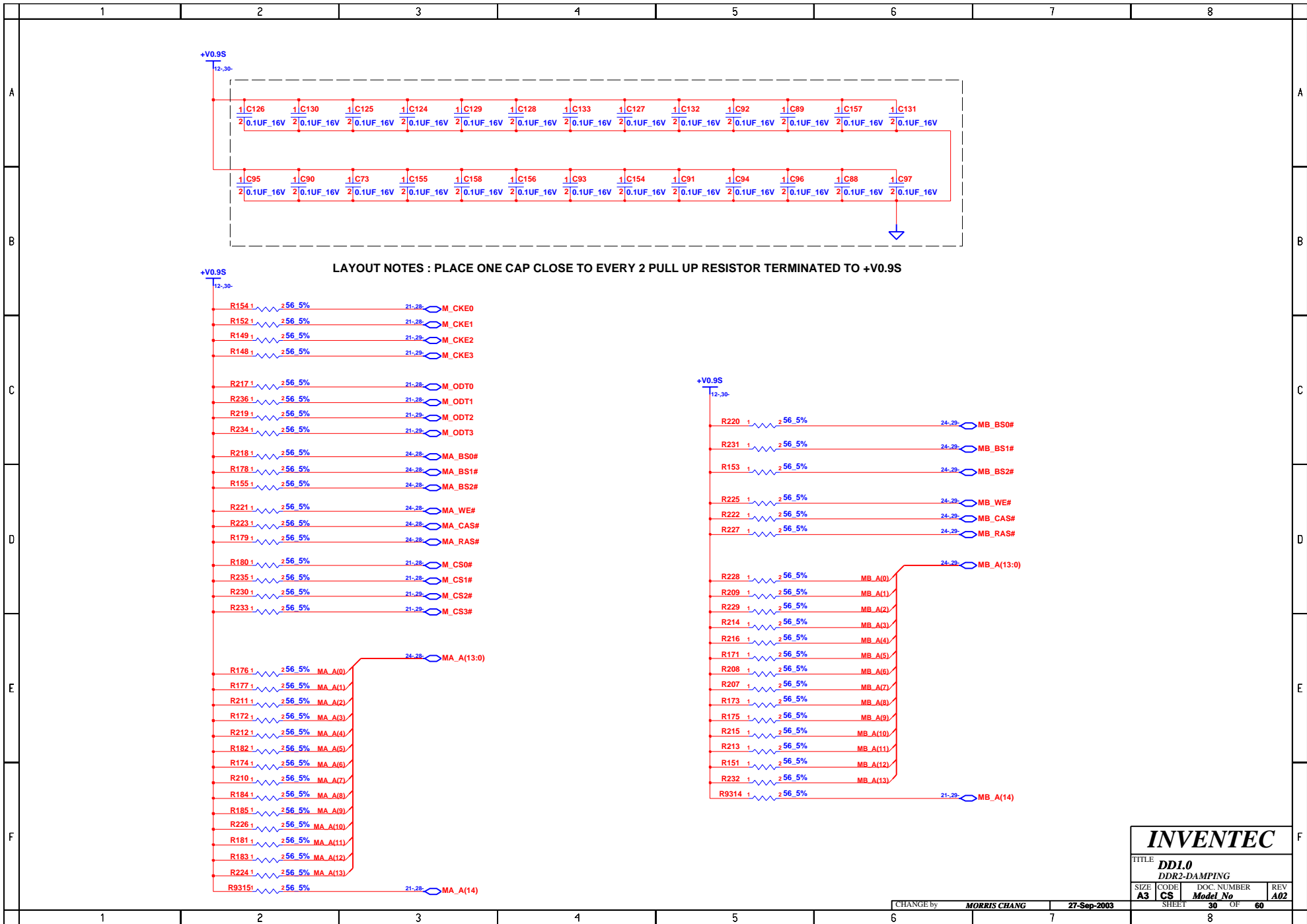

INVENTEC			
TITLE DD1.0 DDR2-DAMPING			
SIZE A3	CODE CS	DOC. NUMBER <i>Model No</i>	REV A02
CHANGE by MORRIS CHANG		27-Sep-2003	
SHEET 30		OF 60	

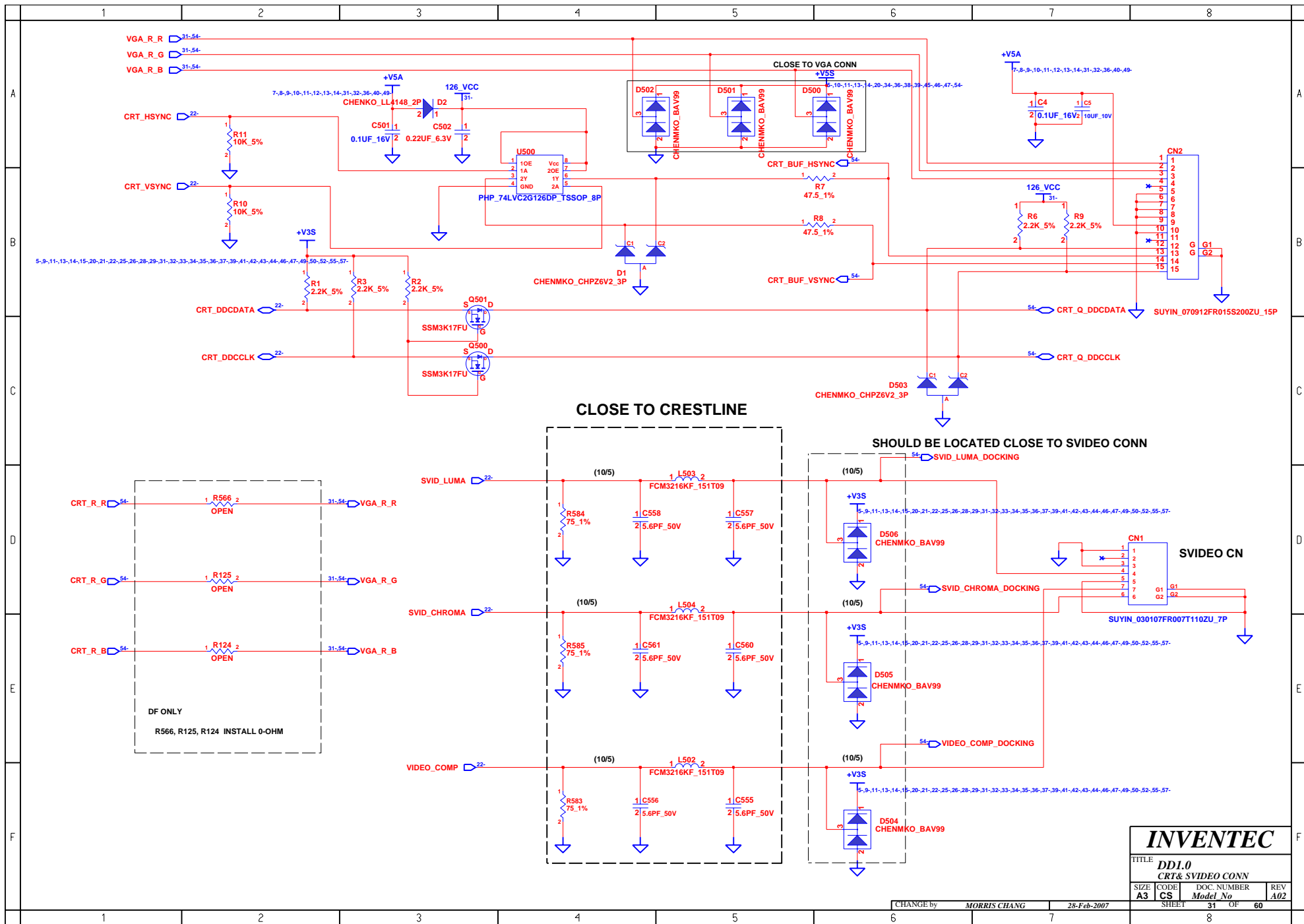

Place closed to connector

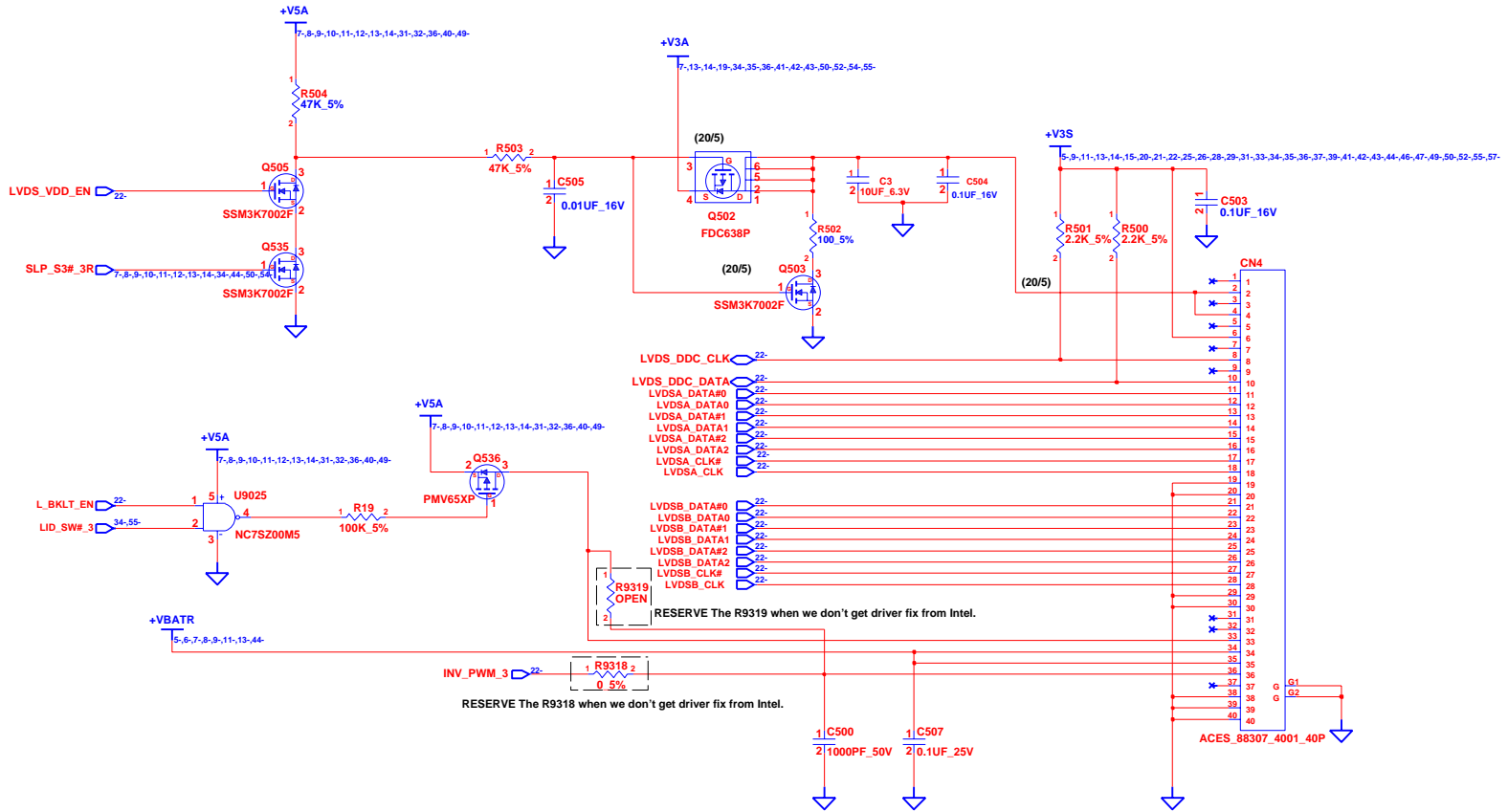

INVENTEC

TITLE			
DDI.0			
LCD CONN			
SIZE	CODE	DOC. NUMBER	REV
A3	CS	Model No	A02

CHANGE by MORRIS CHANG 28-Feb-2007

SHEET 32 OF 60

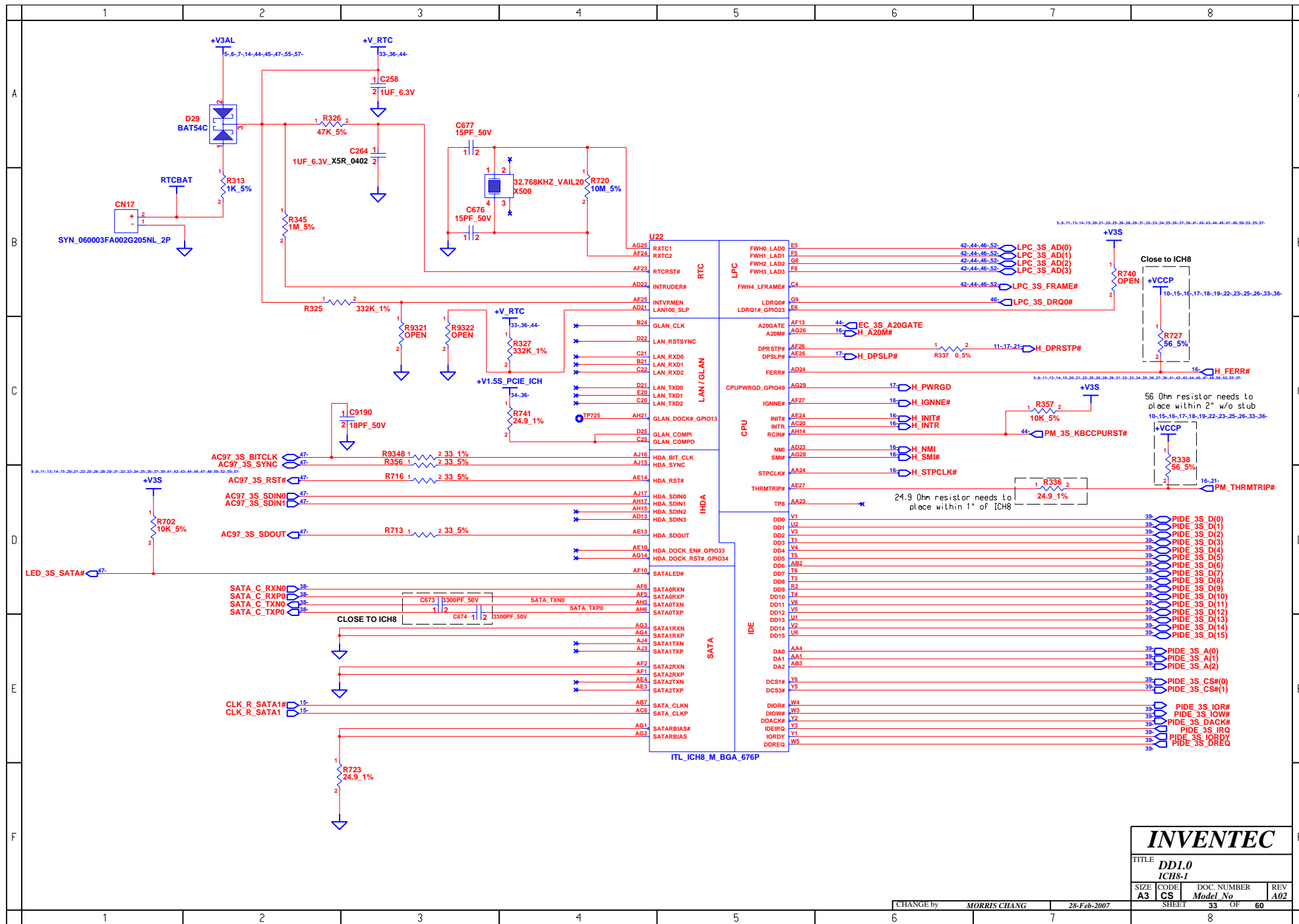

INVENTEC			
TITLE DD1.0 ICH8-1			
SIZE A3	CODE CS	DOC. NUMBER <i>Model No</i>	REV A02
CHANGE by <i>MORRIS CHANG</i>		28-Feb-2007	
SHEET		33 OF 60	

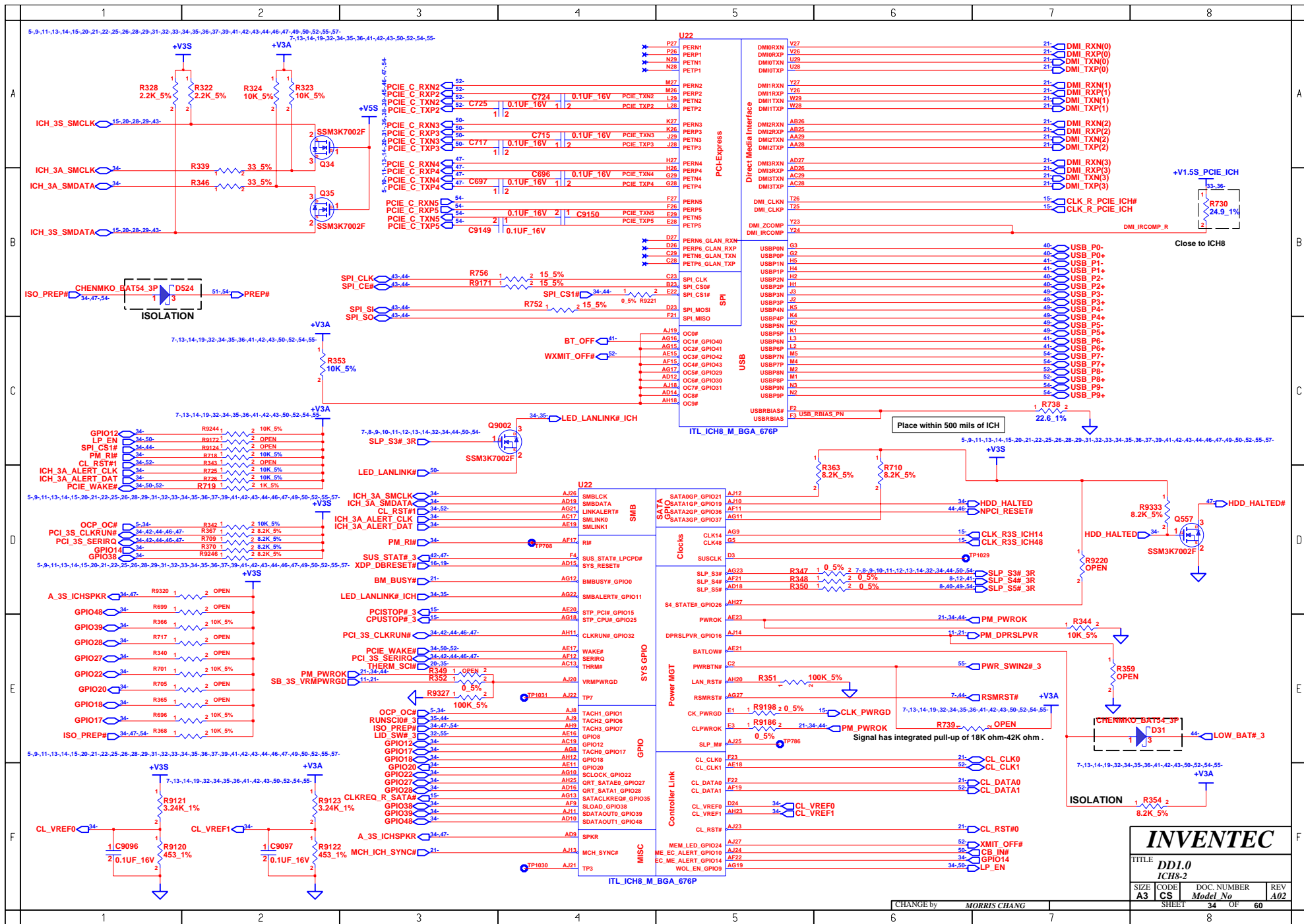

INVENTEC

TITLE **DDI.0 ICH8-2**

SIZE A3	CODE CS	DOC. NUMBER Model No	REV A02
SHEET 34		OF 60	

CHANGE by **MORRIS CHANG**

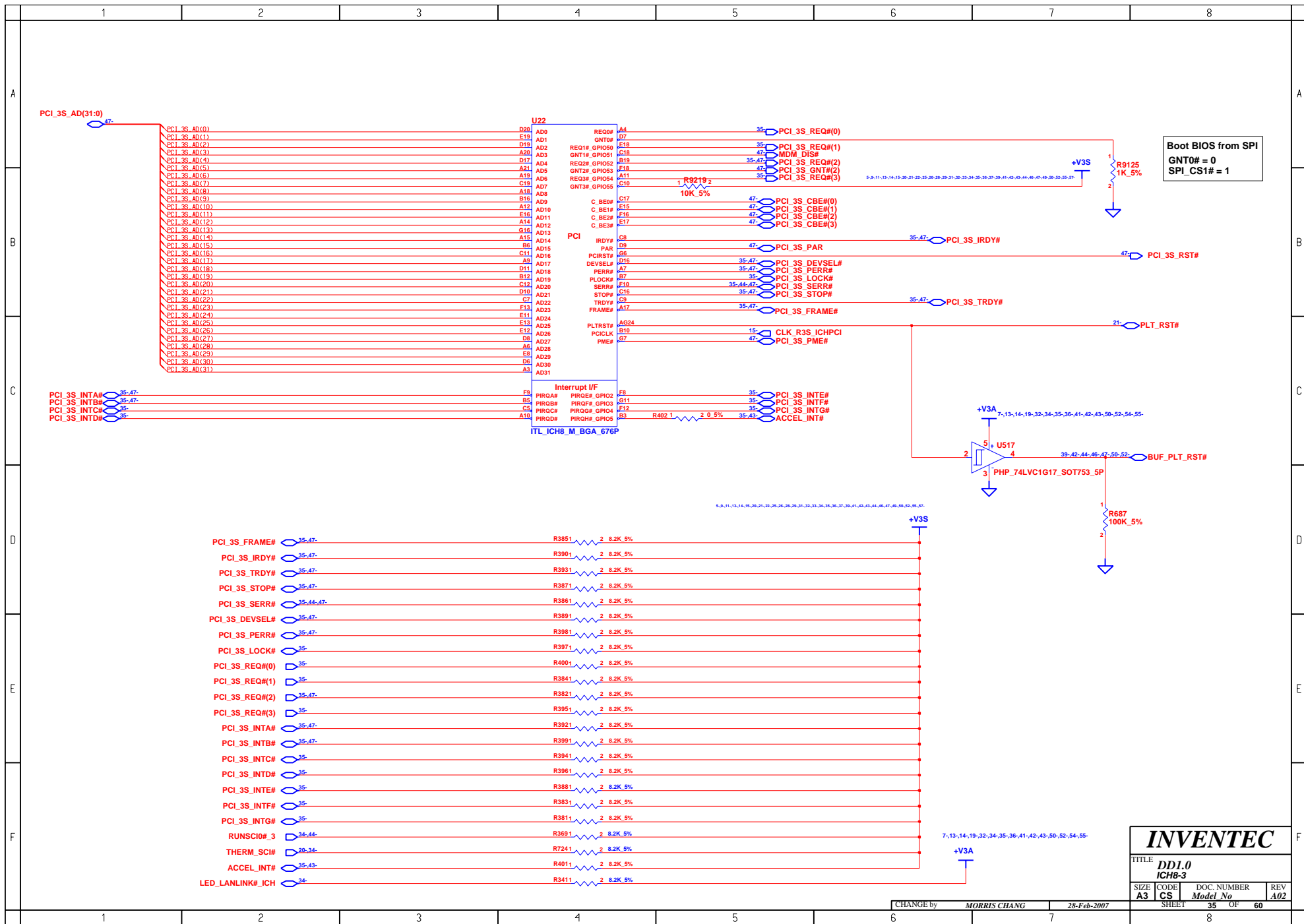

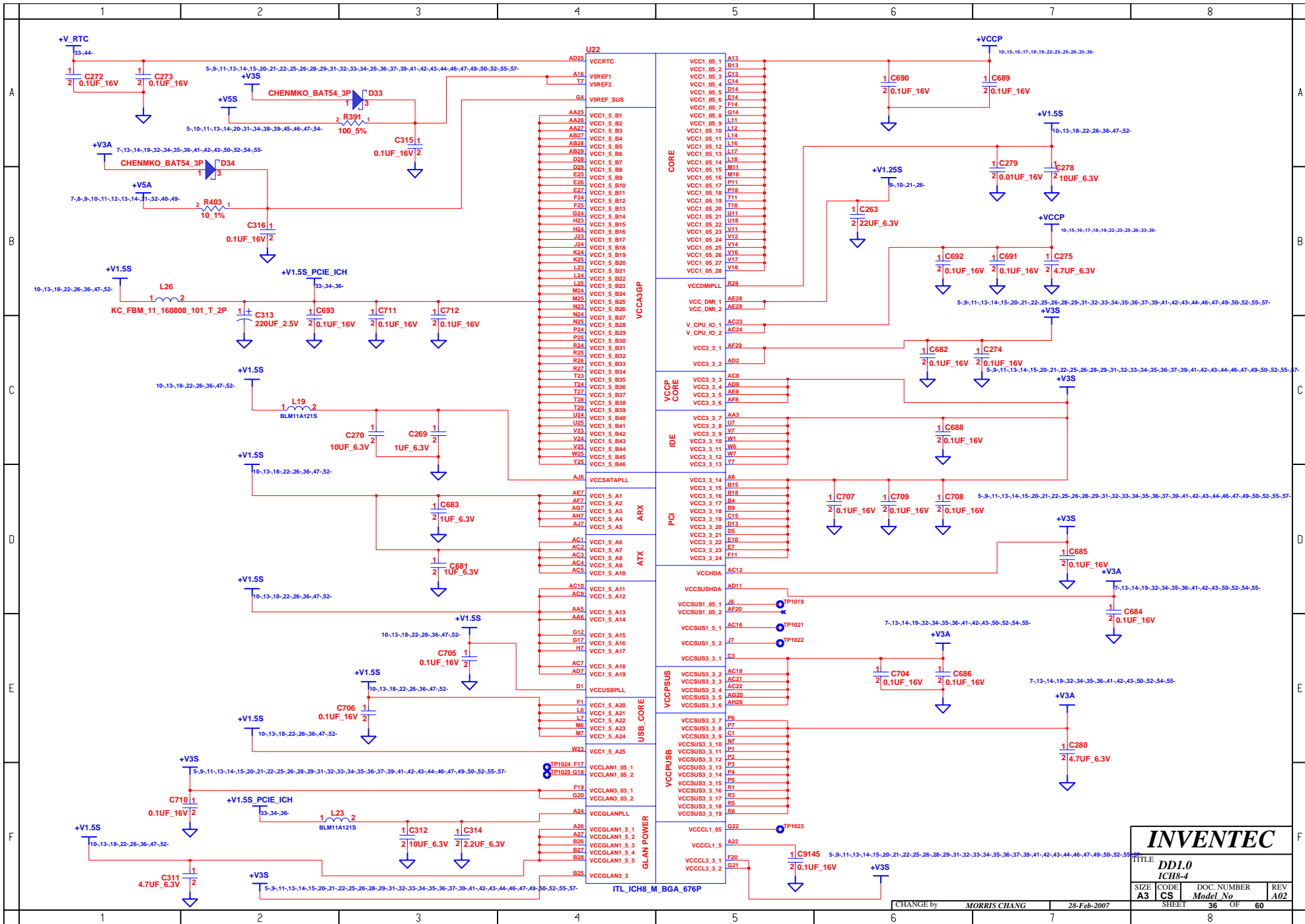

INVENTEC

DD1.0
ICH8-4

SIZE	CODE	DOC. NUMBER	REV
A3	CS	Model No	A02

SHEET 36 OF 60

CHANGE by MORRIS CHANG 28-Feb-2007

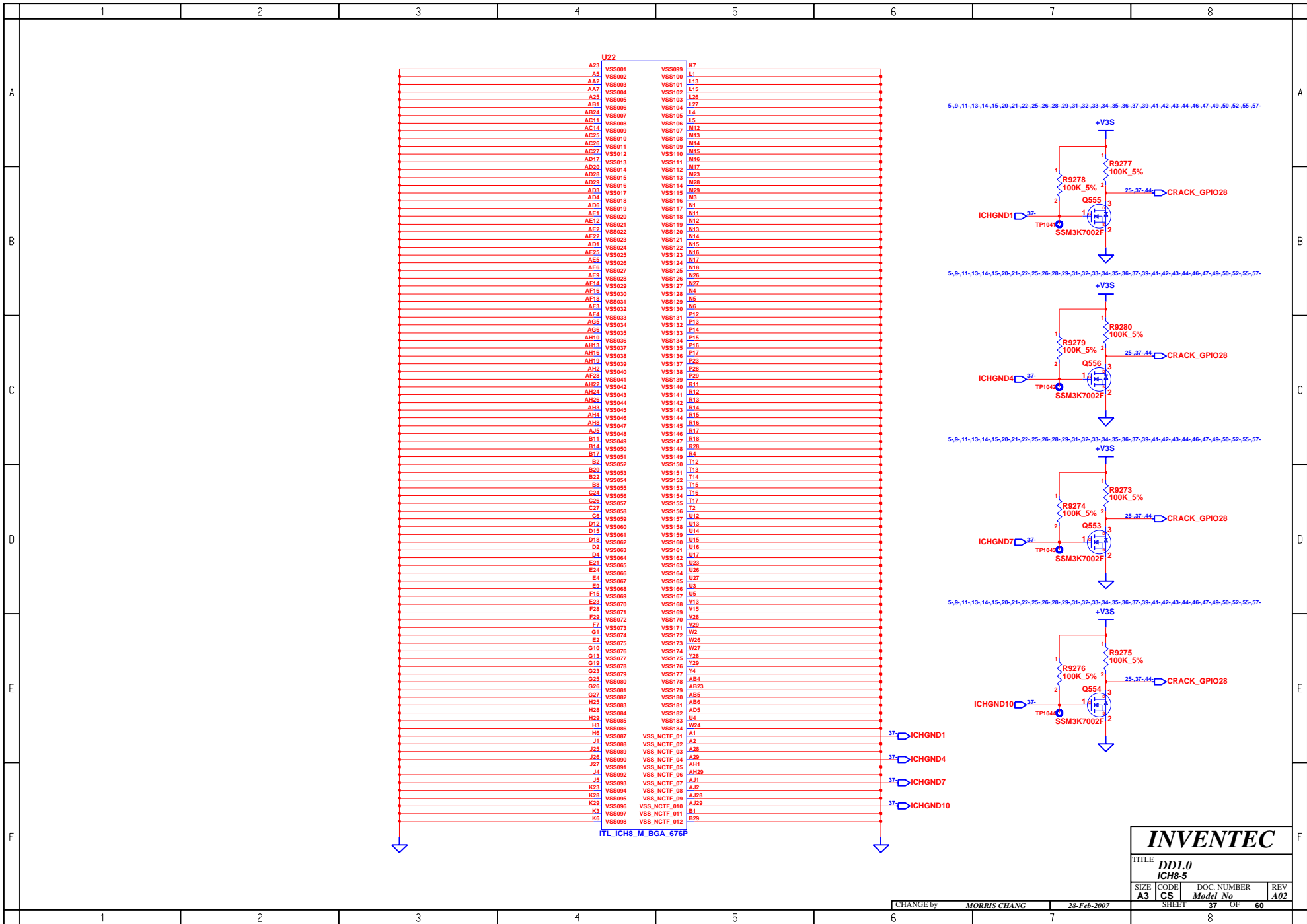

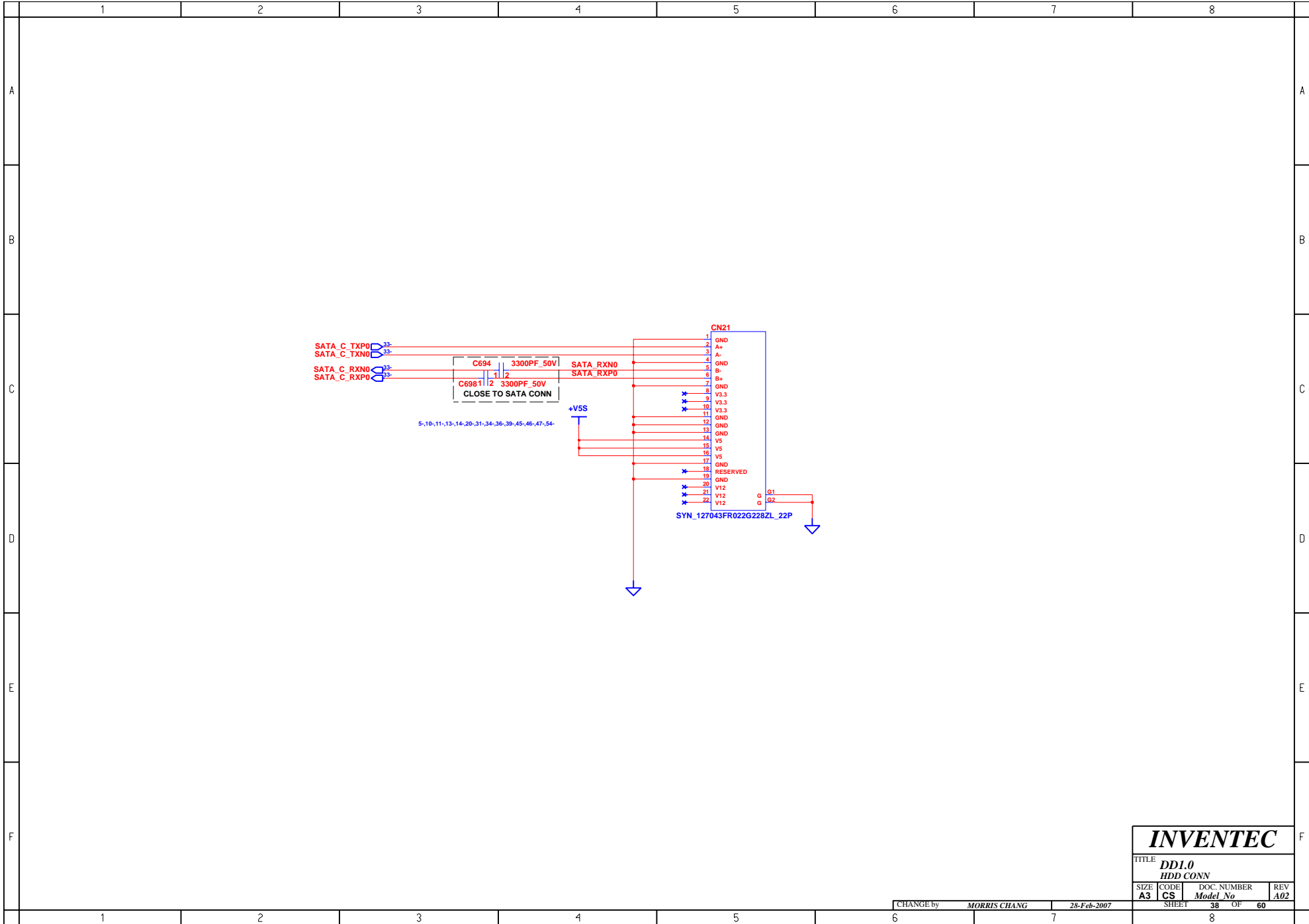

INVENTEC			
TITLE DD1.0 HDD CONN			
SIZE A3	CODE CS	DOC. NUMBER <i>Model No</i>	REV A02
CHANGE by <i>MORRIS CHANG</i>		28-Feb-2007	SHEET 38 OF 60

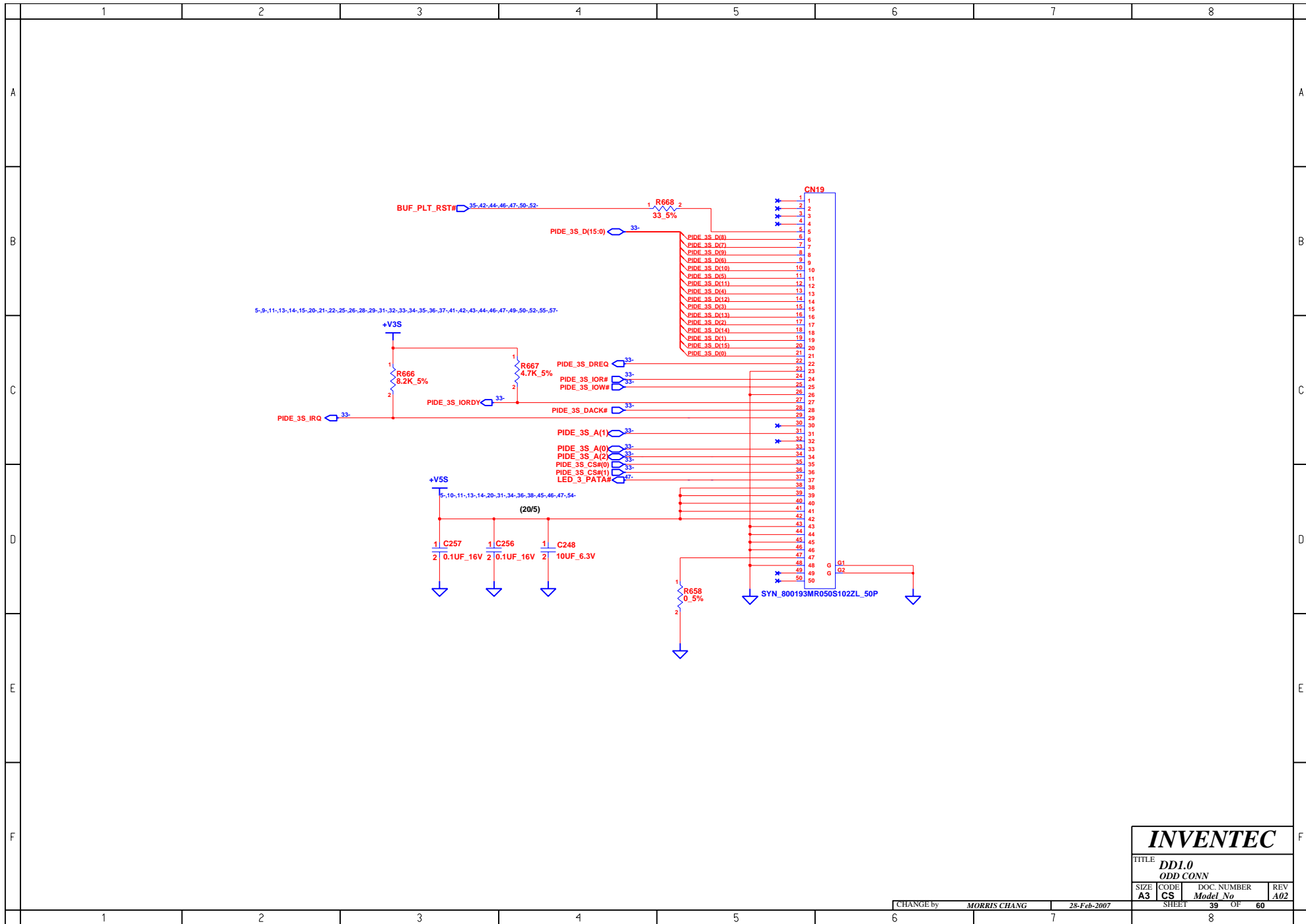

INVENTEC

TITLE			
DD1.0			
ODD CONN			
SIZE	CODE	DOC. NUMBER	REV
A3	CS	Model No	A02

CHANGE by MORRIS CHANG 28-Feb-2007

SHEET 39 OF 60

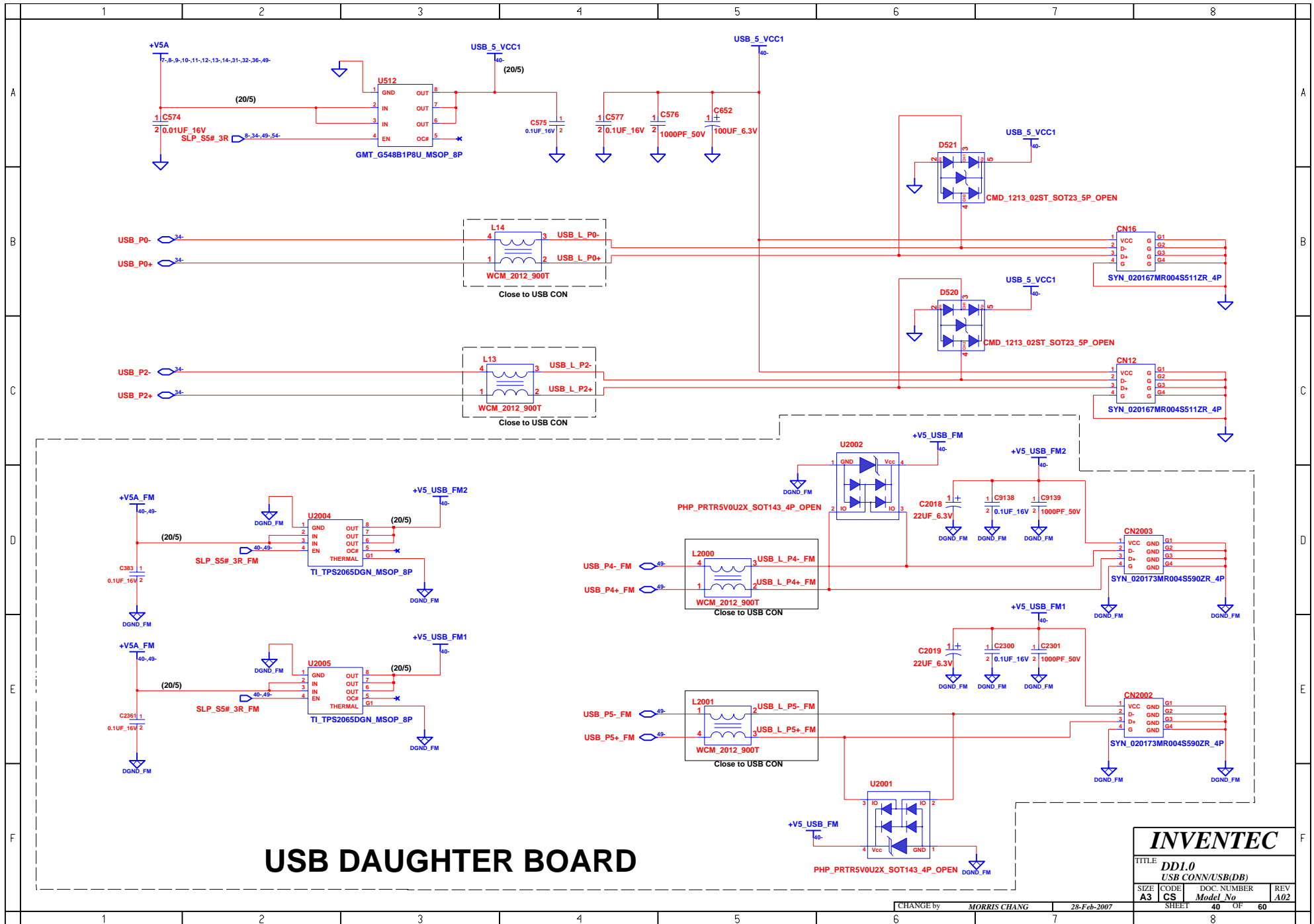

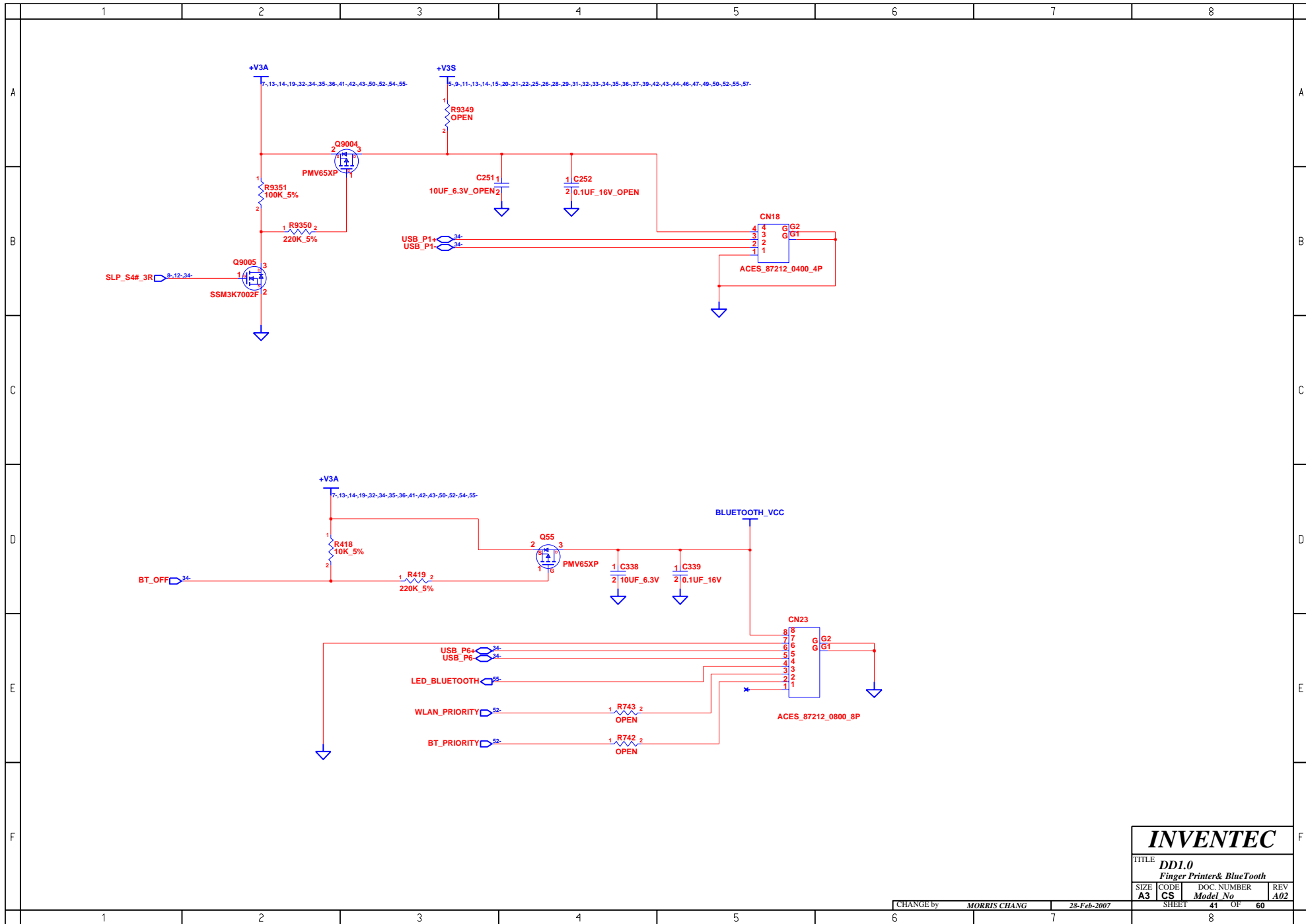

INVENTEC

TITLE			
DD1.0			
Finger Printer & BlueTooth			
SIZE	CODE	DOC. NUMBER	REV
A3	CS	Model No	A02

CHANGE by MORRIS CHANG 28-Feb-2007

SHEET 41 OF 60

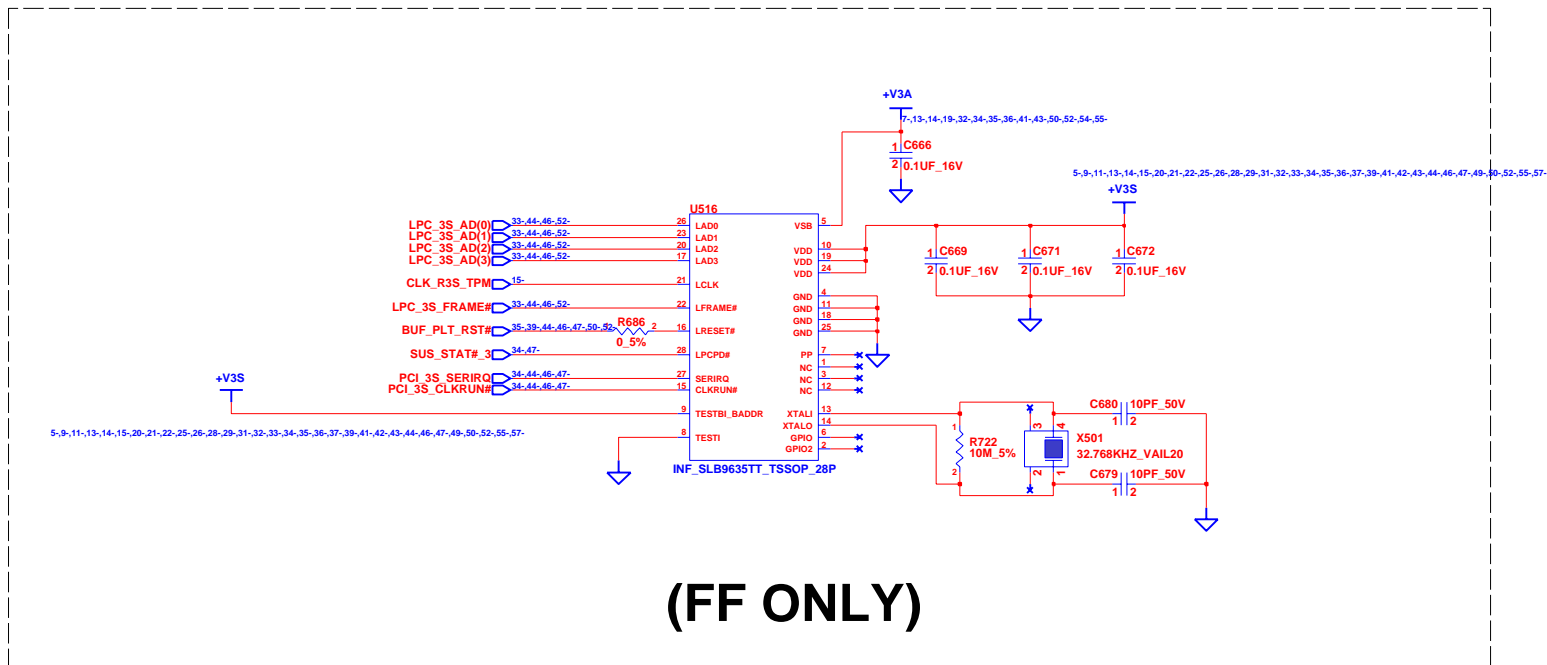

(FF ONLY)

INVENTEC

TITLE			
DD1.0			
TPM V1.2			
SIZE	CODE	DOC. NUMBER	REV
A3	CS	Model No	A02
CHANGE by		SHEET	
MORRIS CHANG		42 OF 60	

28-Feb-2007

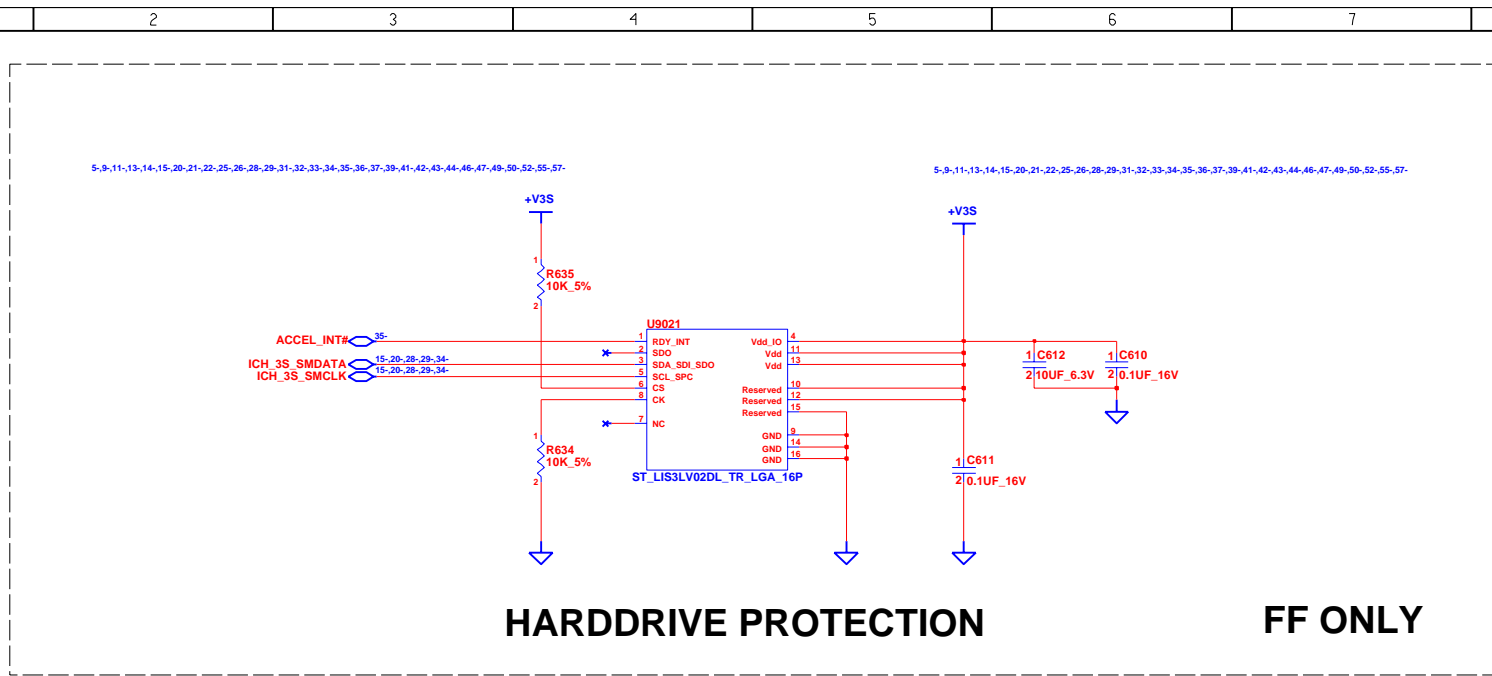

FF ONLY

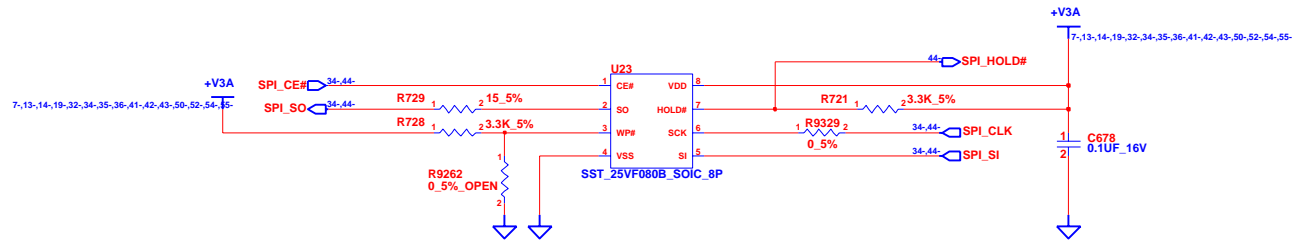

INVENTEC			
TITLE DD1.0 SPI/HDD PROTECTION			
SIZE A3	CODE CS	DOC. NUMBER <i>Model No</i>	REV A02
CHANGE by <i>MORRIS CHANG</i>		28-Feb-2007	
SHEET 43		OF 60	

1	2	3	4	5	6	7	8
A	[Schematic Diagrams]						A
B	[Schematic Diagrams]						B
C	[Schematic Diagrams]						C
D	[Schematic Diagrams]						D
E	[Schematic Diagrams]						E
F	[Schematic Diagrams]						F
1	2	3	4	5	6	7	8

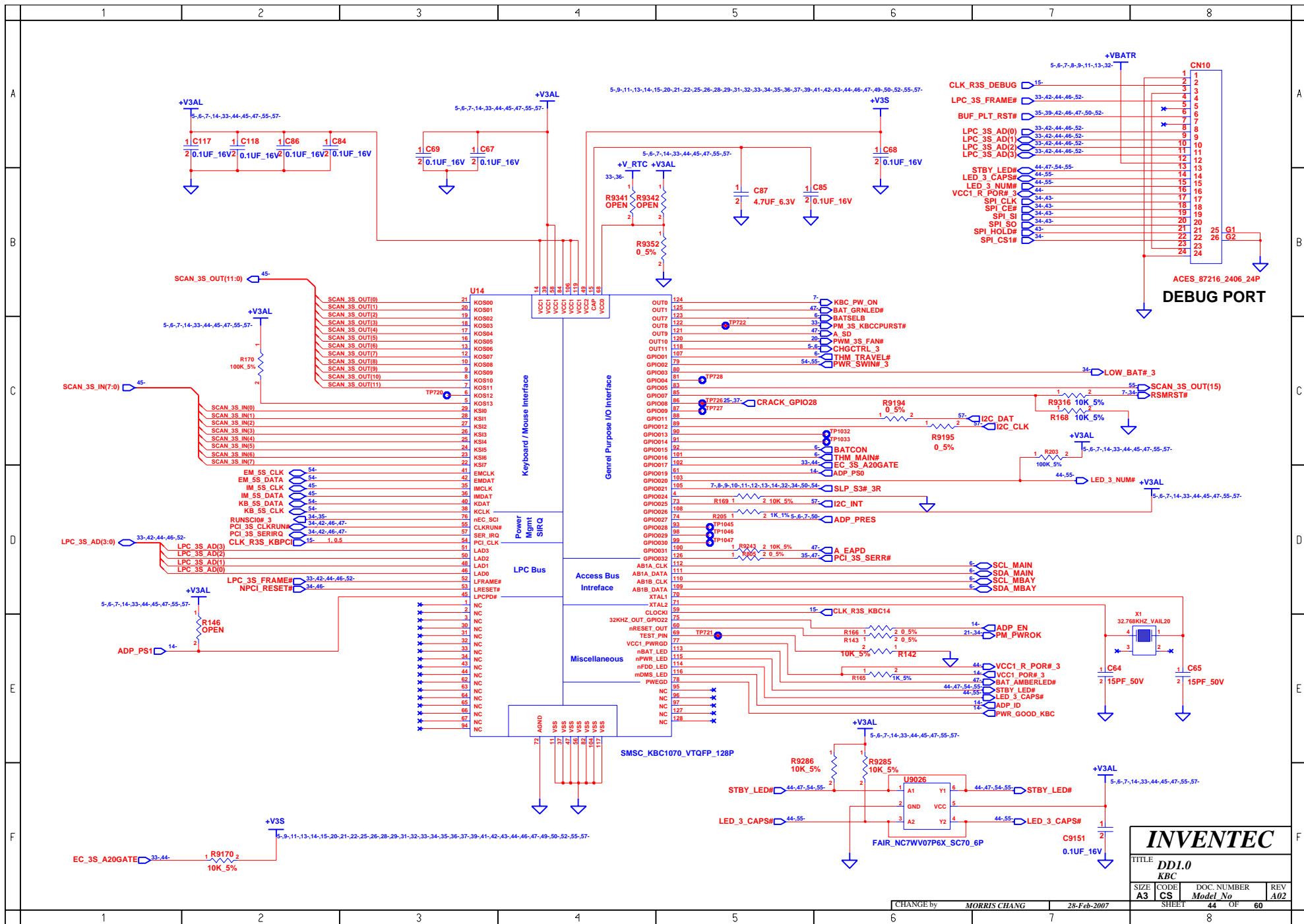

INVENTEC

TITLE **DD1.0**
KBC

SIZE A3	CODE CS	DOC. NUMBER	REV A02
		Model No	

SHEET **44** OF **60**

CHANGE by **MORRIS CHANG** 28-Feb-2007

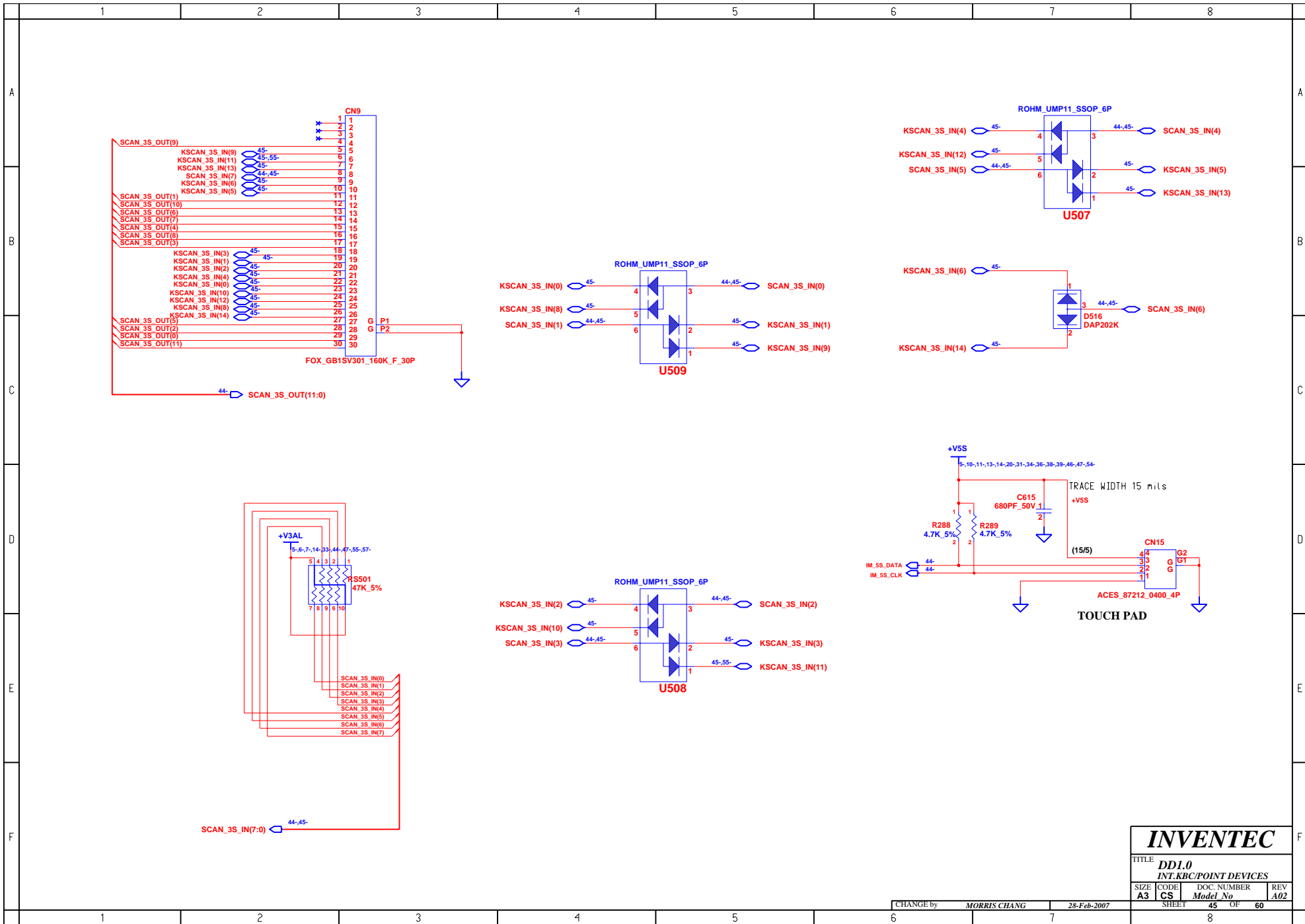

INVENTEC

TITLE
DD1.0
 INT.KBC/POINT DEVICES

SIZE A3	CODE CS	DOC. NUMBER Model No	REV A02
-------------------	-------------------	-------------------------	-------------------

CHANGE by **MORRIS CHANG** 28-Feb-2007

SHEET 45 OF 60

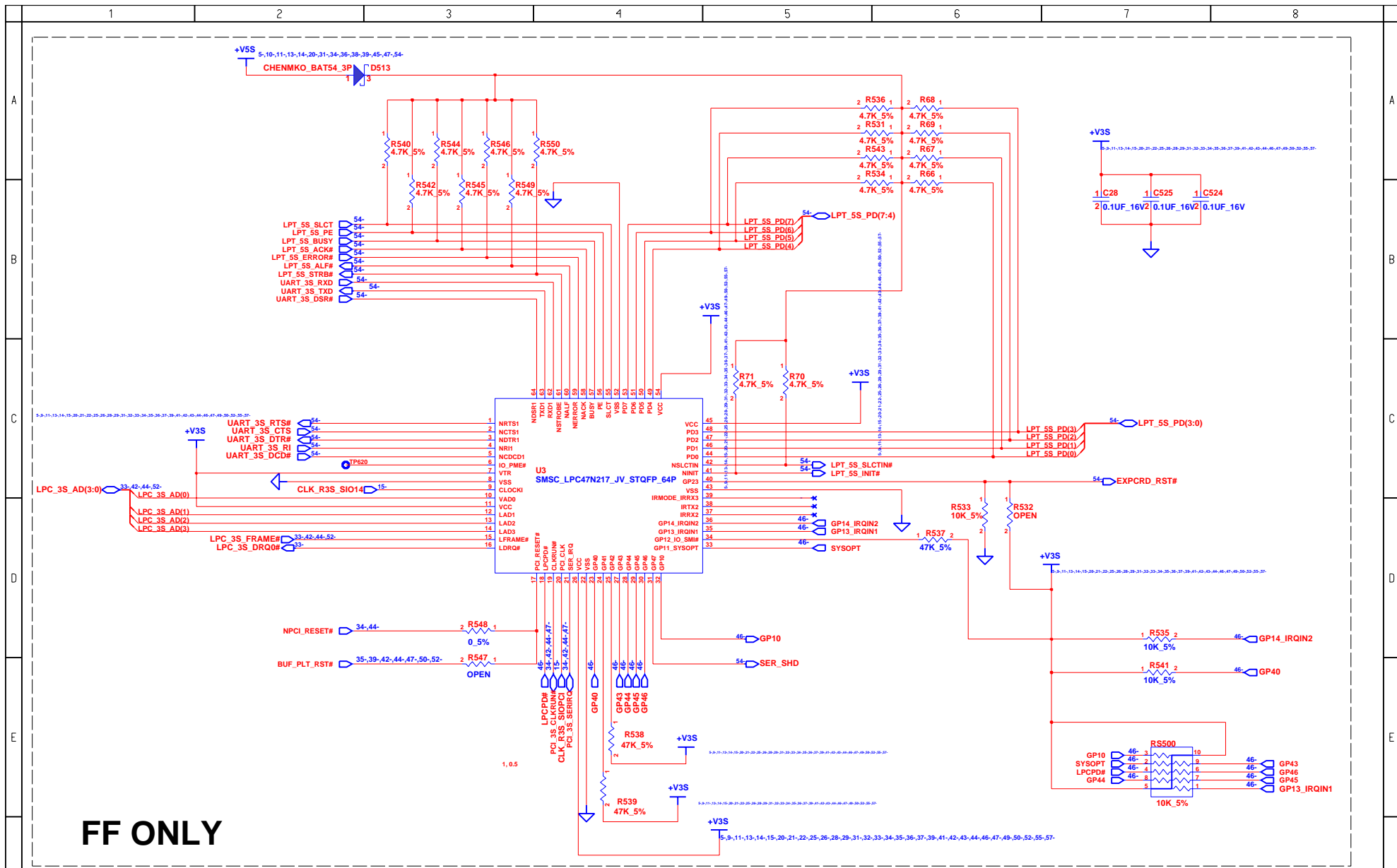

INVENTEC			
TITLE DD1.0 SUPER I/O			
SIZE A3	CODE CS	DOC. NUMBER Model No	REV A02
CHANGE by MORRIS CHANG		28-Feb-2007	
SHEET 46		OF 60	

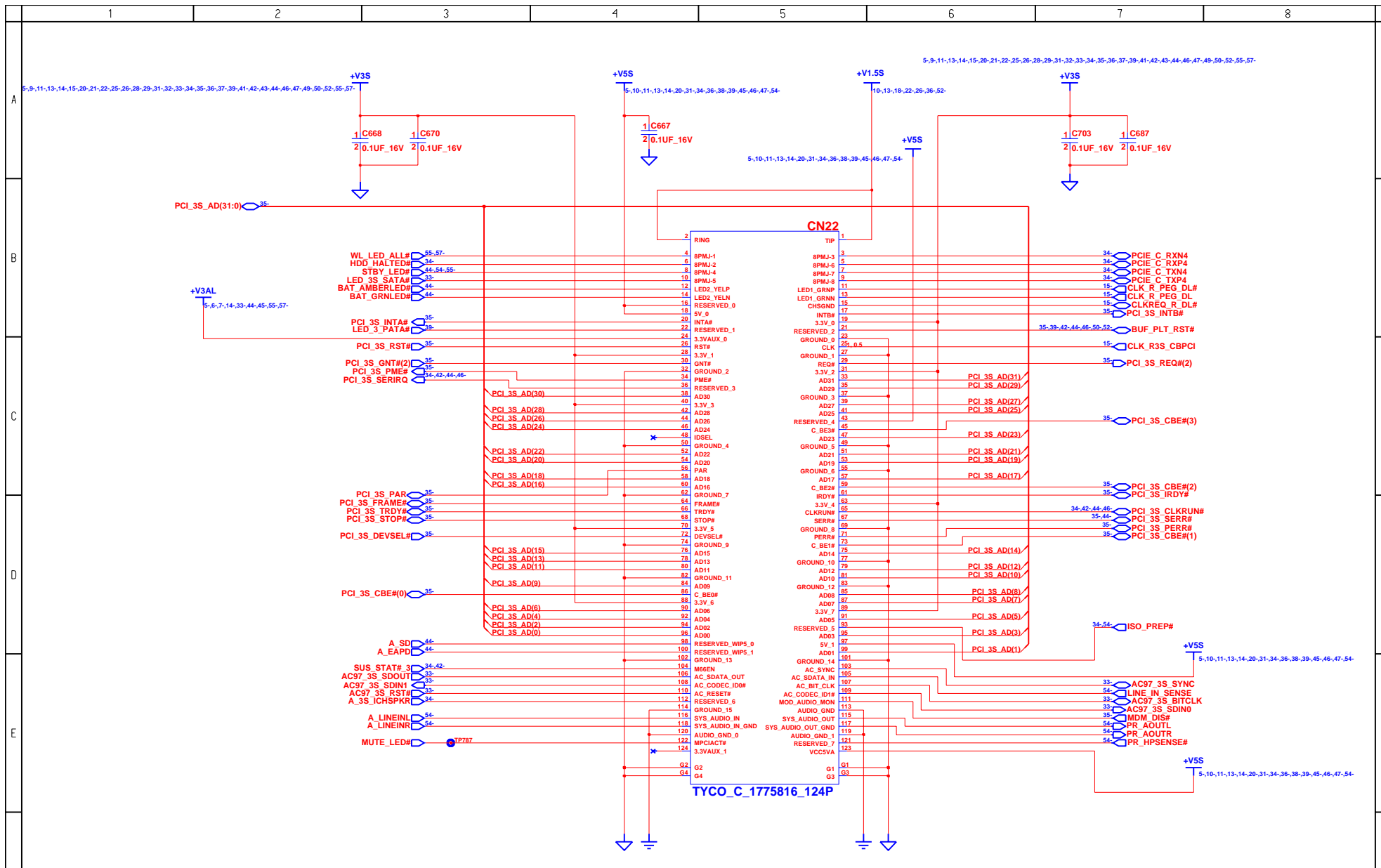

BOARD TO BOARD CONN FOR CARDBUS, 1394, MDC, AUDIO, LED.

INVENTEC			
TITLE DDI.0 DAUGHTER BOARD CONN			
SIZE A3	CODE CS	DOC. NUMBER Model No	REV A02
CHANGE by MORRIS CHANG		28-Feb-2007	SHEET 47 OF 60

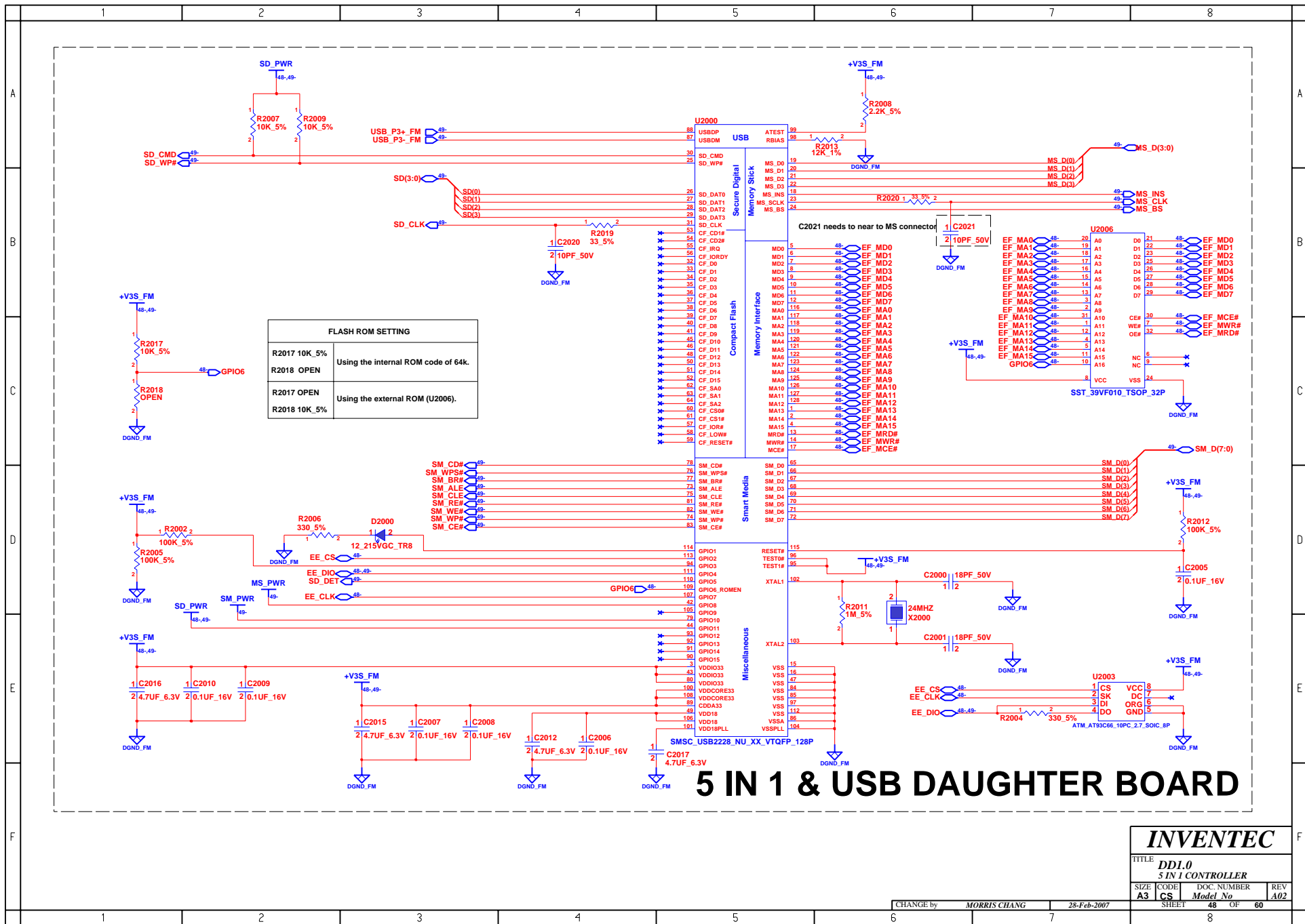

5 IN 1 & USB DAUGHTER BOARD

INVENTEC

TITLE **DDI.0**
5 IN 1 CONTROLLER

SIZE	CODE	DOC. NUMBER	REV
A3	CS	Model No	A02

CHANGE by MORRIS CHANG 28-Feb-2007 SHEET 8 OF 60

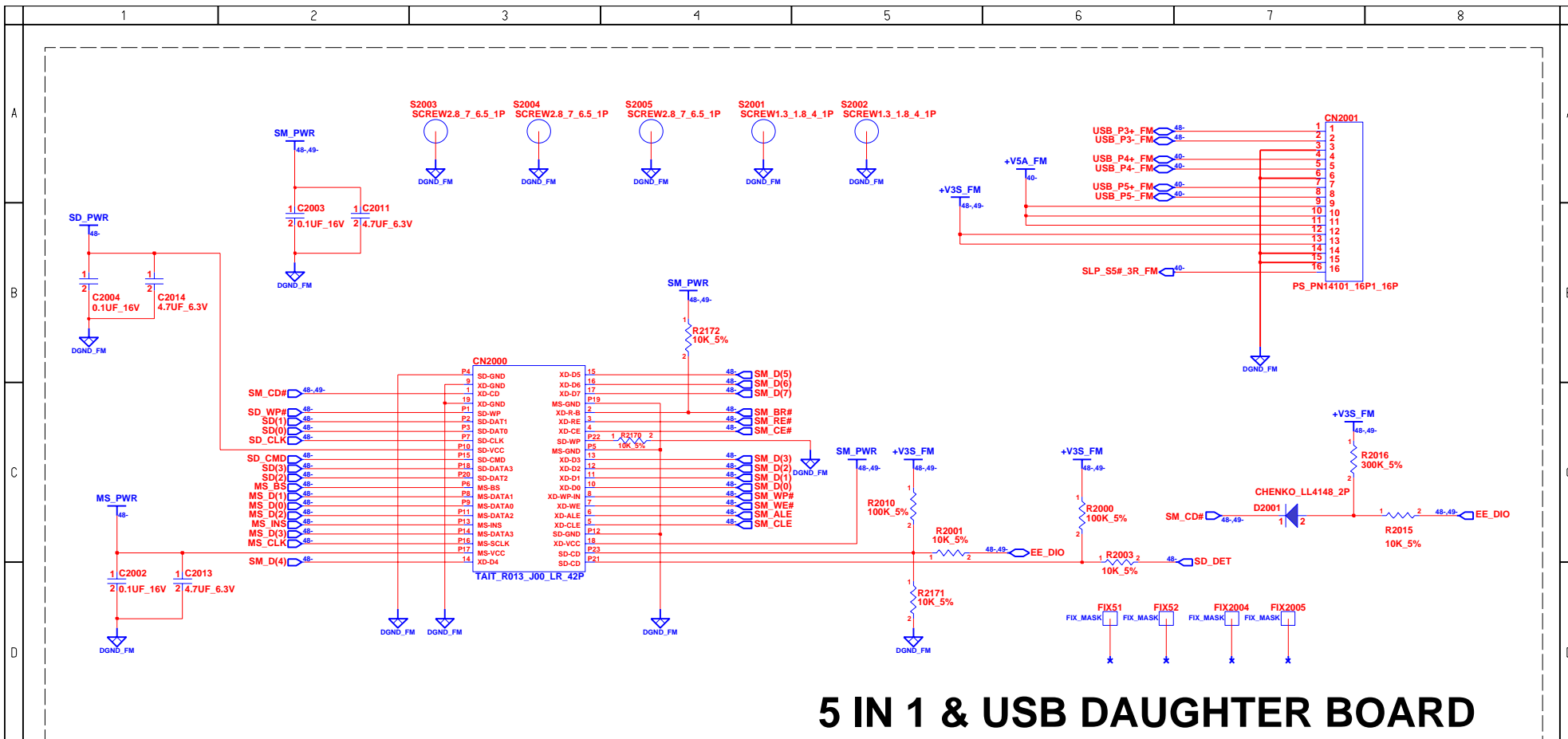

5 IN 1 & USB DAUGHTER BOARD

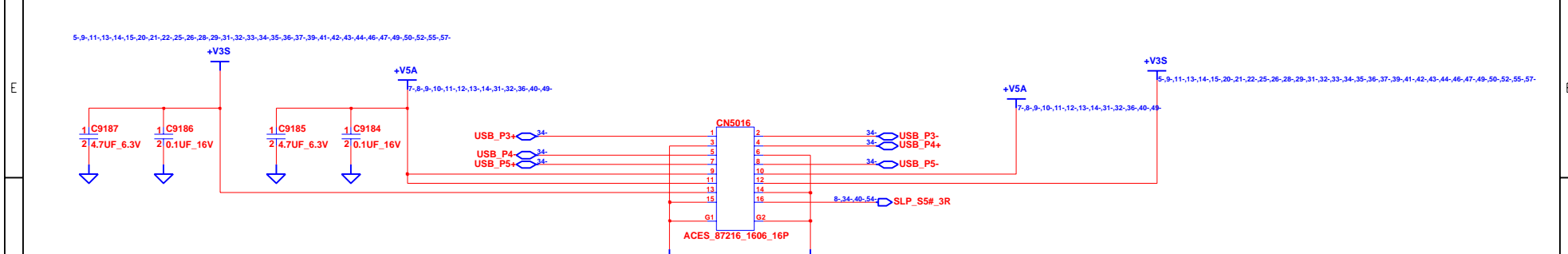

INVENTEC			
TITLE DD1.0 5 IN 1 CONNECTOR			
SIZE A3	CODE CS	DOC. NUMBER <i>Model No</i>	REV A02
CHANGE by <i>MORRIS CHANG</i>		28-Feb-2007	
SHEET 49		OF 60	

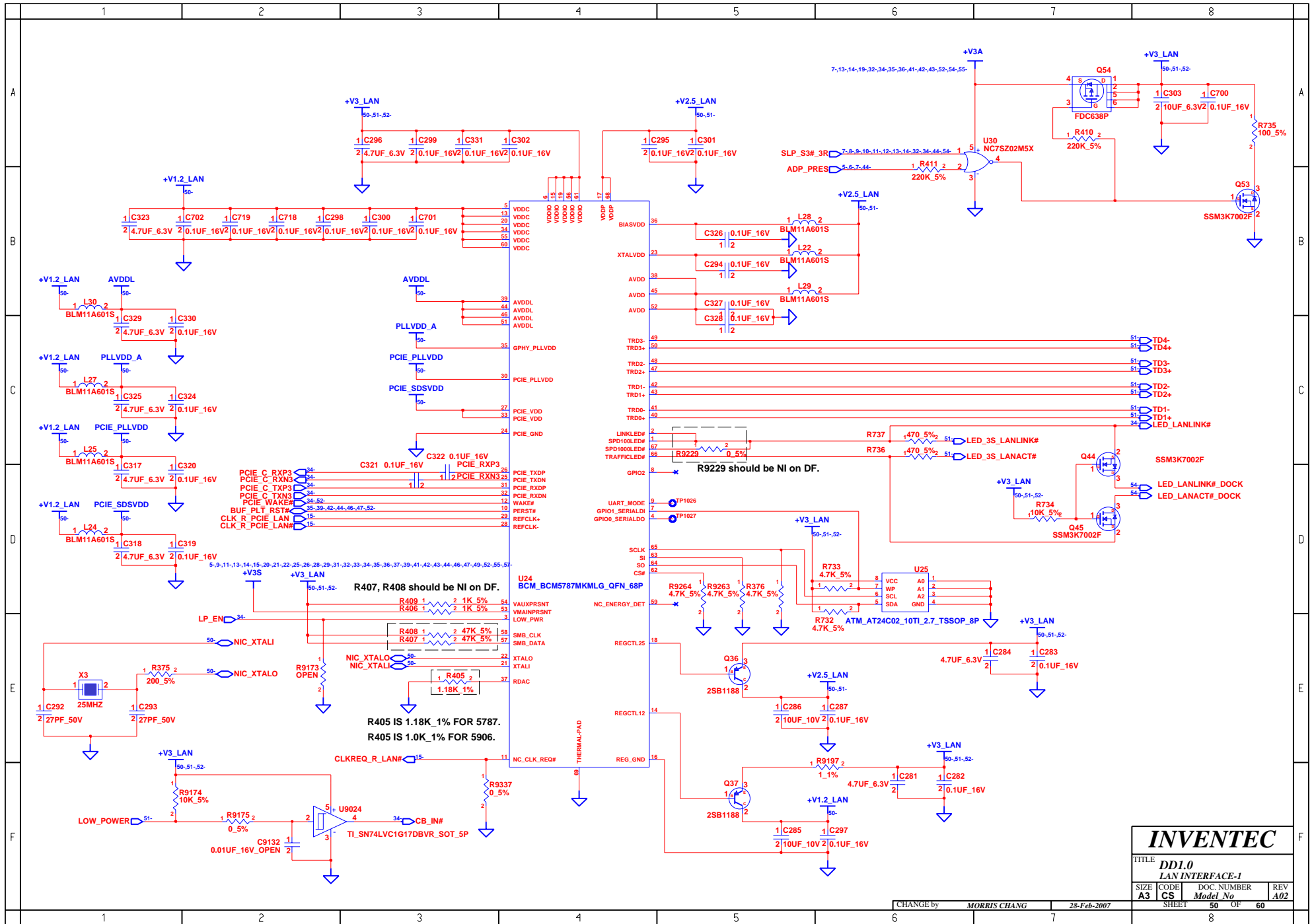

INVENTEC			
TITLE DDI.0 LAN INTERFACE-1			
SIZE A3	CODE CS	DOC. NUMBER Model No	REV A02
CHANGE by MORRIS CHANG		28-Feb-2007	
SHEET 50		OF 60	

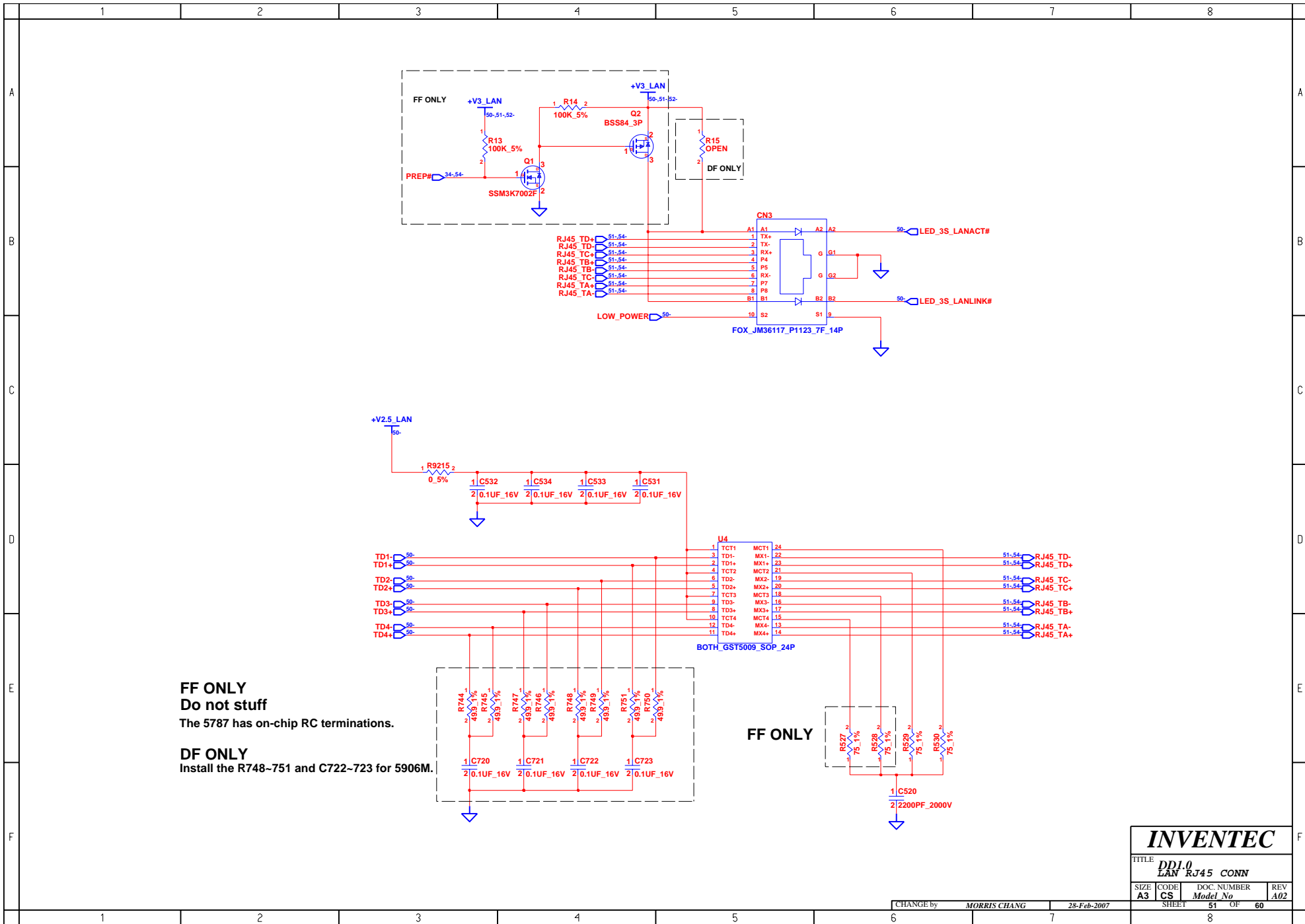

INVENTEC

TITLE			
DDI.0 LAN RJ45 CONN			
SIZE	CODE	DOC. NUMBER	REV
A3	CS	Model No	A02

CHANGE by MORRIS CHANG 28-Feb-2007

SHEET 51 OF 60

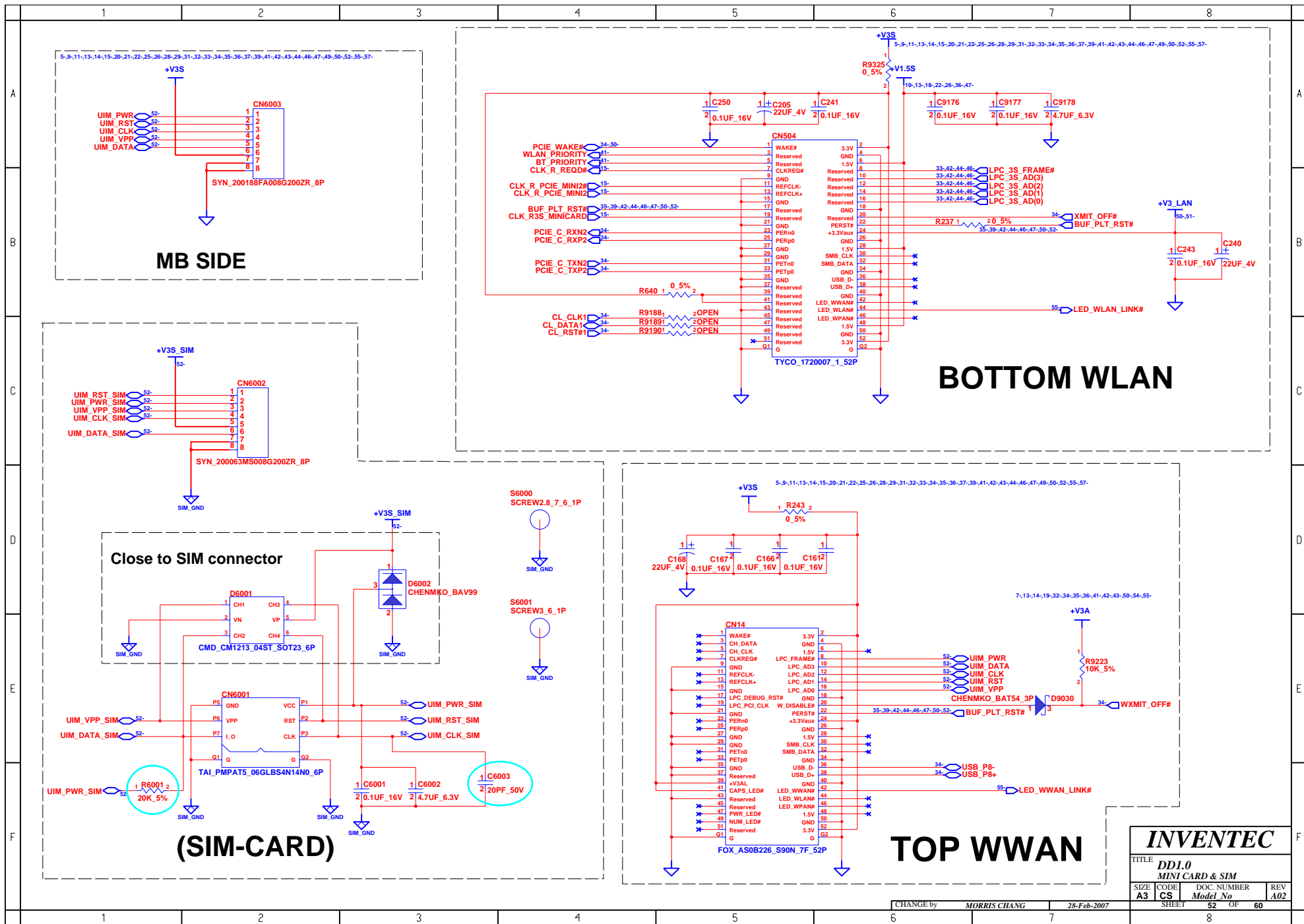

INVENTEC			
TITLE DDI.0 MINI CARD & SIM			
SIZE A3	CODE CS	DOC. NUMBER <i>Model No</i>	REV A02
CHANGE by <i>MORRIS CHANG</i>		28-Feb-2007	
SHEET 52		OF 60	

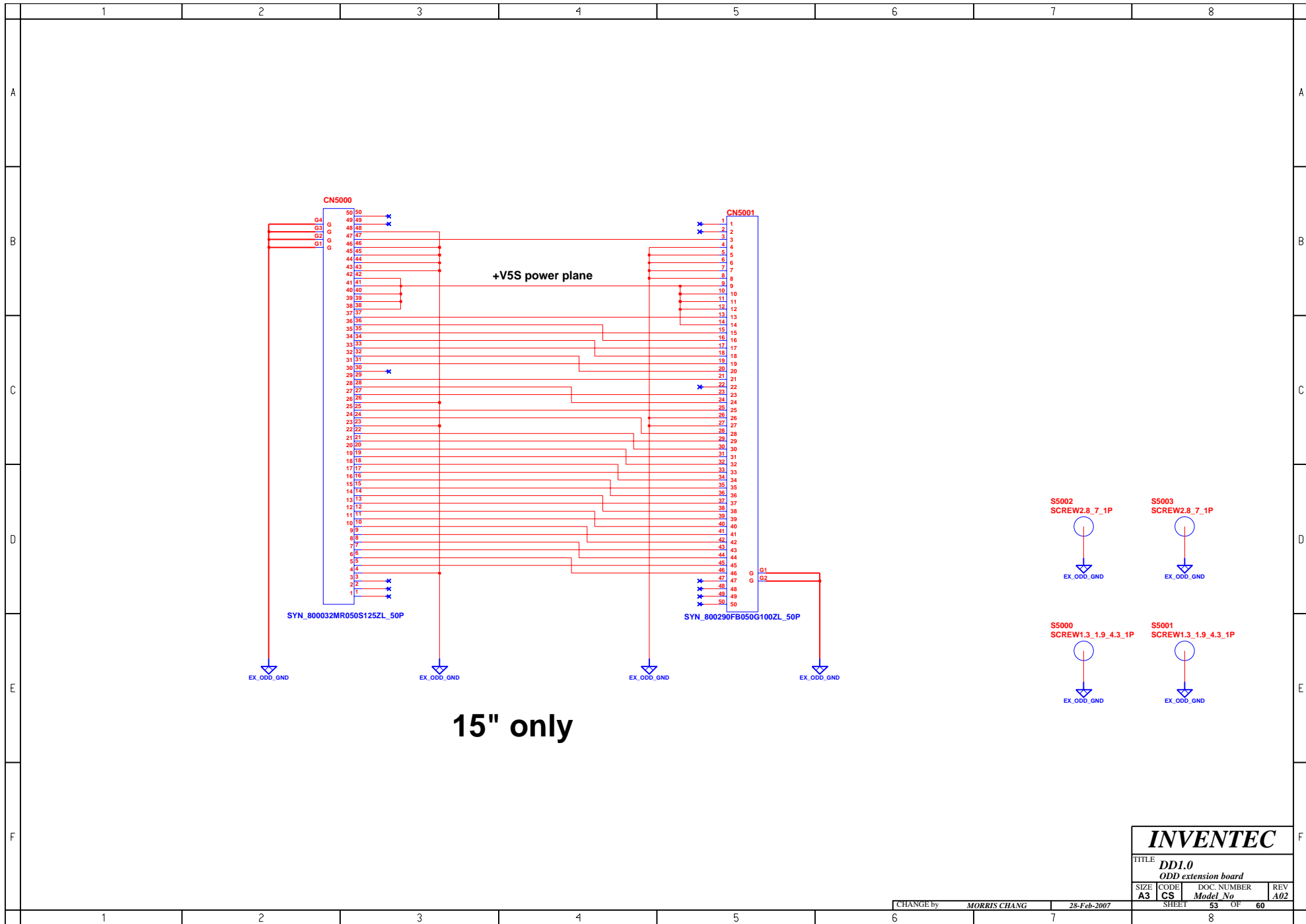

INVENTEC			
TITLE DD1.0 <i>ODD extension board</i>			
SIZE A3	CODE CS	DOC. NUMBER <i>Model No</i>	REV A02
CHANGE by <i>MORRIS CHANG</i>		28-Feb-2007	
SHEET 53		OF 60	

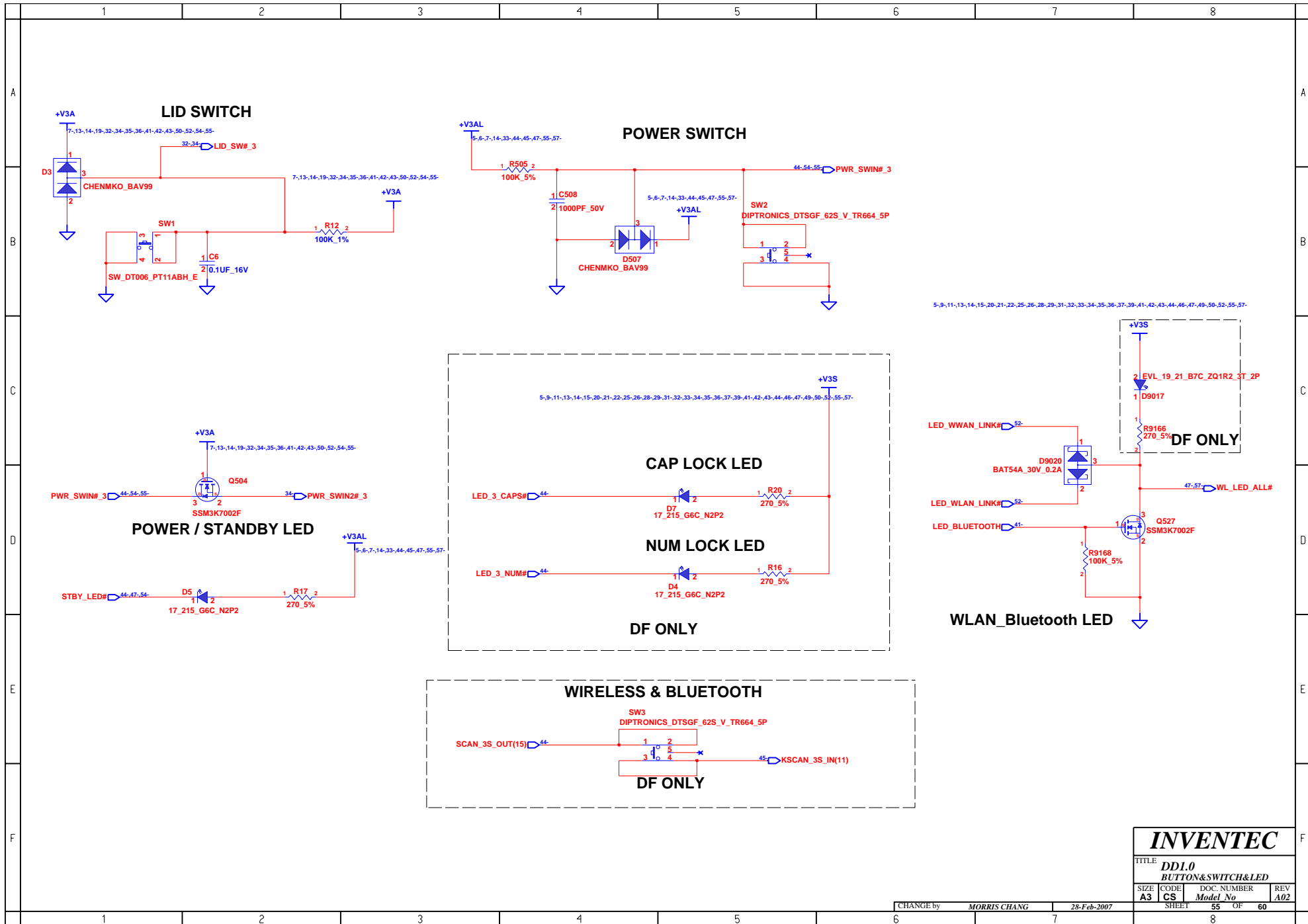

INVENTEC

TITLE			
DD1.0			
BUTTON&SWITCH&LED			
SIZE	CODE	DOC. NUMBER	REV
A3	CS	Model No	A02
CHANGE by		SHEET	
MORRIS CHANG		55 OF 60	

28-Feb-2007

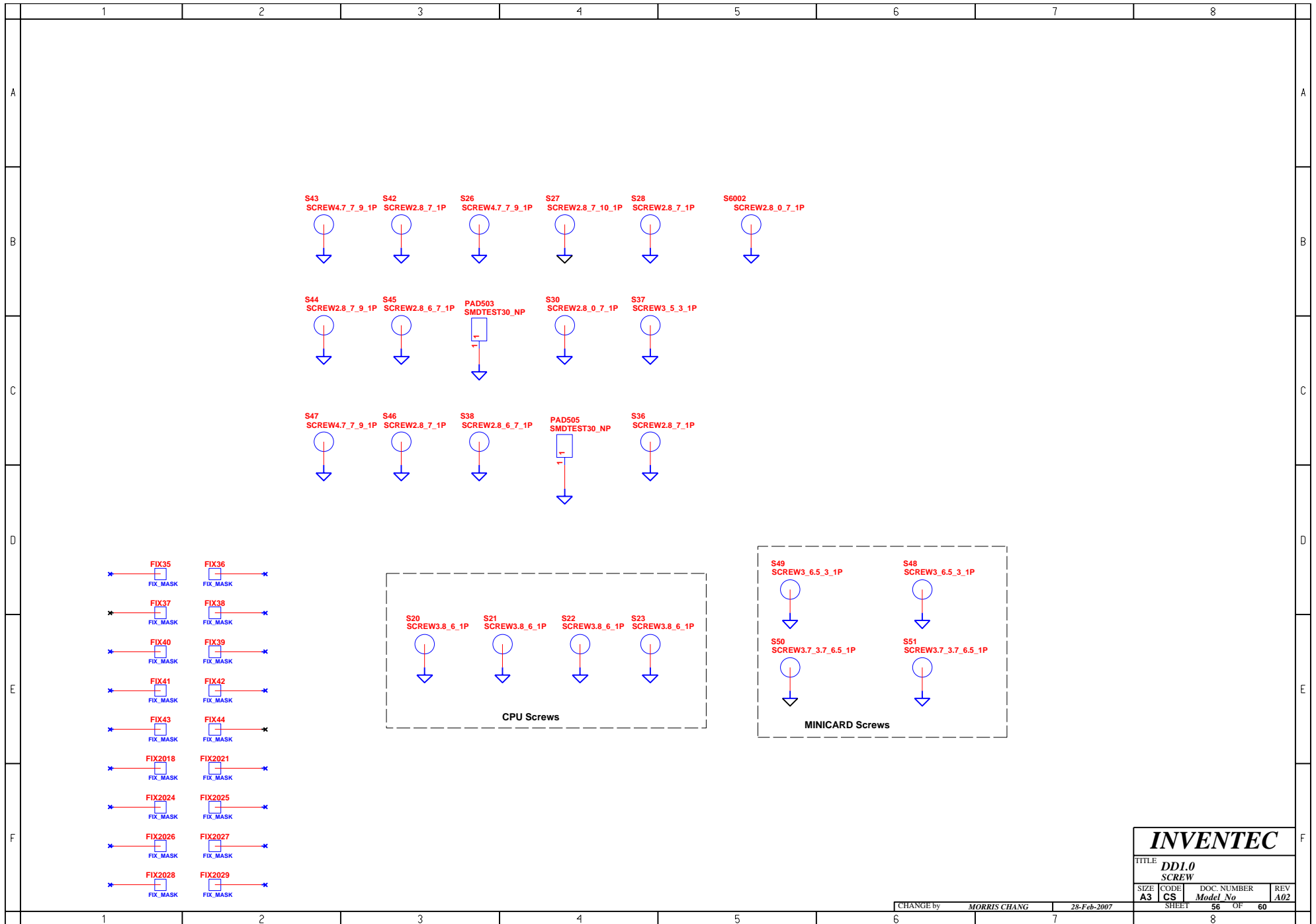

INVENTEC			
TITLE DD1.0			
SCREW			
SIZE A3	CODE CS	DOC. NUMBER <i>Model No</i>	REV A02
CHANGE by <i>MORRIS CHANG</i>		28-Feb-2007	
SHEET 56		OF 60	

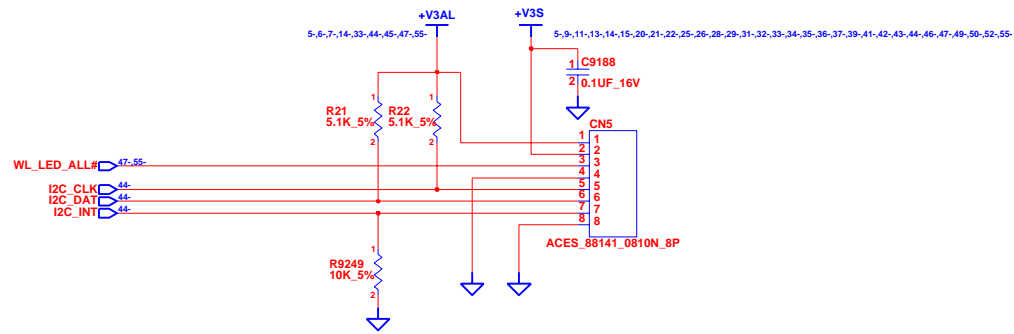

**FF ONLY
SWITCH BOARD CONN**

INVENTEC			
TITLE DD1.0 Switch board Conn			
SIZE A3	CODE CS	DOC. NUMBER Model No	REV A02
CHANGE by MORRIS CHANG		28-Feb-2007	
SHEET		57	OF 60

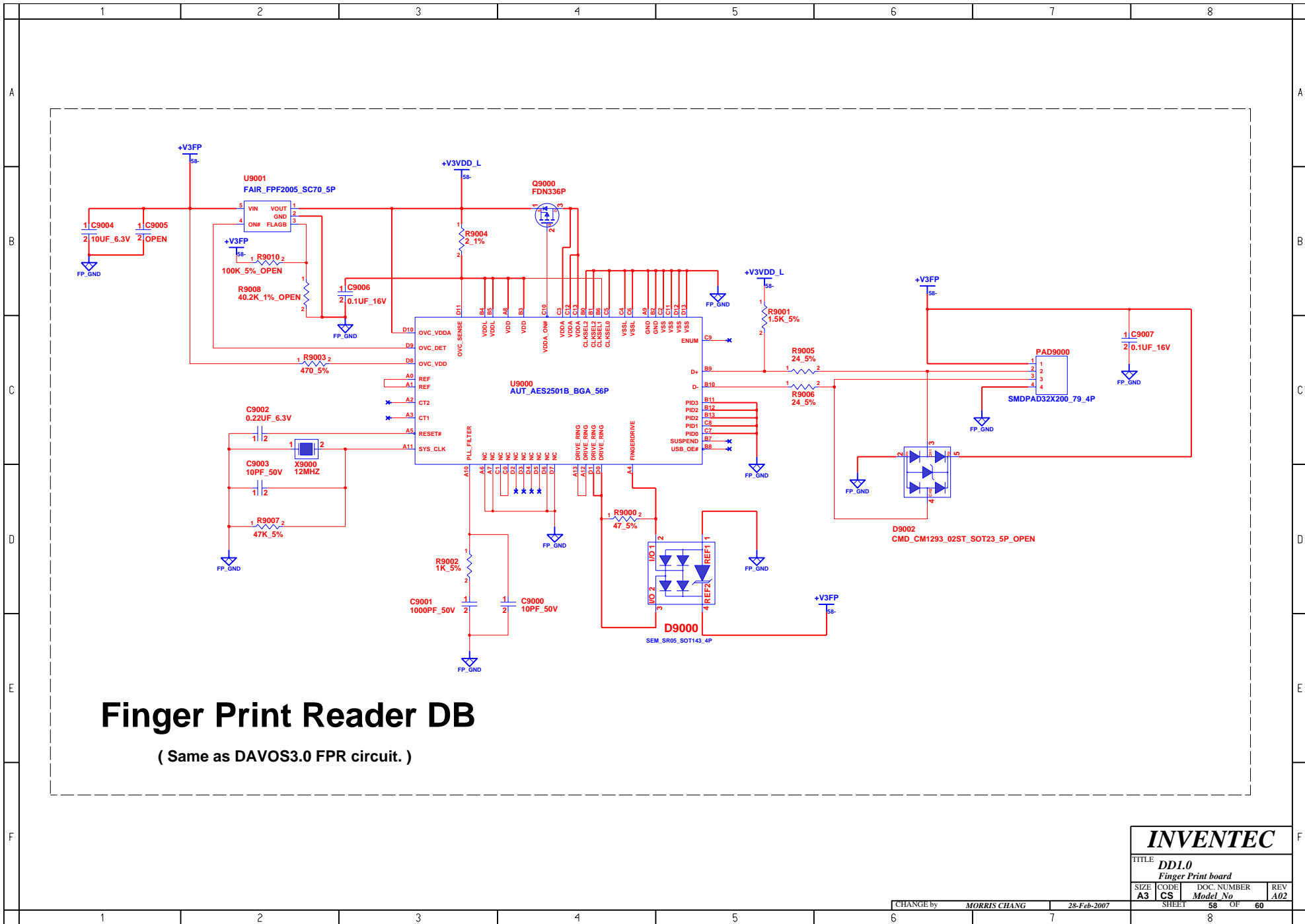

INVENTEC

TITLE			
DD1.0			
Finger Print board			
SIZE	CODE	DOC. NUMBER	REV
A3	CS	Model No	A02

CHANGE by MORRIS CHANG 28-Feb-2007

SHEET 58 OF 60

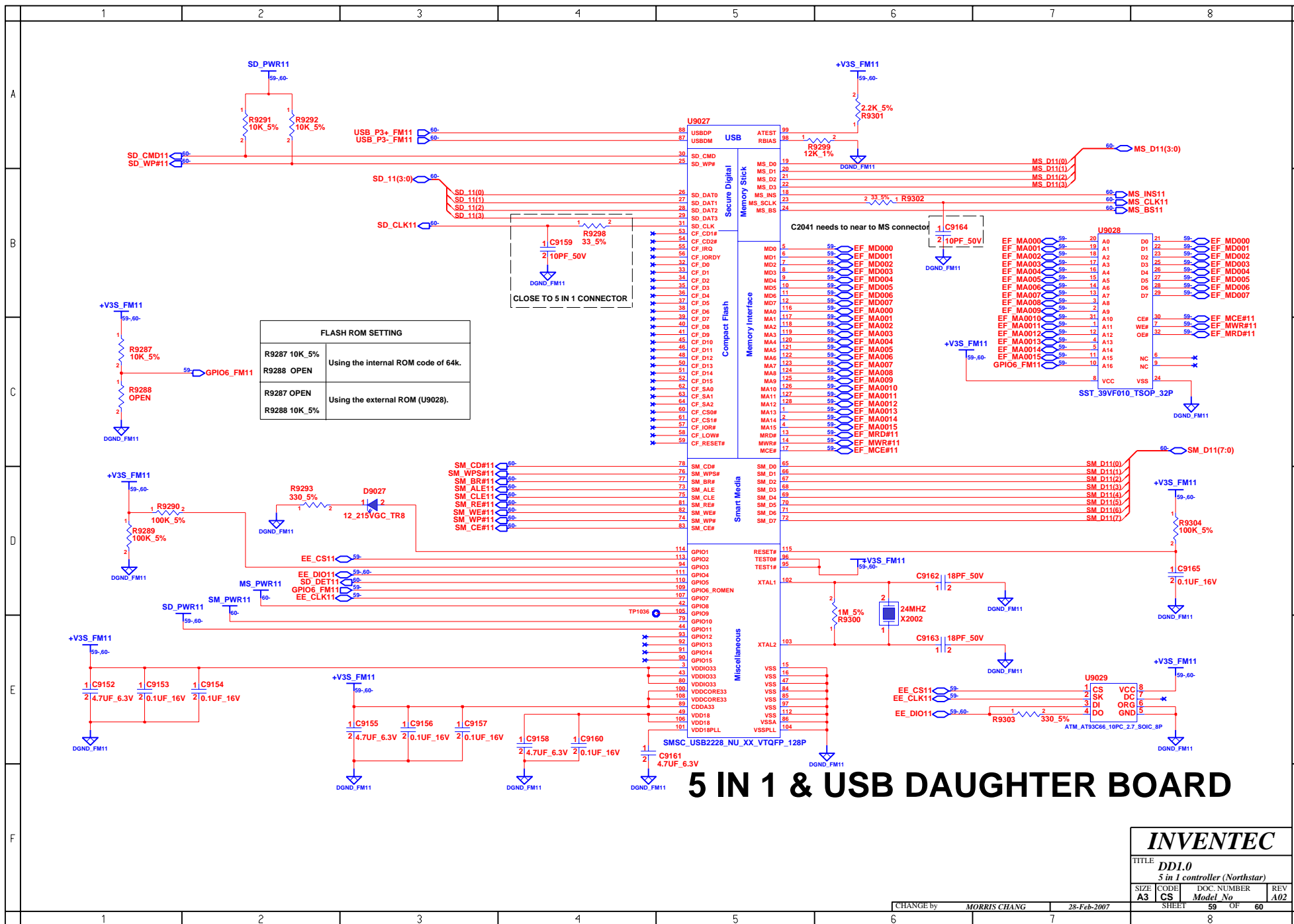

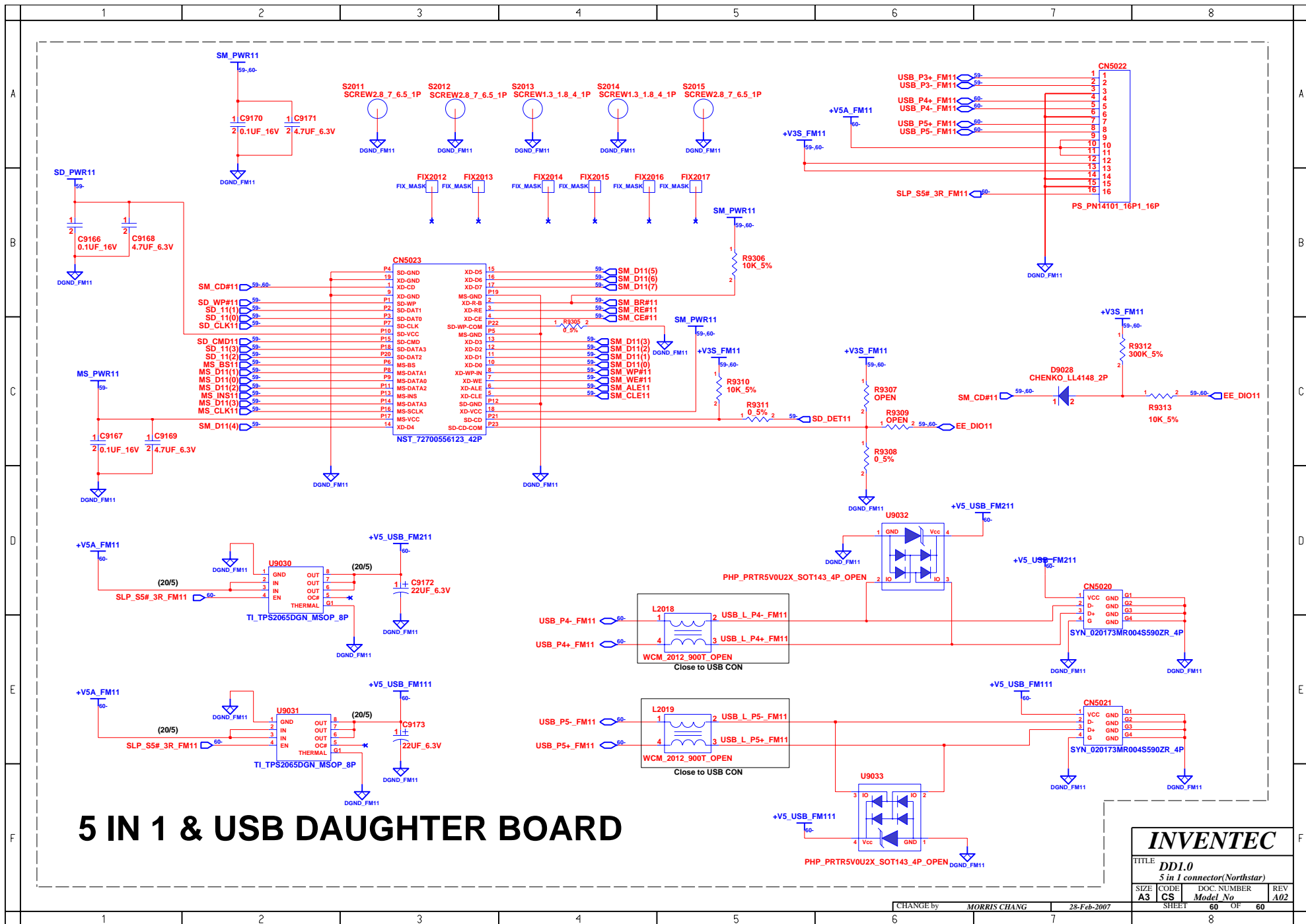

5 IN 1 & USB DAUGHTER BOARD

INVENTEC			
TITLE DD1.0 5 in 1 connector(Northstar)			
SIZE A3	CODE CS	DOC. NUMBER Model No	REV A02
CHANGE by MORRIS CHANG		28-Feb-2007	
SHEET 60		OF 60	