



**Table Of Content**

PAGE	PAGE	PAGE
5- DC& Battery Charger	30- SB600-1	55- Finger Print board
6- Selector & Battery CONN	31- SB600-2	56- BLANK
7- +V5A, +V3A & +V1.8S	32- SB600-3	57- ODD extension board
8- OCP	33- SB600-4	58- SW/B connector
9- +VCC_NB & V1.2S	34- KBC	59- SIM board
10- +VCC_CORE	35- SPI & Accelerometer	60- 5 in 1 Second source
11- DDR2 POWER	36- INT. KBC/Touch Pad Devices	61- 5 in 1 Second source (New)
12- Power(Sleep)	37- Super I/O	
13- Power(Sequence)	38- TPM V1.2	
14- Clock Generator	39- HDD CONN (SATA)	
15- AMD CPU-1	40- Fixed ODD CONN (PATA)	
16- AMD CPU-2	41- USB CONN	
17- AMD CPU-3	42- CB/D CONN	
18- AMD CPU-4	43- BLANK	
19- Thermal & Fan Controller	44- 5 IN 1 CONN	
20- RS690T -1	45- MiniCard	
21- RS690T -2	46- LAN Interface	
22- RS690T -3	47- LAN RJ45 CONN	
23- RS690T -4	48- Docking CONN	
24- DDR2-DIMM0	49- Screw	
25- DDR2-DIMM1	50- Finger Print DB	
26- DDR2-DAMPING	51- BlueTooth	
27- VIDEO MEMORY	52- Power/LID Switch & LED	
28- CRT& S-Vedio CONN	53- 5 in 1 Main source	
29- LCD CONN	54- 5 in 1 Main source (Northstar)	

**INVENTEC**

TITLE *TT1.0*

SIZE <b>A3</b>	CODE <b>CS</b>	DOC. NUMBER <i>1310A21421-0</i>	REV <b>A02</b>
-------------------	-------------------	------------------------------------	-------------------

CHANGE by *Jimmy song* 2-Mar-2007 SHEET 2 OF 61

# Inventec Confidential

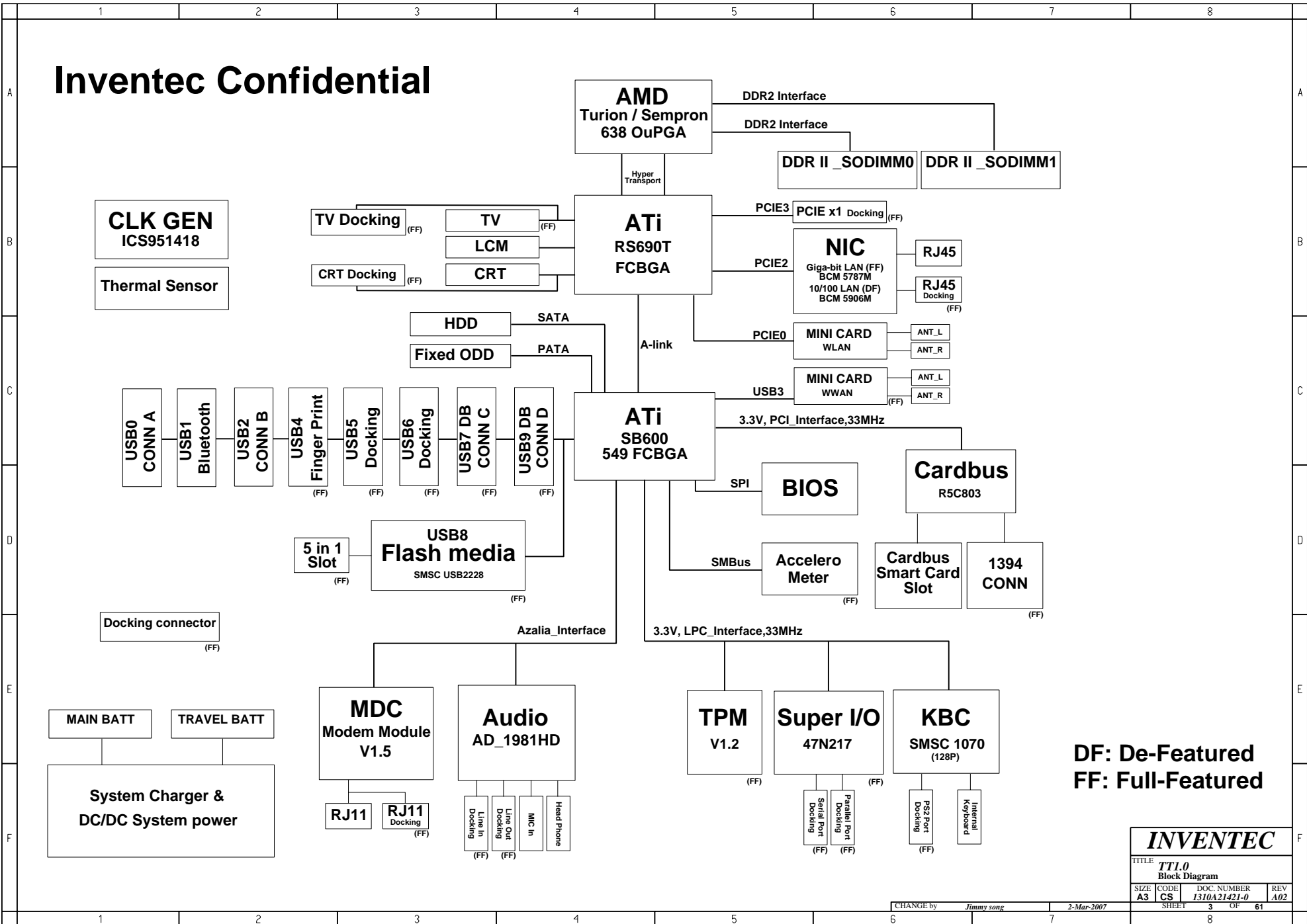

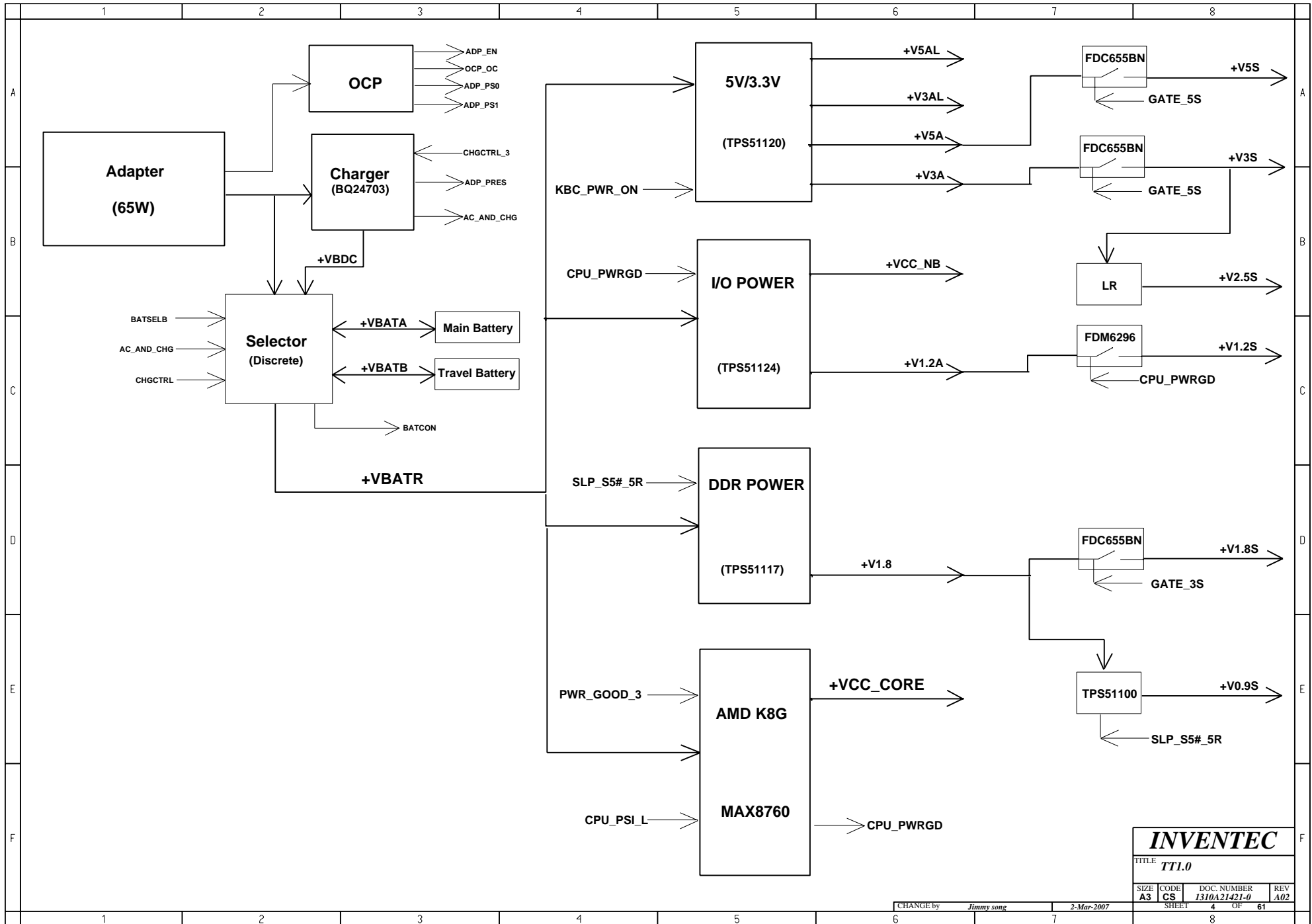

<b>INVENTEC</b>			
TITLE <i>TT1.0</i>			
SIZE	CODE	DOC. NUMBER	REV
A3	CS	1310A21421-0	A02
CHANGE by <i>Jimmy song</i>		2-Mar-2007	
SHEET 4		OF 61	

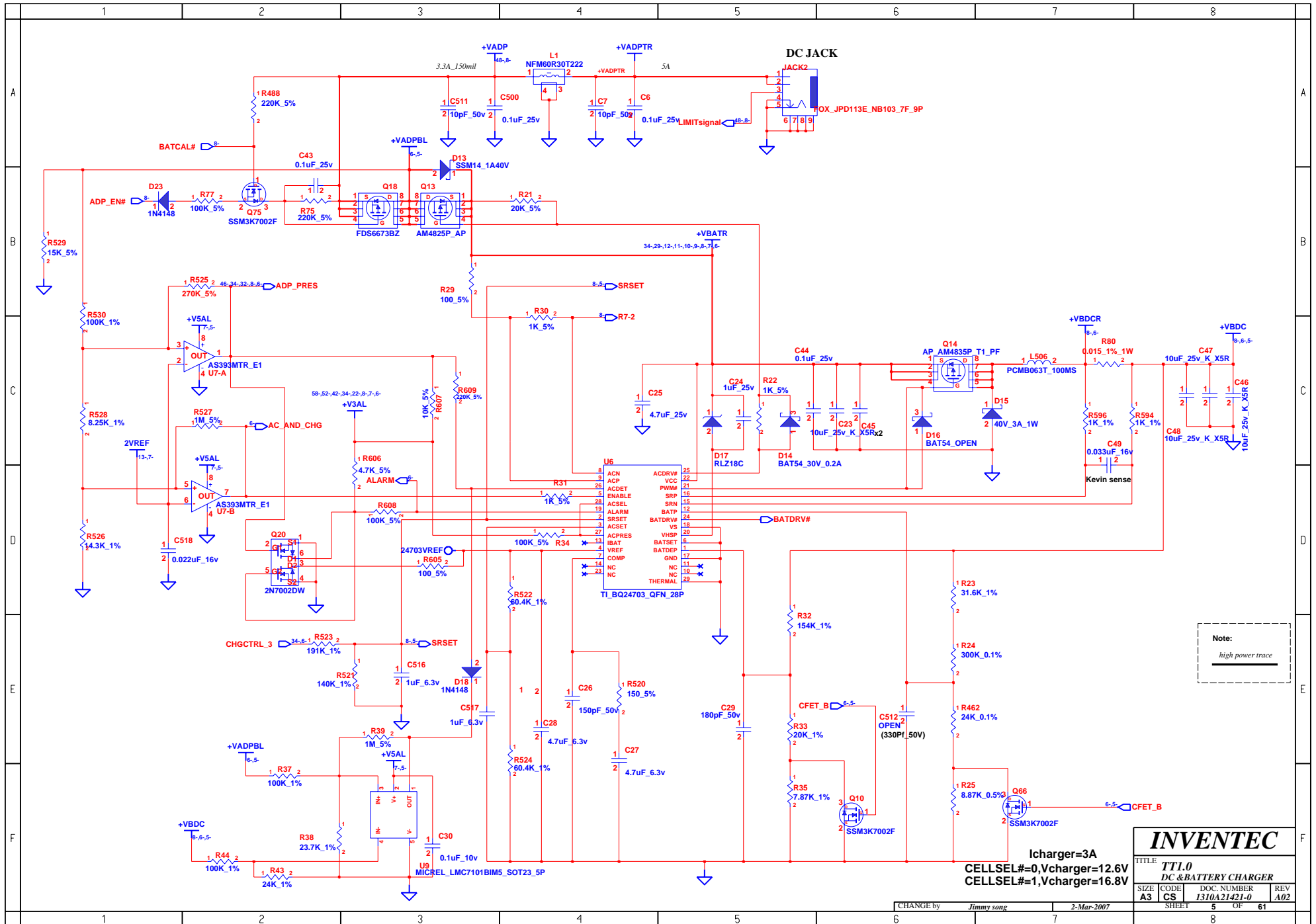

Note:  
high power trace

Icharger=3A  
CELLSEL#=0, Vcharger=12.6V  
CELLSEL#=1, Vcharger=16.8V

<b>INVENTEC</b>			
TITLE TT1.0			
DC & BATTERY CHARGER			
SIZE A3	CODE CS	DOC. NUMBER 1310A21421-0	REV A02
CHANGE by Jimmy song		2-Mar-2007	
SHEET 5		OF 61	



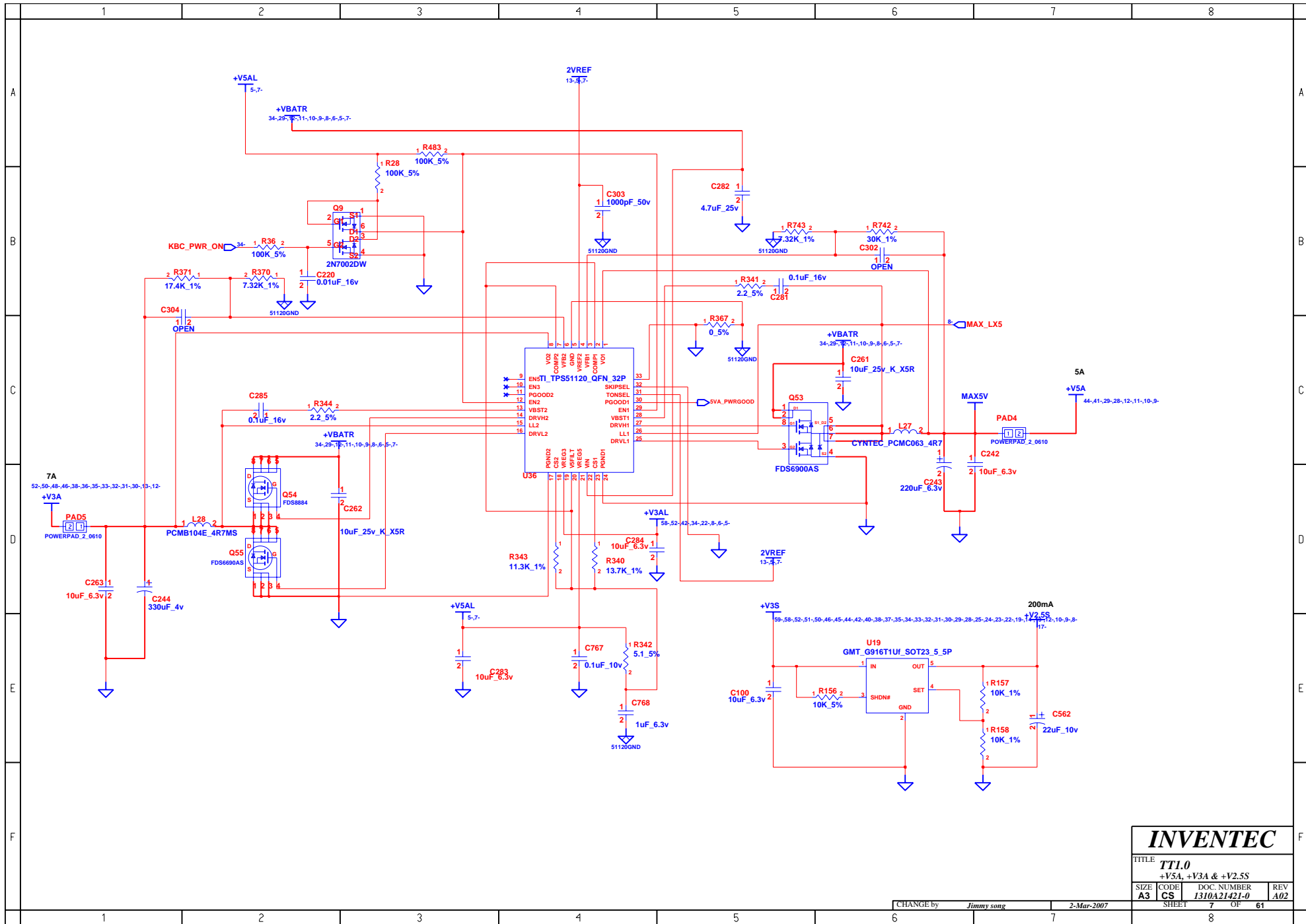

<b>INVENTEC</b>			
TITLE <b>TT1.0</b>			
+V5A, +V3A & +V2.5S			
SIZE <b>A3</b>	CODE <b>CS</b>	DOC. NUMBER <b>I310A21421-0</b>	REV <b>A02</b>

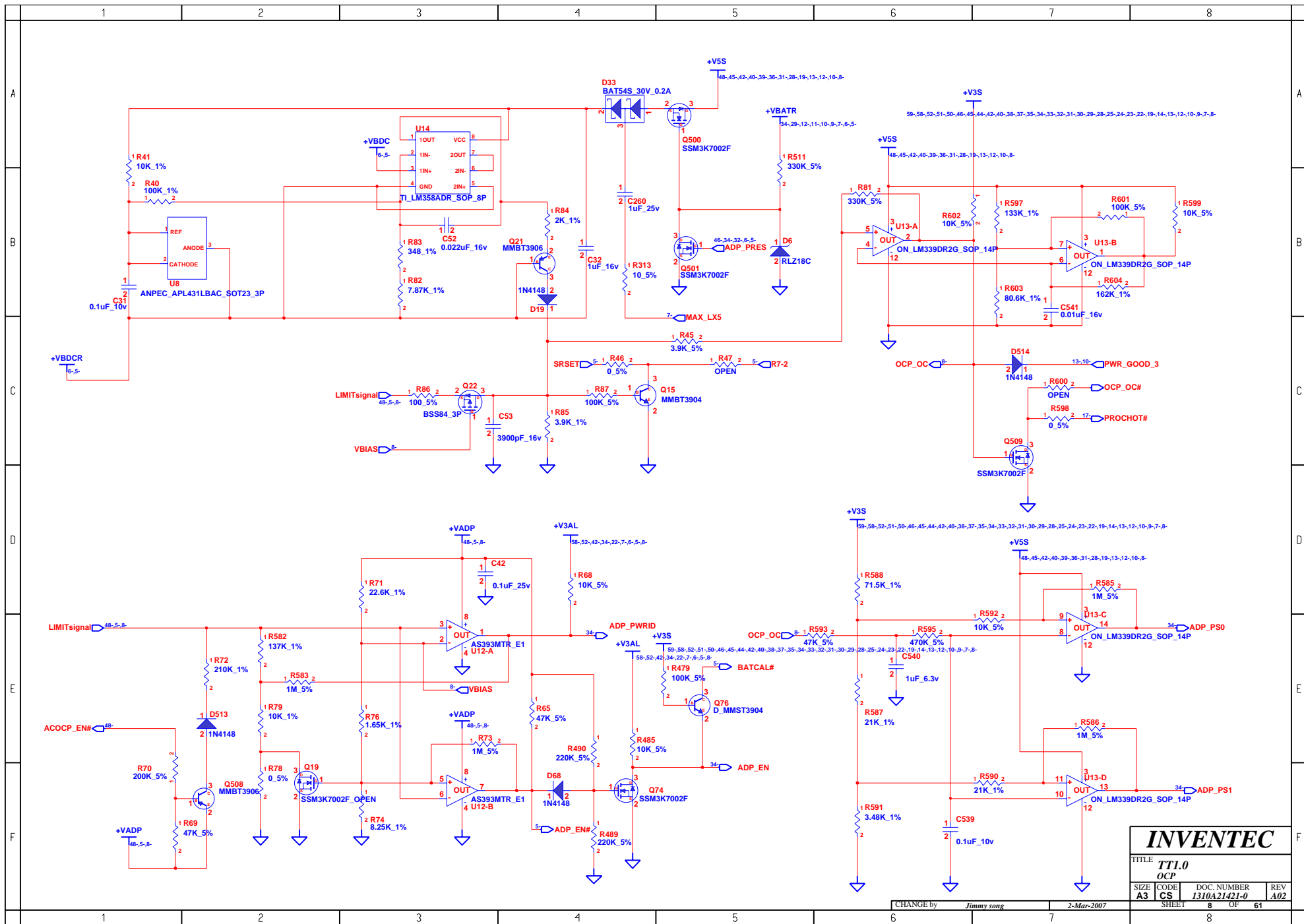

<b>INVENTEC</b>			
TITLE TTI.0			
OCP			
SIZE A3	CODE CS	DOC. NUMBER 1310A21421-0	REV A02
CHANGE by Jimmy song		2-Mar-2007	
SHEET 8		OF 61	

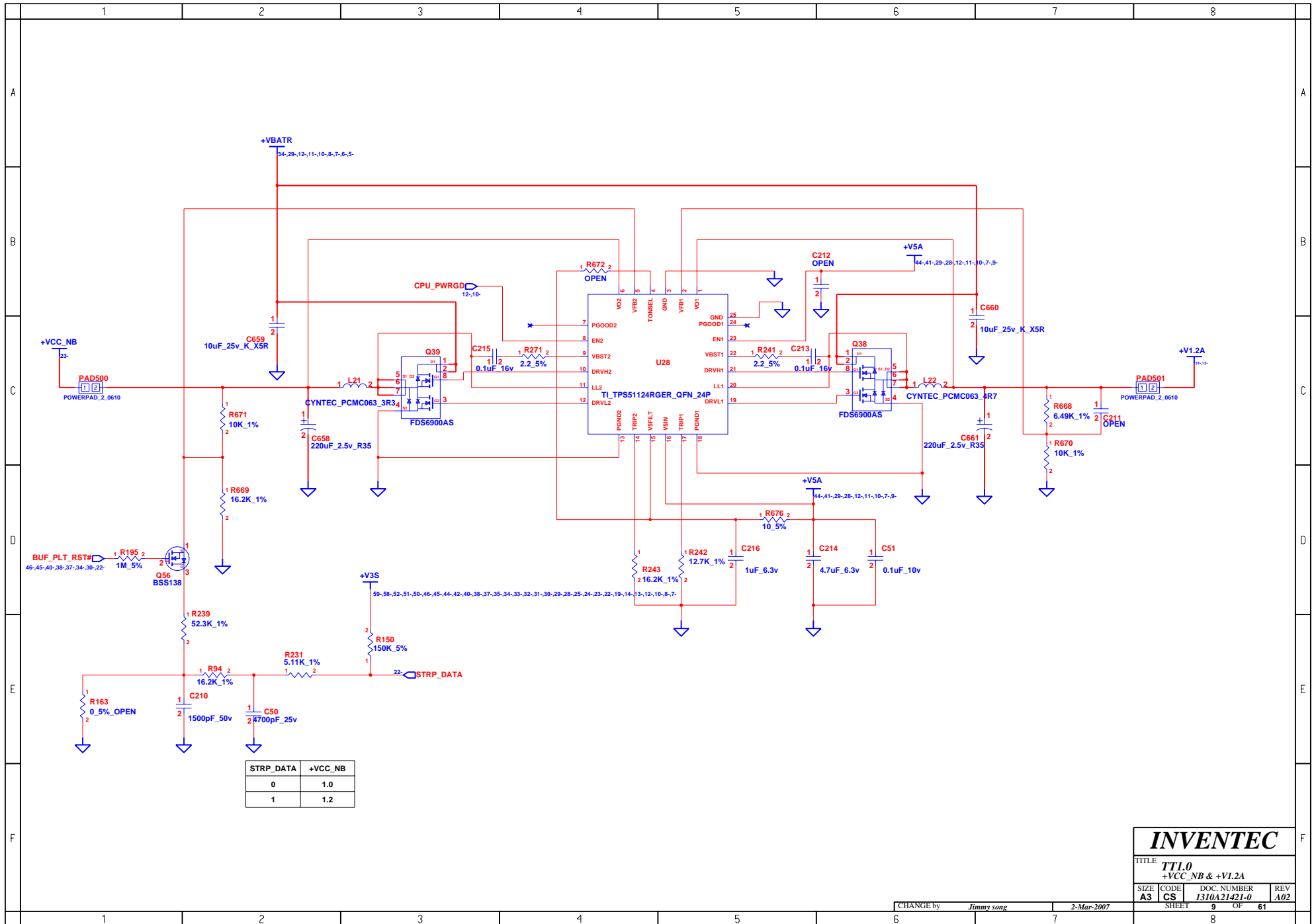

**INVENTEC**

TITLE <b>TTL0</b> <b>+VCC_NB &amp; +V1.2A</b>		
SIZE <b>A3</b>	CODE <b>CS</b>	DOC. NUMBER <b>1310A21421-0</b>
SHEET <b>9</b>		REV <b>A02</b>



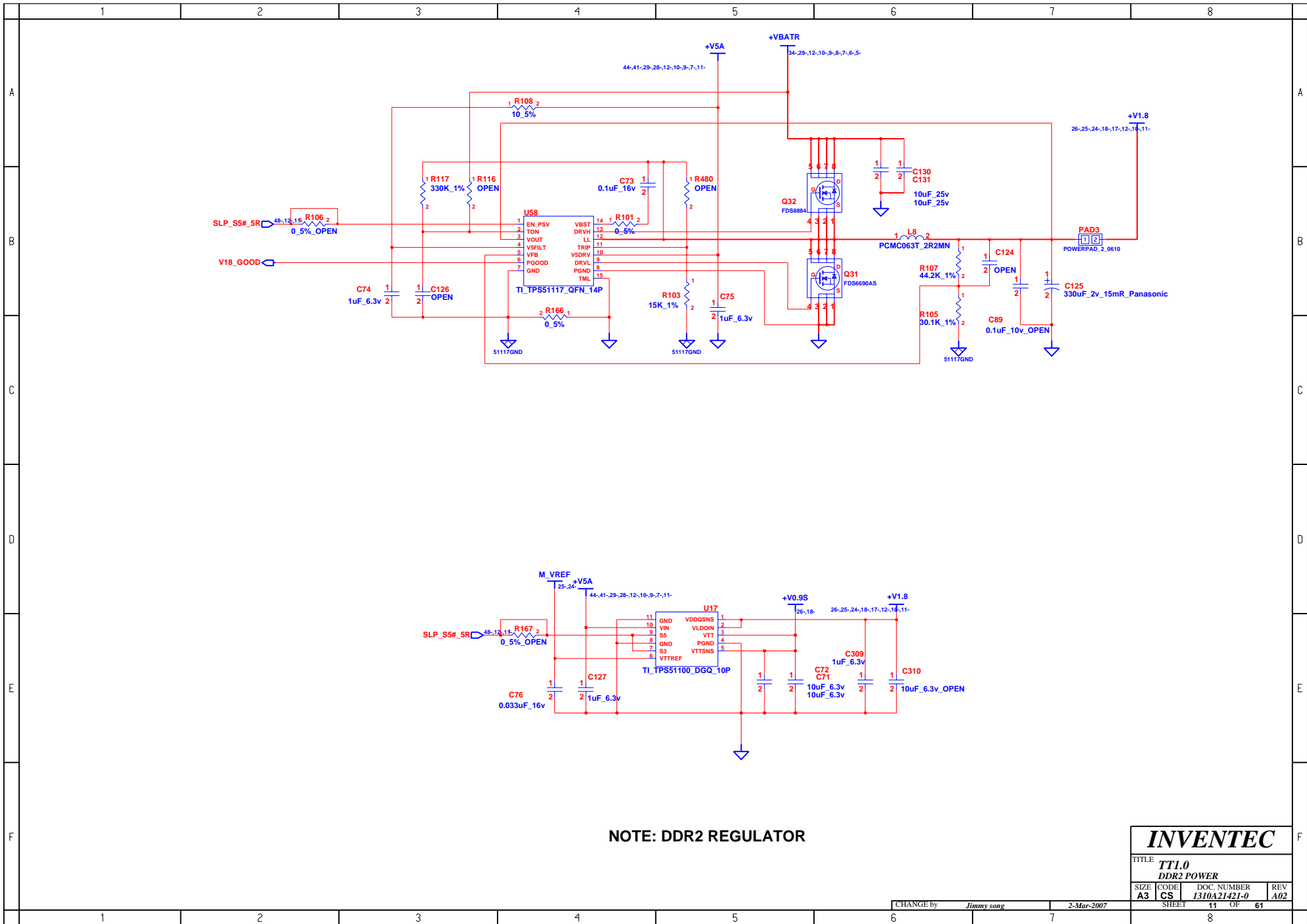

NOTE: DDR2 REGULATOR

**INVENTEC**

TITLE			
T11.0			
DDR2 POWER			
SIZE	CODE	DOC. NUMBER	REV
A3	CS	I310A21421-0	A02

CHANGE by	Jimmy song	2-Mar-2007	SHEET	11	OF	61
-----------	------------	------------	-------	----	----	----

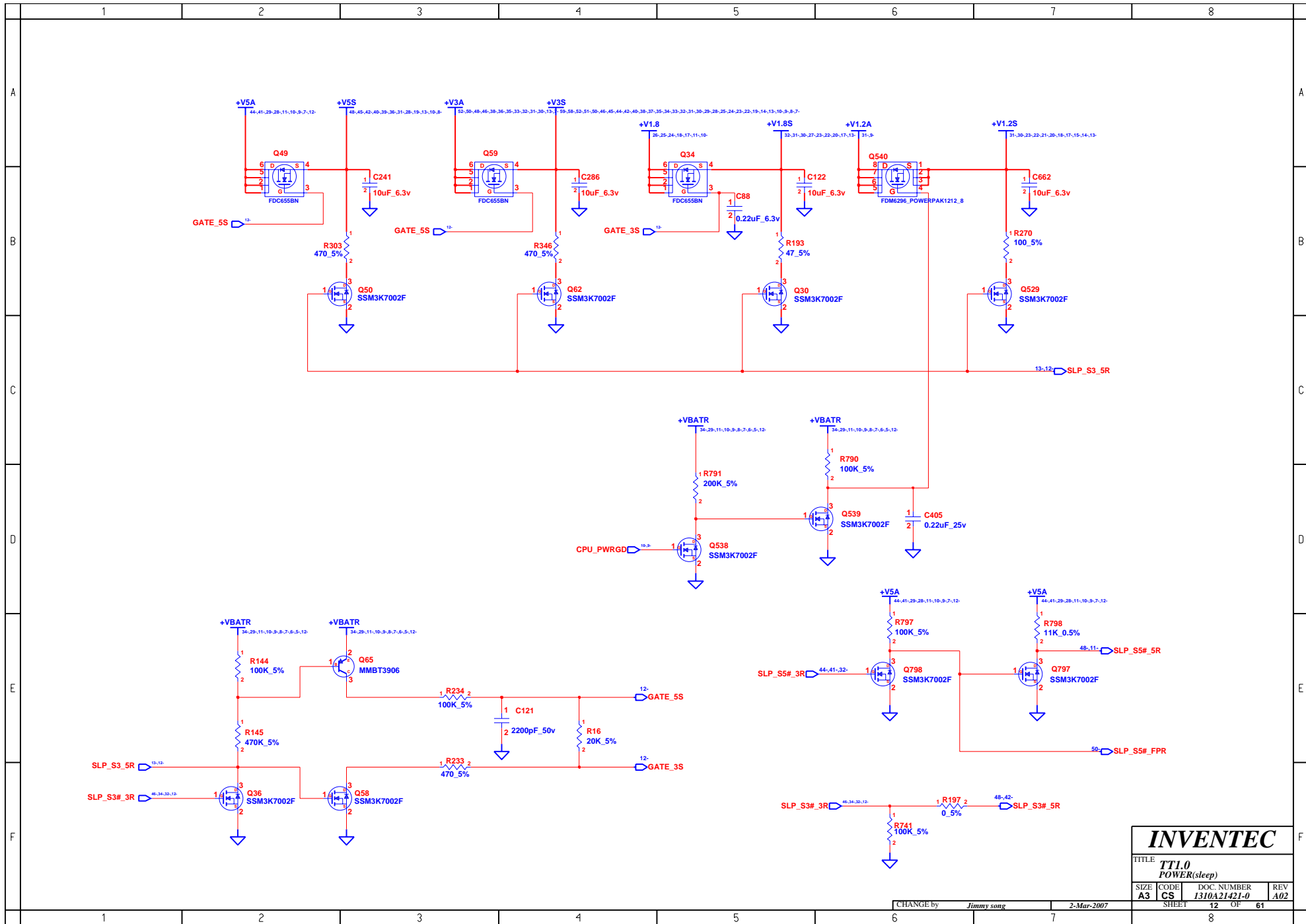

<b>INVENTEC</b>			
TITLE <i>TTL0</i> <i>POWER(sleep)</i>			
SIZE <b>A3</b>	CODE <b>CS</b>	DOC. NUMBER <b>I310A21421-0</b>	REV <b>A02</b>
CHANGE by <i>Jimmy song</i>		2-Mar-2007	
SHEET <b>12</b>		OF <b>61</b>	

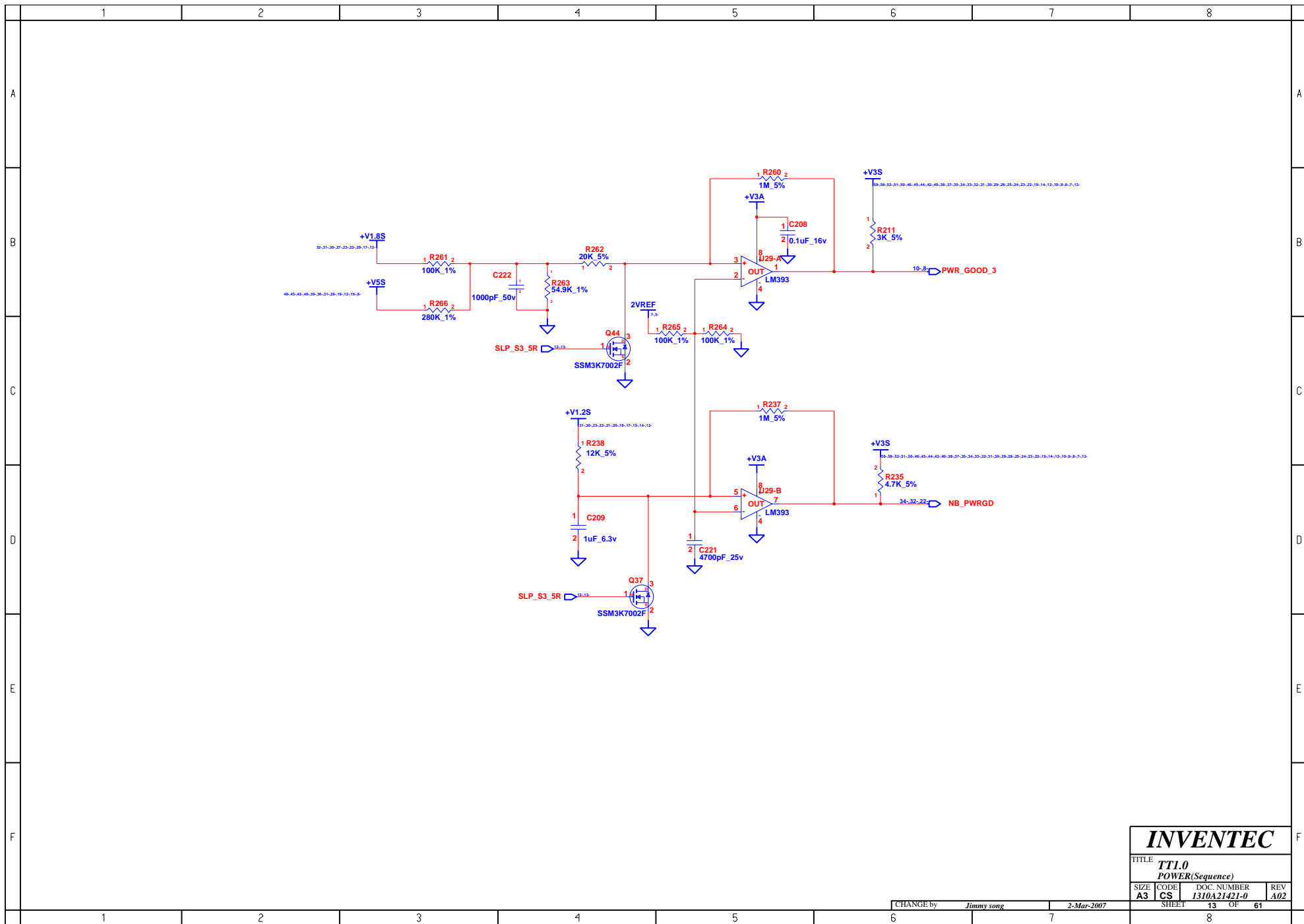

**INVENTEC**

TITLE			
TT1.0			
POWER(Sequence)			
SIZE	CODE	DOC. NUMBER	REV
A3	CS	1310A21421-0	A02

CHANGE by	Jimmy song	2-Mar-2007	SHEET	13	OF	61
-----------	------------	------------	-------	----	----	----

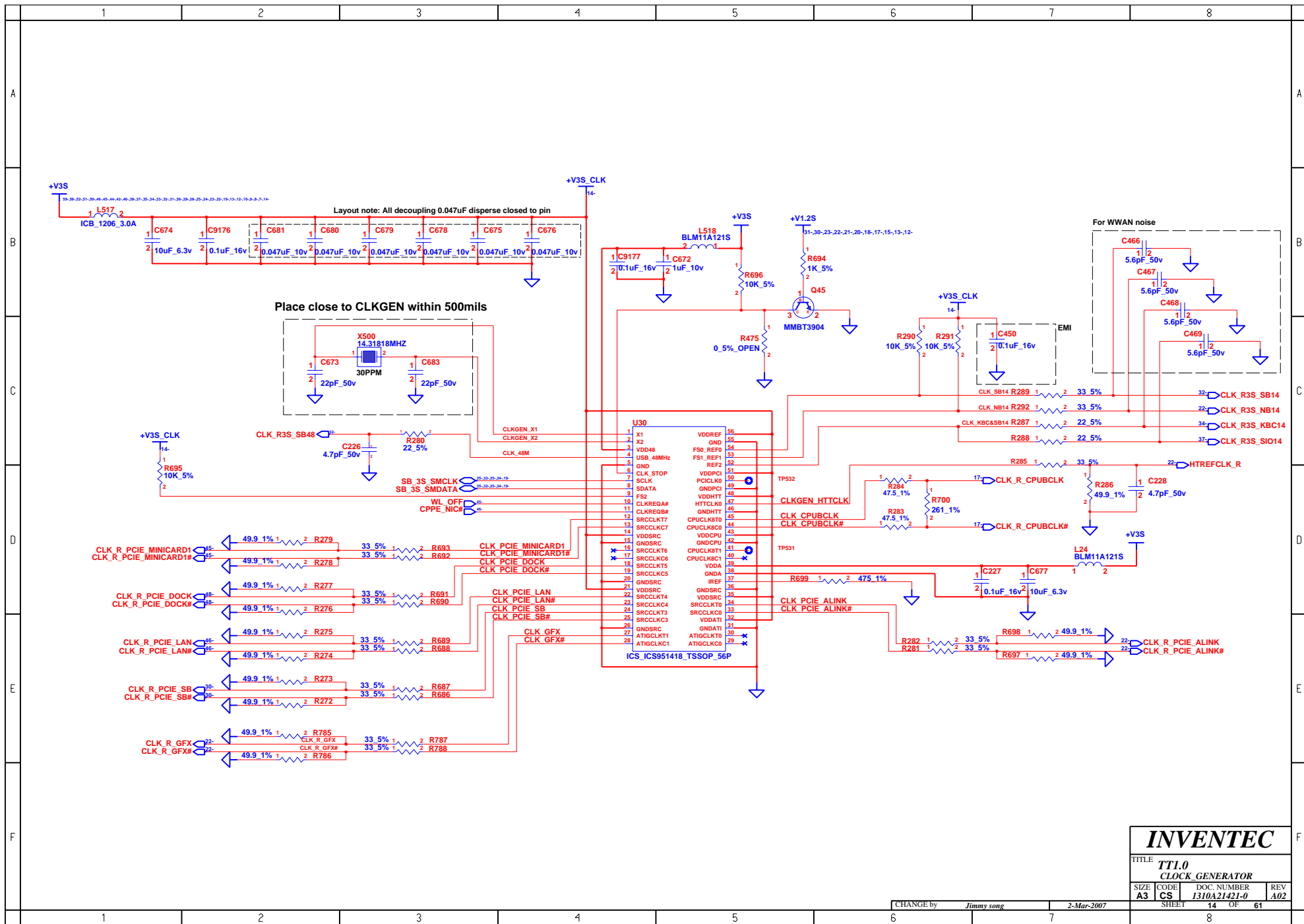

# INVENTEC

TITLE			
TT1.0			
CLOCK_GENERATOR			
SIZE	CODE	DOC. NUMBER	REV
A3	CS	I310A21421-0	A02
CHANGE by		SHEET	
Jimmy song		14 OF 61	

2-Mar-2007

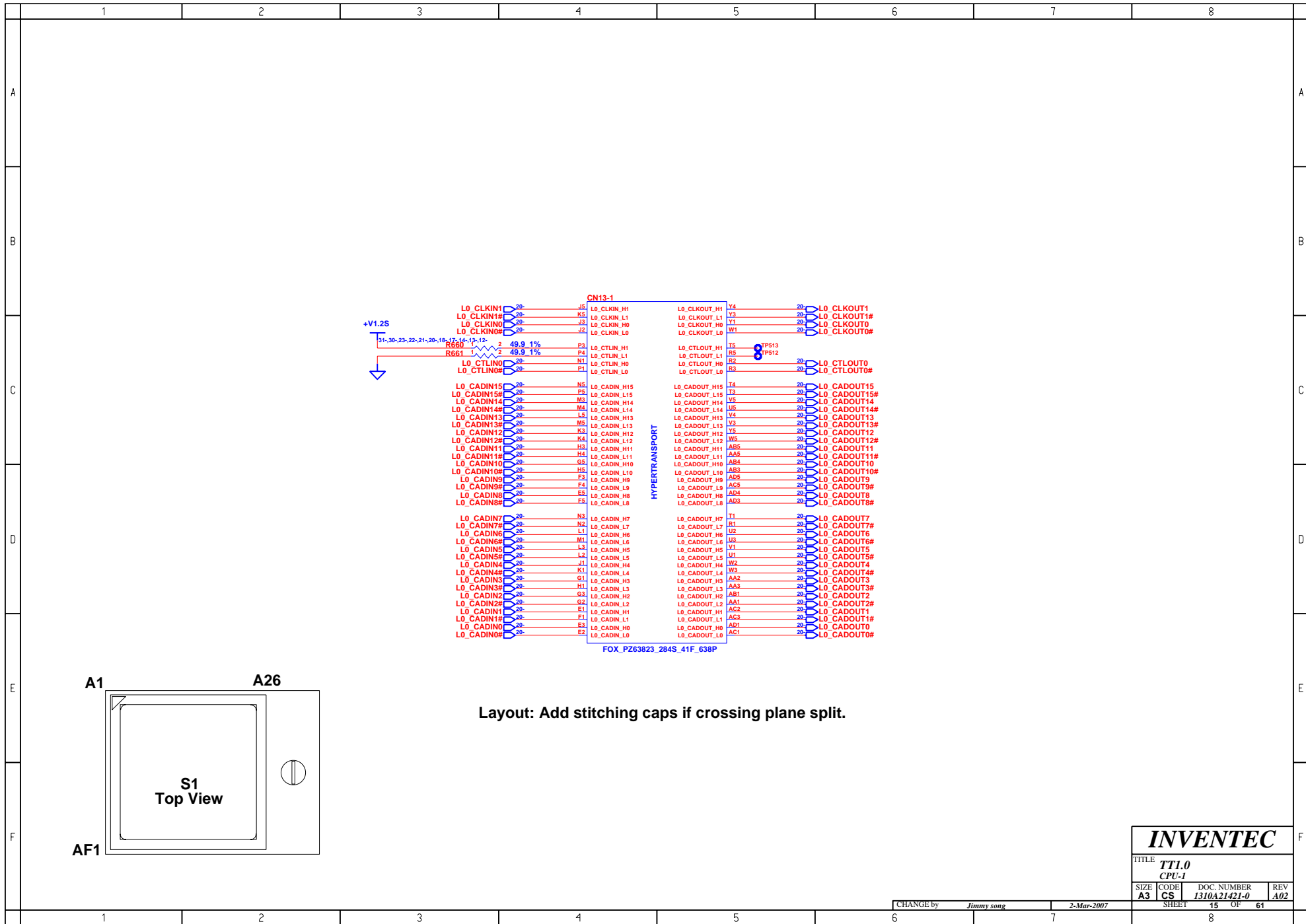

<b>INVENTEC</b>			
TITLE <i>TTL0</i> <i>CPU-1</i>			
SIZE <b>A3</b>	CODE <b>CS</b>	DOC. NUMBER <i>1310A21421-0</i>	REV <b>A02</b>
CHANGE by <i>Jimmy song</i>		2-Mar-2007	
SHEET		15	OF 61

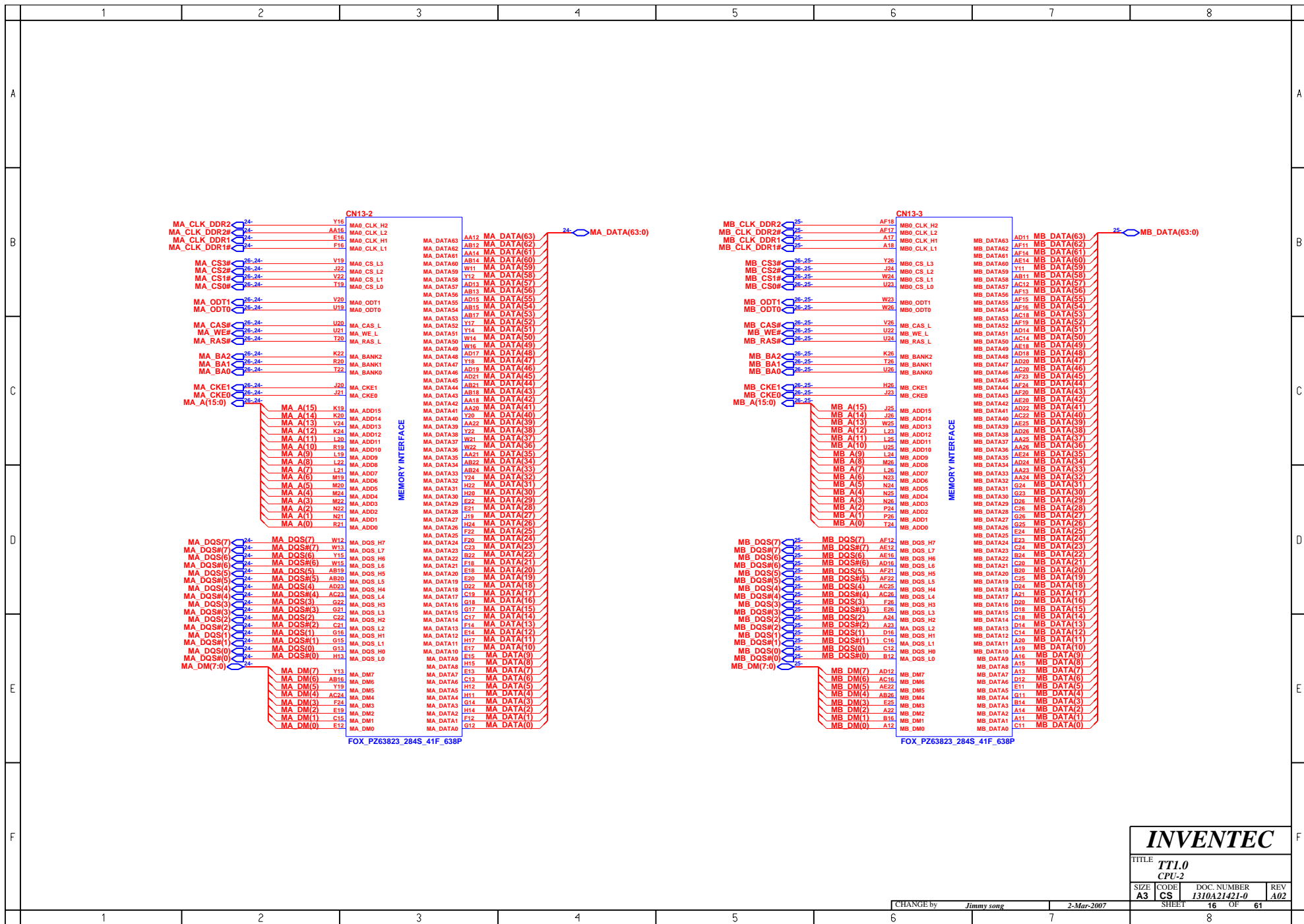

**INVENTEC**

TITLE  
TTI.0  
CPU-2

SIZE A3	CODE CS	DOC. NUMBER 1310A21421-0	REV A02
------------	------------	-----------------------------	------------

CHANGE by Jimmy song 2-Mar-2007 SHEET 16 OF 61



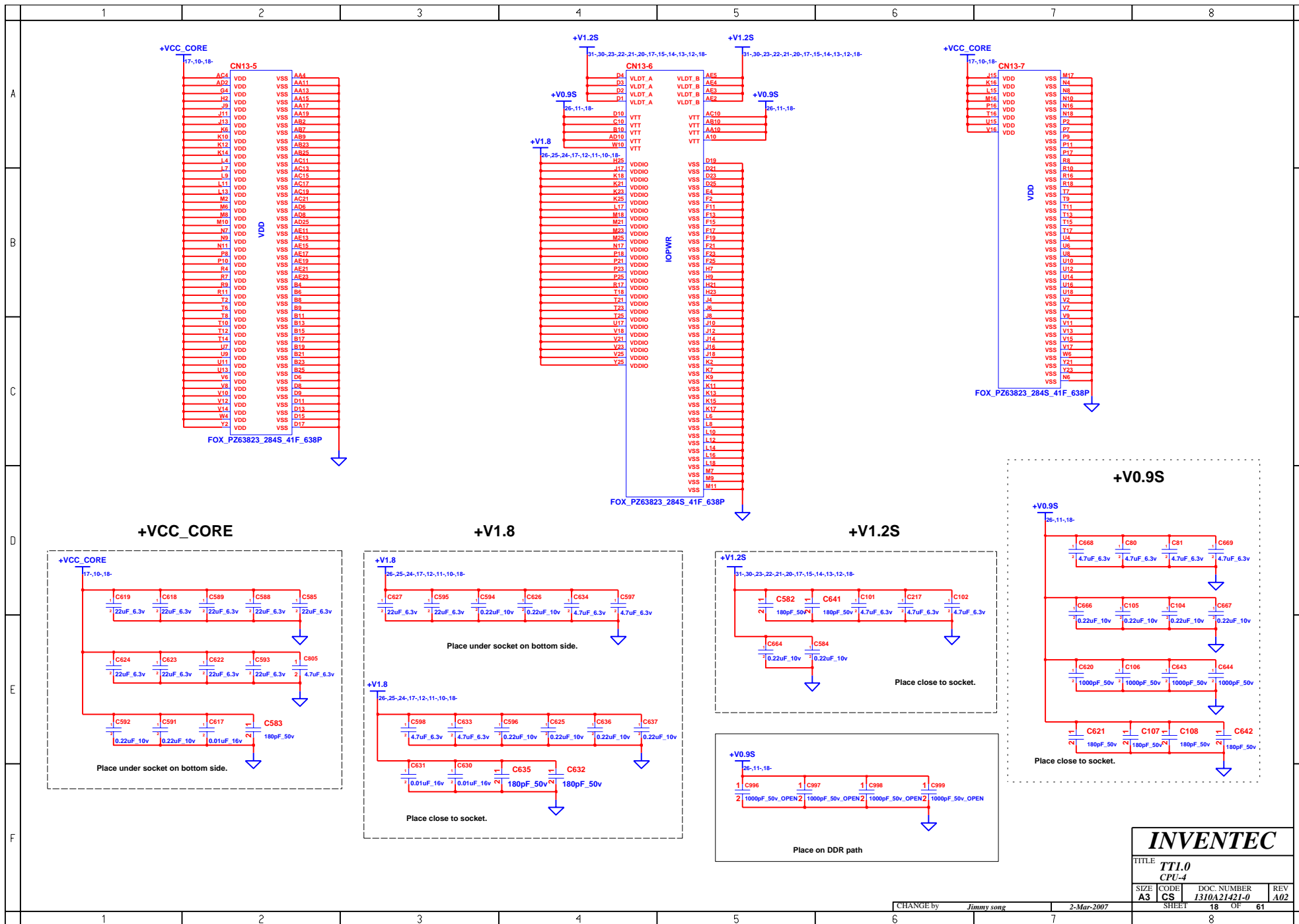

<b>INVENTEC</b>			
TITLE <b>TTL0</b> <b>CPU-4</b>			
SIZE <b>A3</b>	CODE <b>CS</b>	DOC. NUMBER <b>1310A21421-0</b>	REV <b>A02</b>
CHANGE by <i>Jimmy song</i>		2-Mar-2007	
SHEET <b>18</b>		OF <b>61</b>	



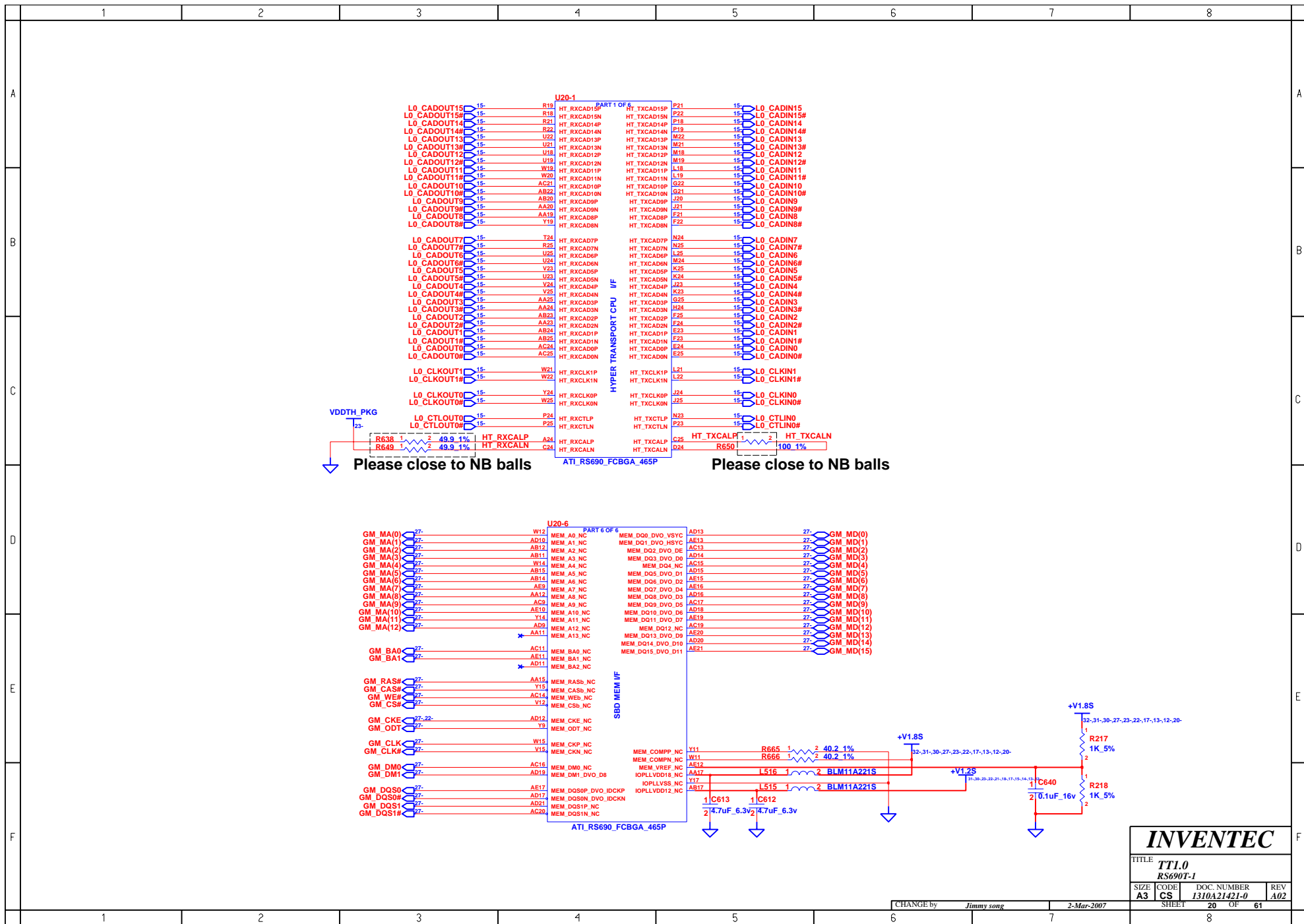

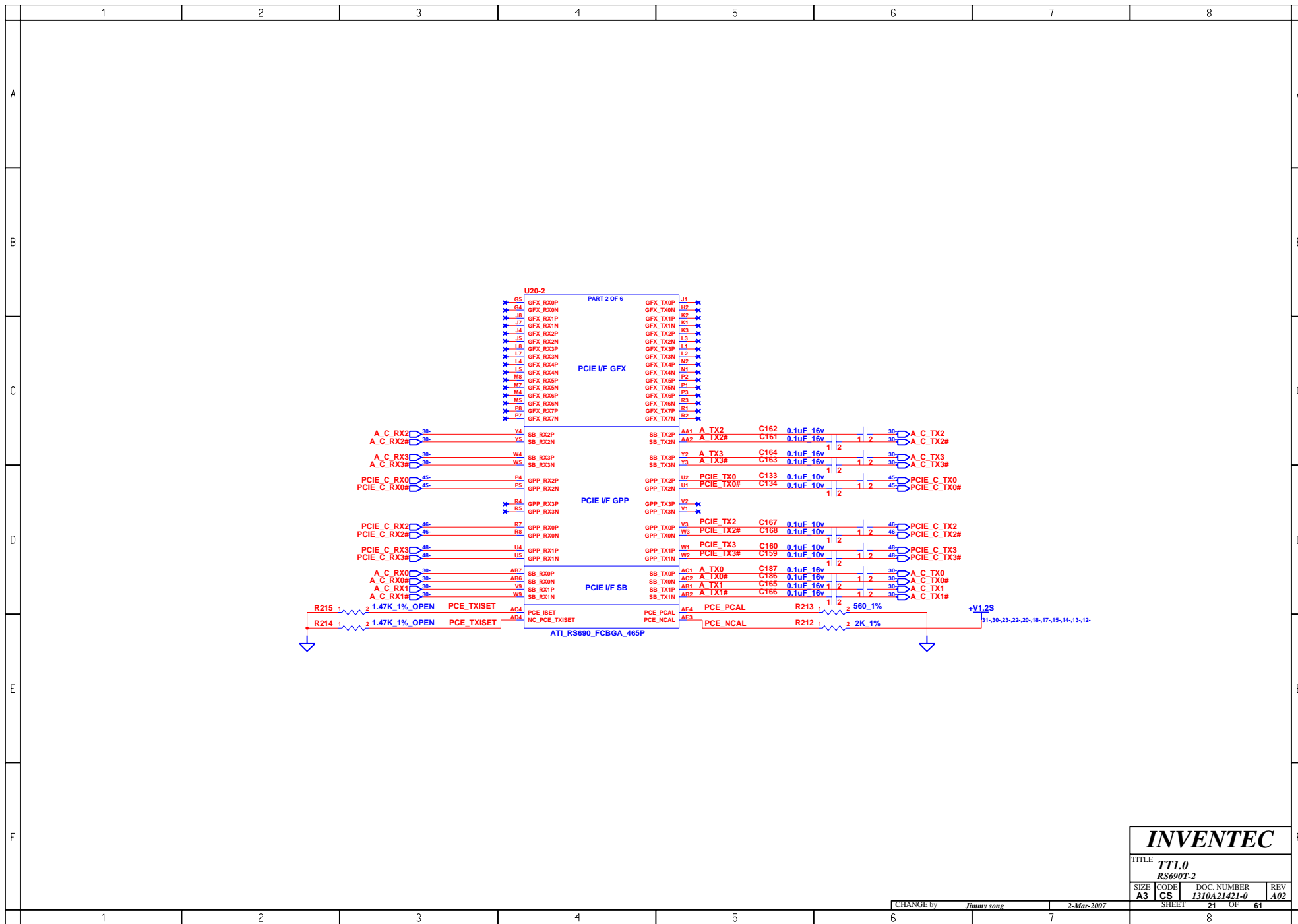

<b>INVENTEC</b>			
TITLE <b>TTL0</b> <b>RS690T-2</b>			
SIZE <b>A3</b>	CODE <b>CS</b>	DOC. NUMBER <b>1310A21421-0</b>	REV <b>A02</b>
CHANGE by <i>Jimmy song</i>		2-Mar-2007	
SHEET 21		OF 61	

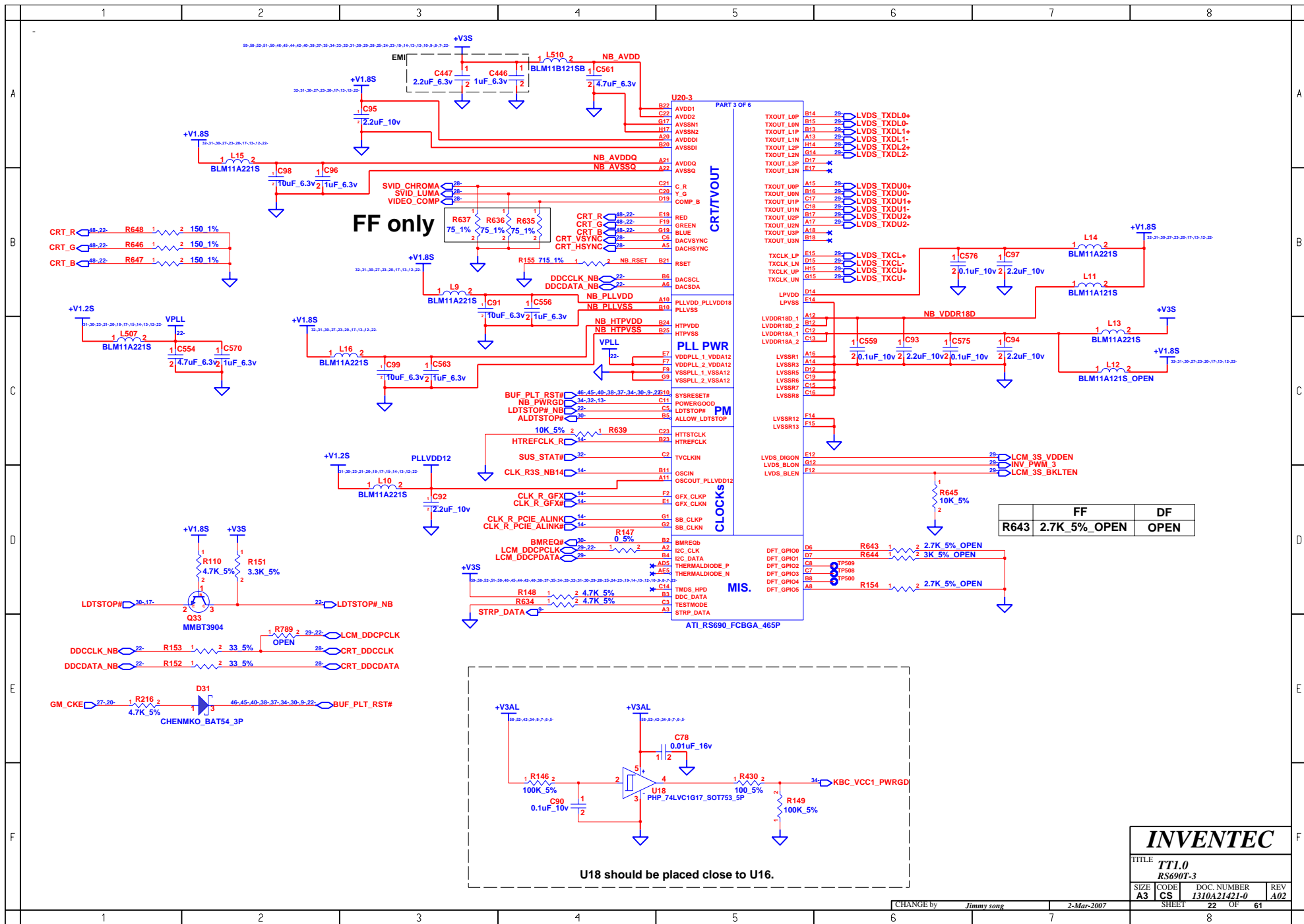

	FF	DF
R643	2.7K 5% OPEN	OPEN

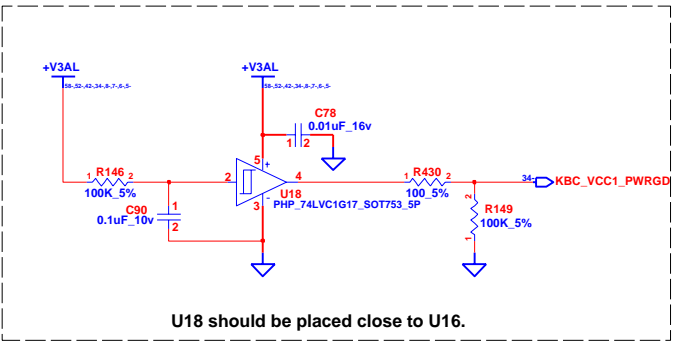

U18 should be placed close to U16.

**INVENTEC**

TITLE  
TT1.0  
RS690T-3

SIZE A3	CODE CS	DOC. NUMBER I310A21421-0	REV A02
------------	------------	-----------------------------	------------

SHEET 22 OF 61



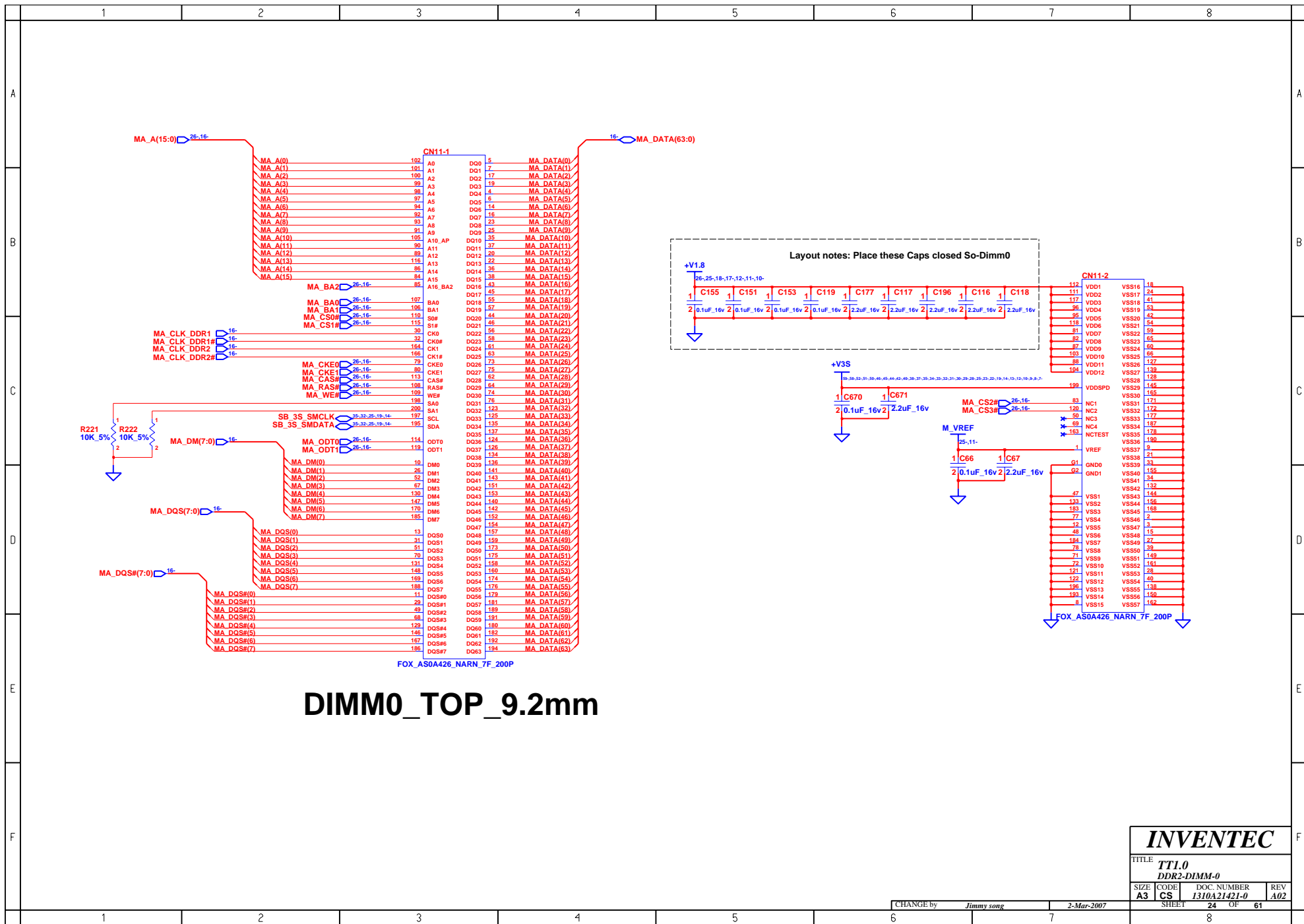

**INVENTEC**

TITLE TTI.0			
DDR2-DIMM-0			
SIZE A3	CODE CS	DOC. NUMBER 1310A21421-0	REV A02
CHANGE by Jimmy song		2-Mar-2007	SHEET 24 OF 61

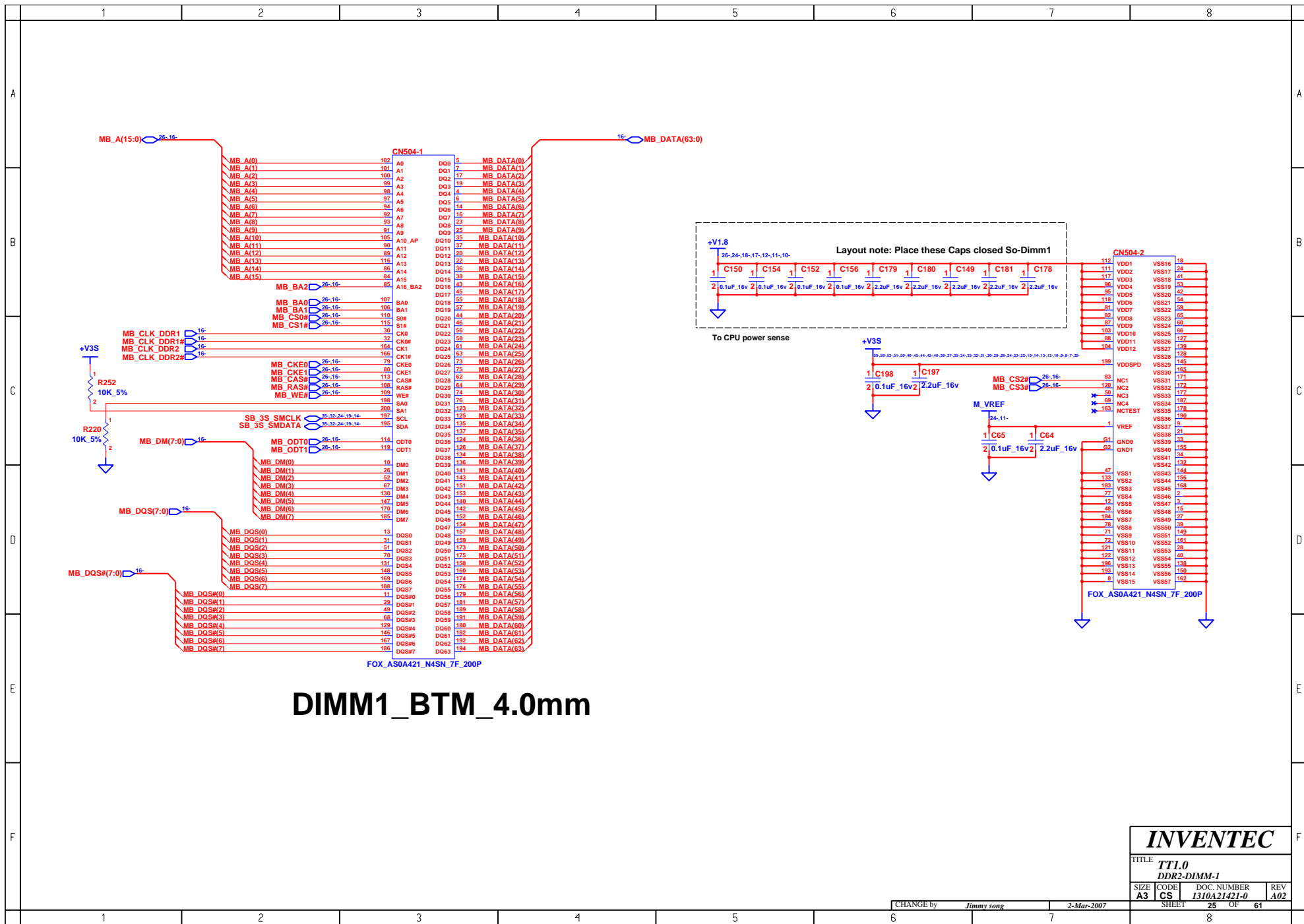

<b>INVENTEC</b>			
TITLE TTI.0			
DDR2-DIMM-1			
SIZE A3	CODE CS	DOC. NUMBER 1310A21421-0	REV A02
CHANGE by Jimmy song		2-Mar-2007	
SHEET 25		OF 61	

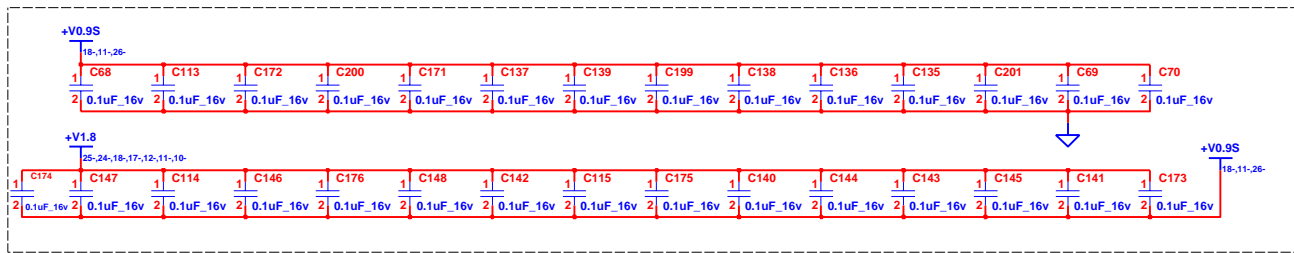

To CPU power sense

### Place CAPs close to DIMM

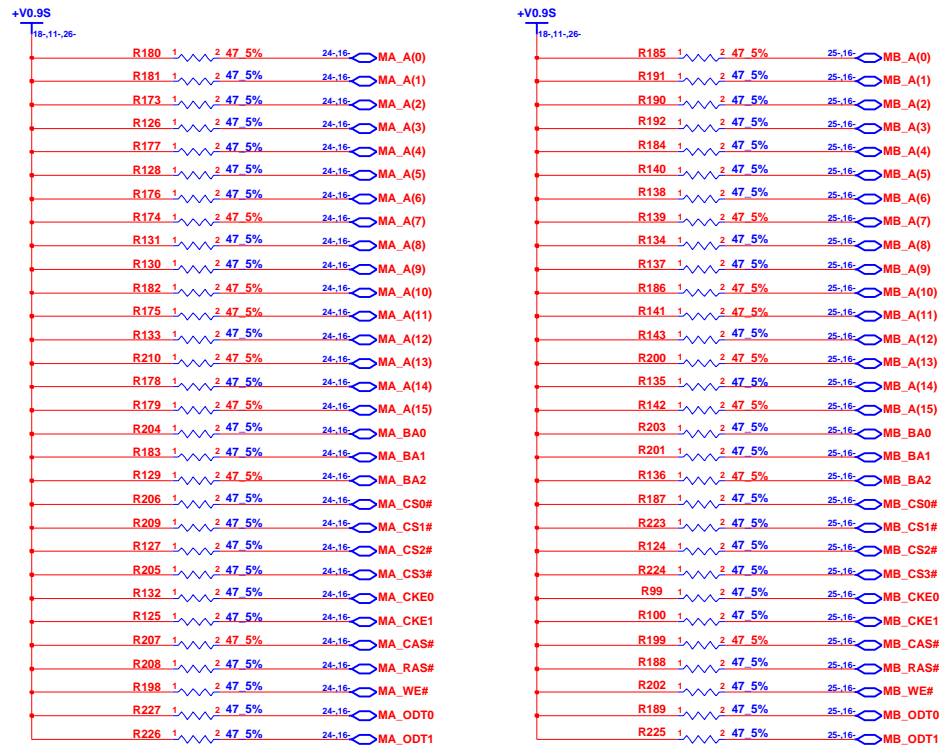

## INVENTEC

TITLE			
TTL0			
DDR2-DAMPING			
SIZE	CODE	DOC. NUMBER	REV
A3	CS	I310A21421-0	A02
CHANGE by		SHEET	OF
Jimmy song		26	61

2-Mar-2007

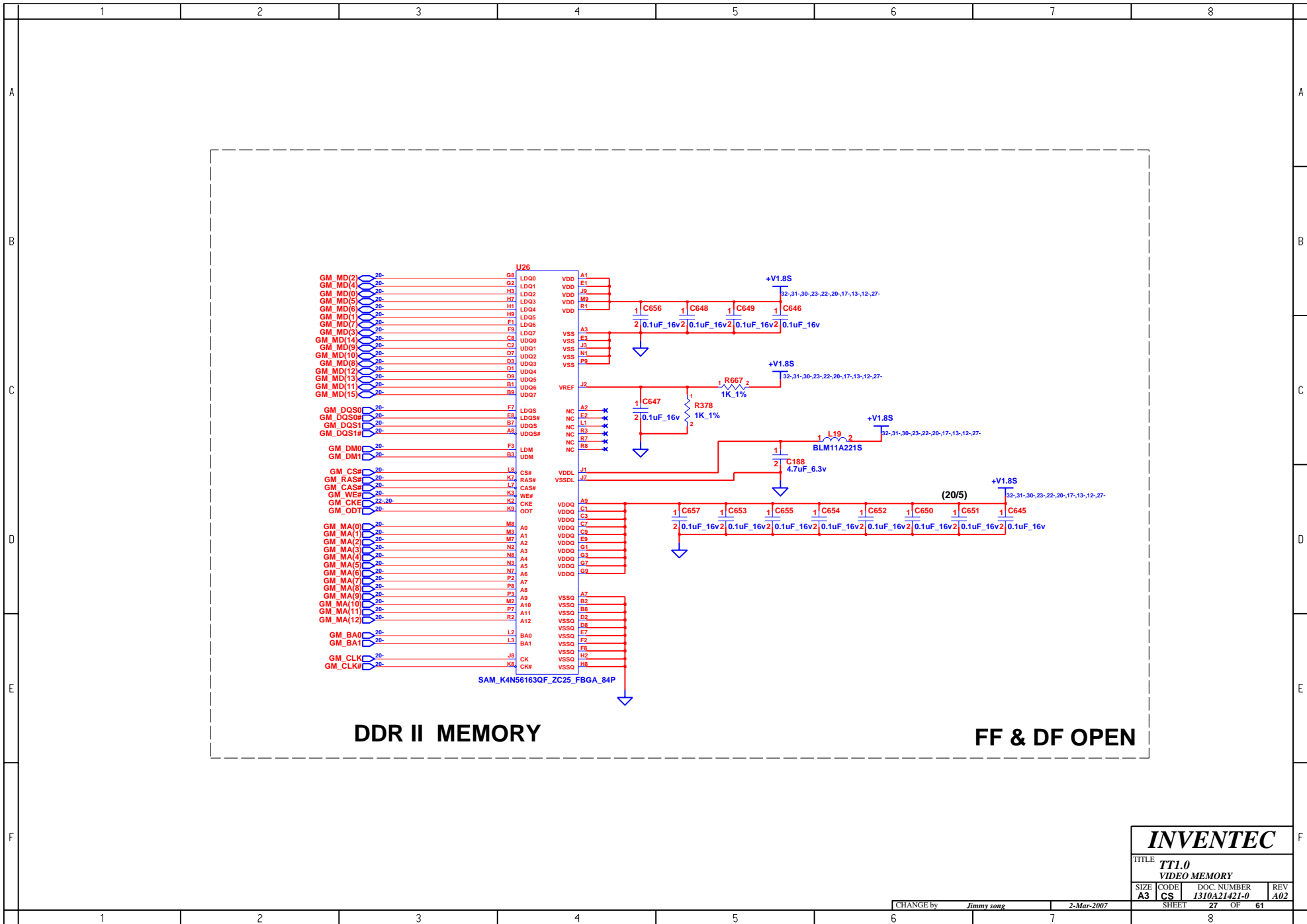

<b>INVENTEC</b>			
TITLE <b>TT1.0</b>			
VIDEO MEMORY			
SIZE	CODE	DOC NUMBER	REV
A3	CS	1310A21421-0	A02
CHANGE by		2-Mar-2007	
SHEET		27 OF 61	

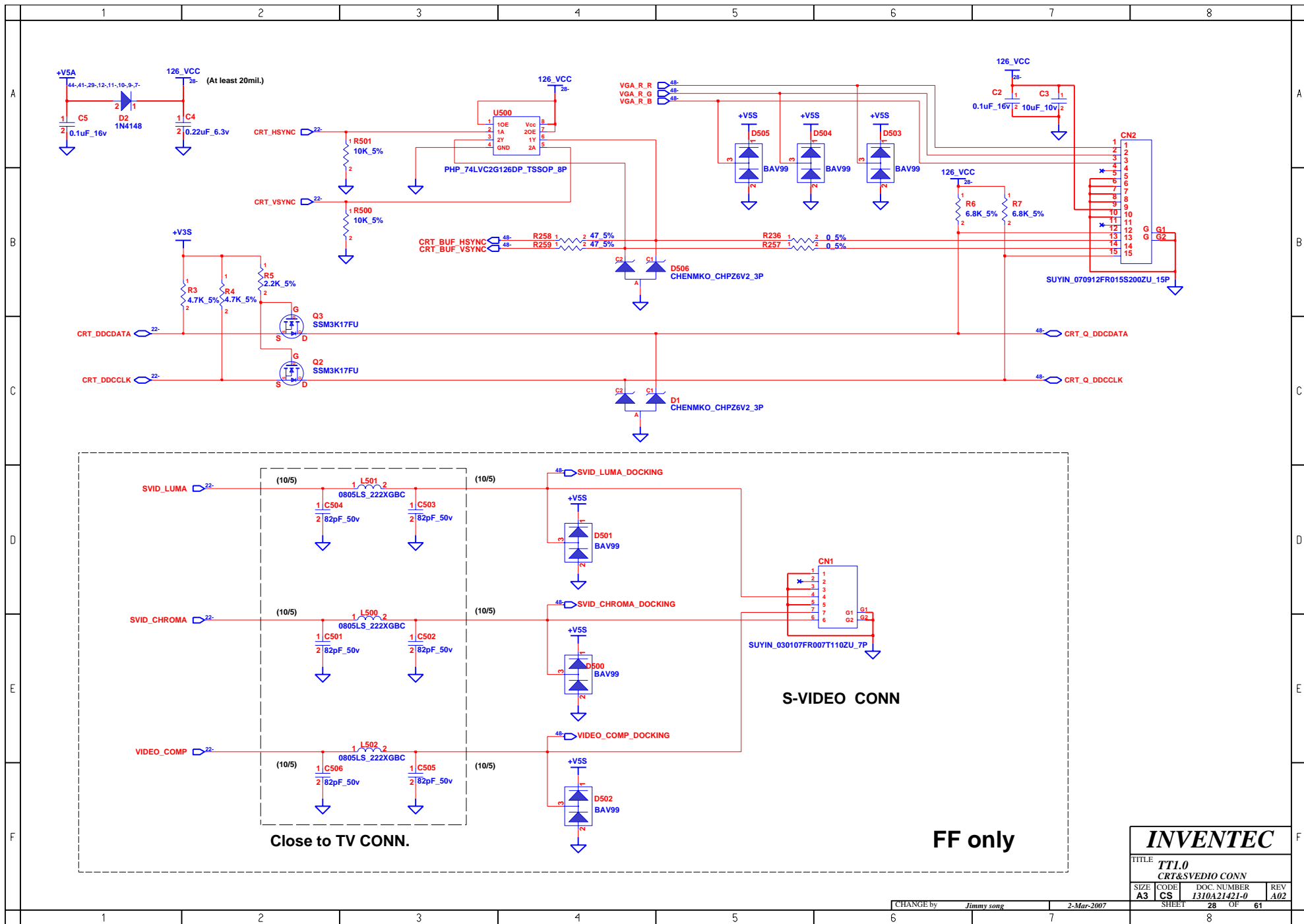

**INVENTEC**

TITLE			
TT1.0			
CRT&SVEDIO CONN			
SIZE	CODE	DOC. NUMBER	REV
A3	CS	1310A21421-0	A02

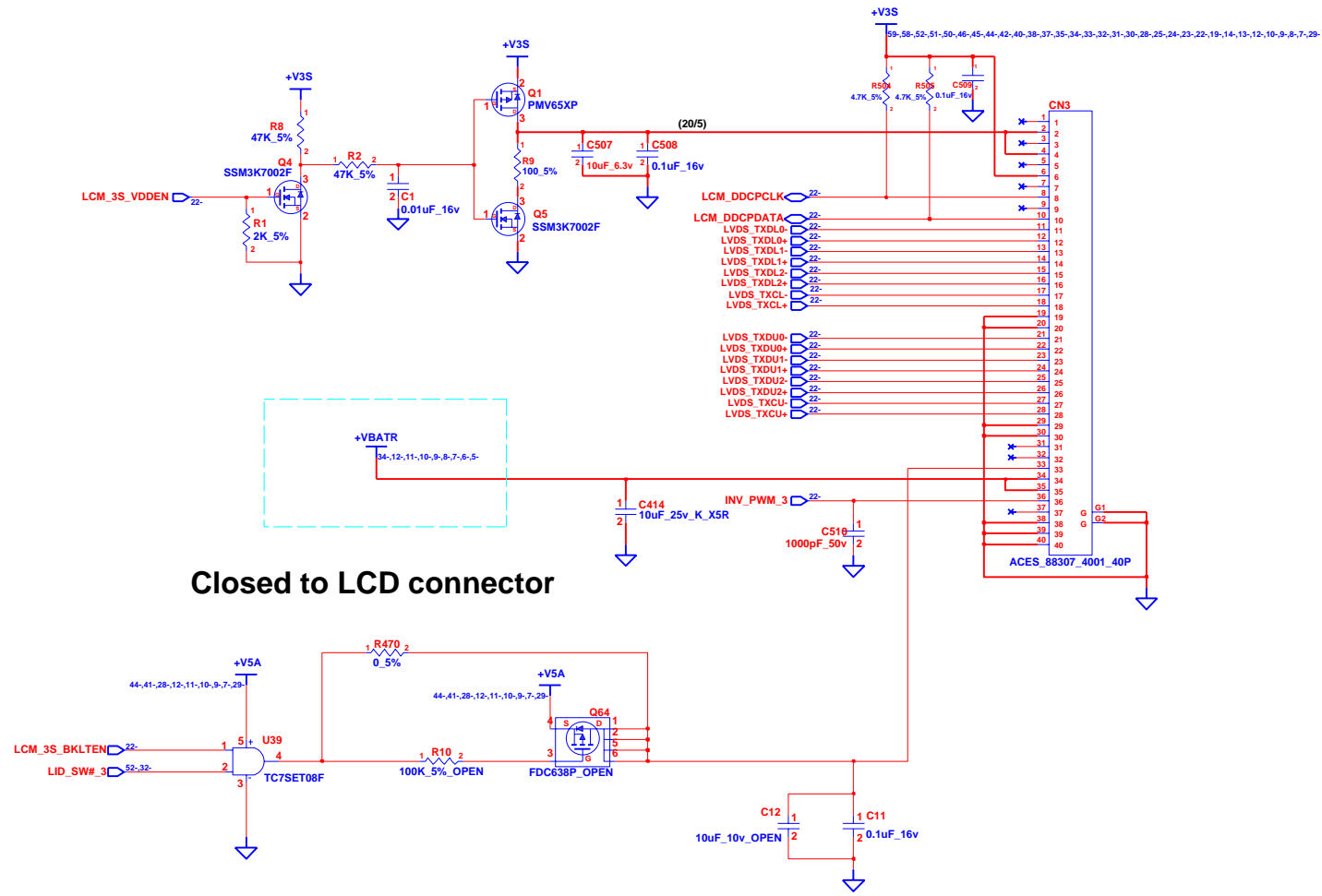

Closed to LCD connector

**INVENTEC**

TITLE			
TTL0			
LCD CONN			
SIZE	CODE	DOC. NUMBER	REV
A3	CS	1310A21421-0	A02



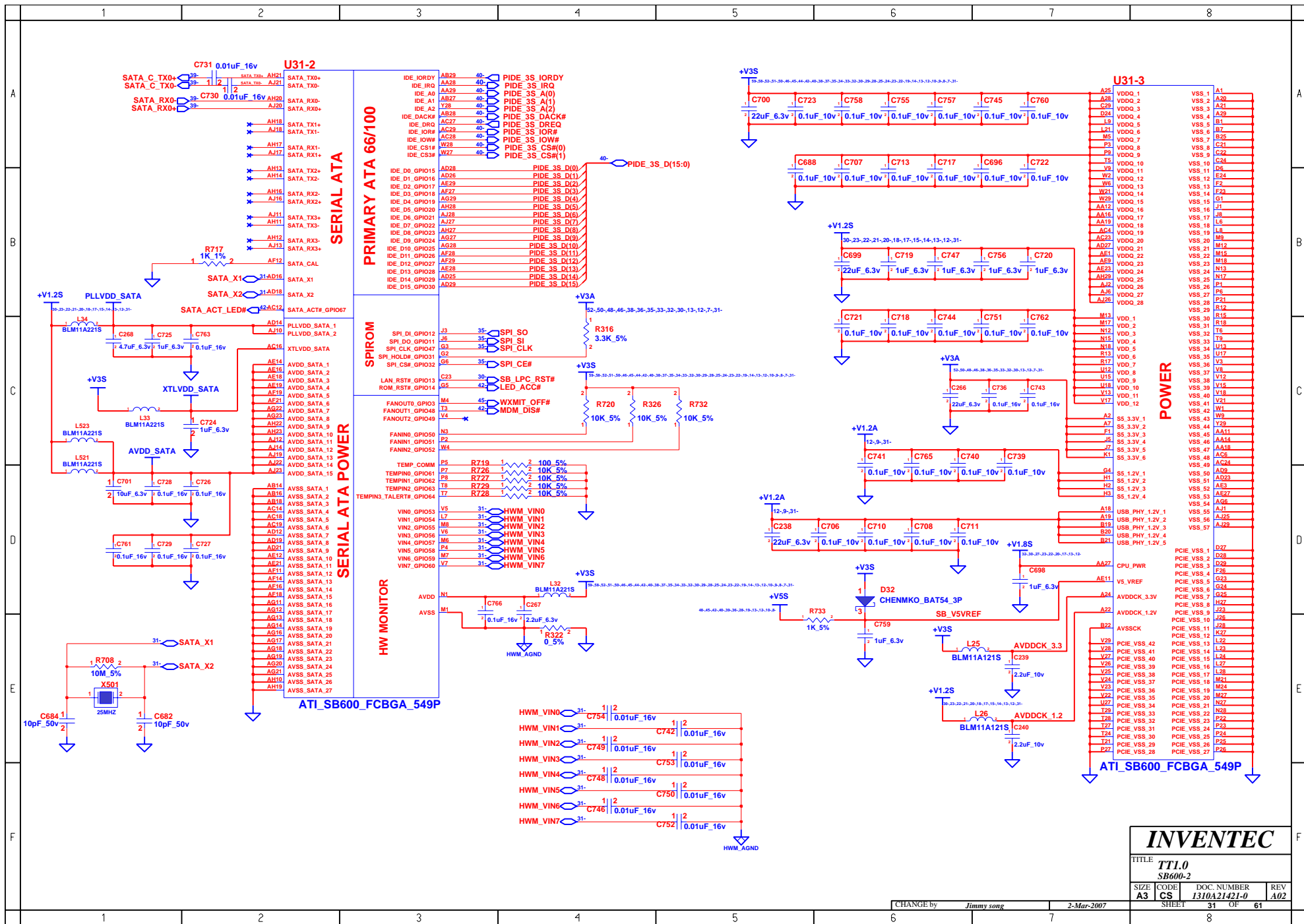

**INVENTEC**

TITLE  
**TT1.0  
SB600-2**

SIZE	CODE	DOC. NUMBER	REV
A3	CS	I310A21421-0	A02

CHANGE by Jimmy song 2-Mar-2007

SHEET 31 OF 61



**Required Straps:**

	AC_SDOUT	RTC_CLK	CLK_R3S_FWHPCI	PCI_CLK6	PCI_CLK0 PCI_CLK1
<b>PULL HIGH</b>	USE DEBUG STRAPS	INTERNAL RTC	USE INT. PLL48	CPU K8	HH: PCI ROM HL: SPI ROM
<b>PULL LOW</b>	IGNORE DEBUG STRAPS	EXTERNAL RTC	USE EXT. 48M CLK	CPU P4	LH: LPC ROM LL: FWH ROM

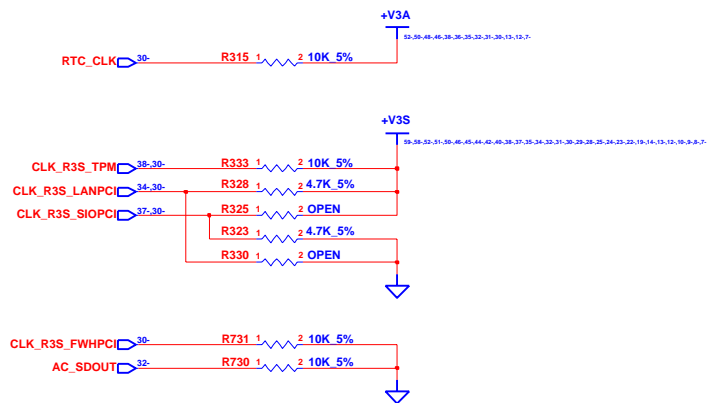

**INVENTEC**

TITLE *TT1.0*  
SB600-4

SIZE	CODE	DOC. NUMBER	REV
A3	CS	1310A21421-0	A02

CHANGE by *Jimmy song* 2-Mar-2007

SHEET 33 OF 61

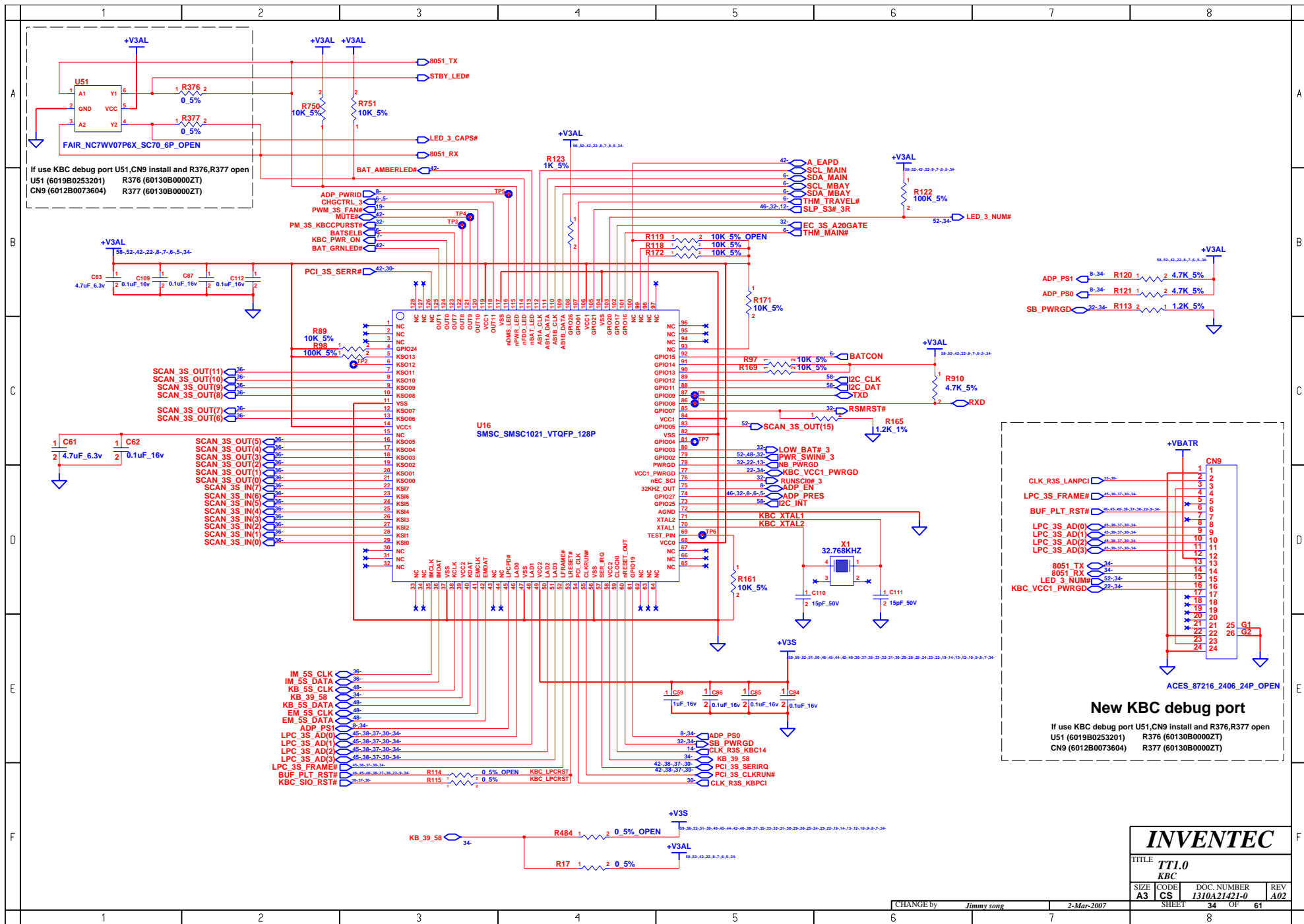

**New KBC debug port**

If use KBC debug port U51, C99 install and R376, R377 open  
 U51 (6019B0253201) R376 (60130B0000ZT)  
 C99 (6012B0073604) R377 (60130B0000ZT)

<b>INVENTEC</b>			
TITLE <b>TTI.0 KBC</b>			
SIZE <b>A3</b>	CODE <b>CS</b>	DOC. NUMBER <b>1310A21421-0</b>	REV <b>A02</b>
CHANGE by <i>Jimmy song</i>		2-Mar-2007	
SHEET <b>34</b>		OF <b>61</b>	

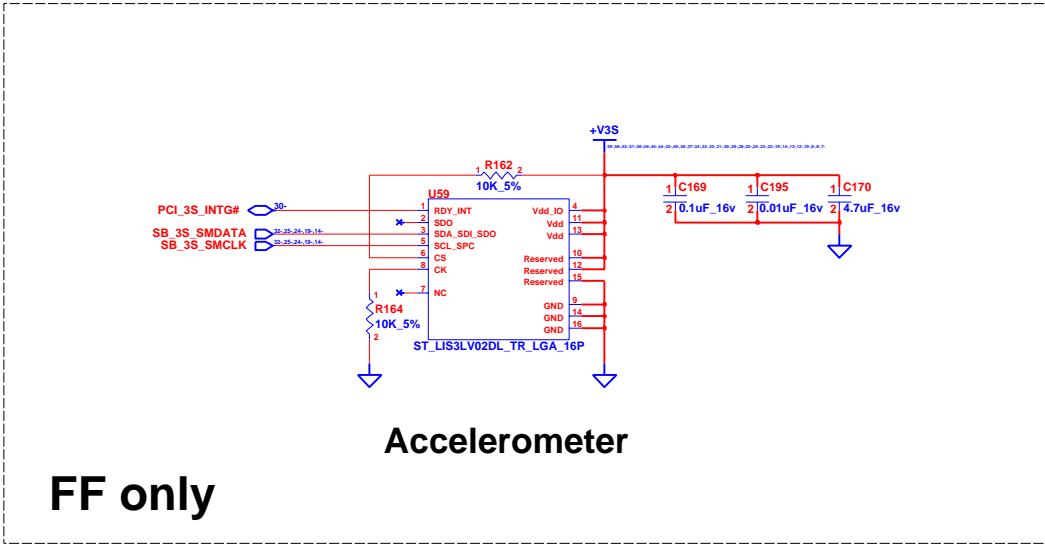
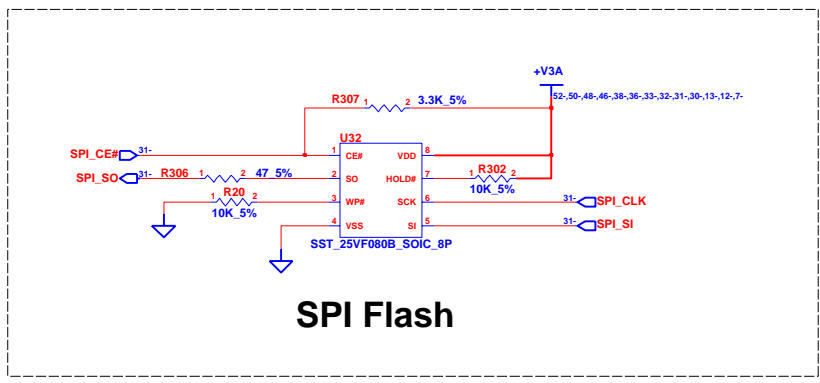

**INVENTEC**

TITLE			
TT1.0			
SPI & Accelerometer			
SIZE	CODE	DOC. NUMBER	REV
A3	CS	1310A21421-0	A02

CHANGE by Jimmy song 2-Mar-2007

SHEET 35 OF 61

### Keyboard CONN

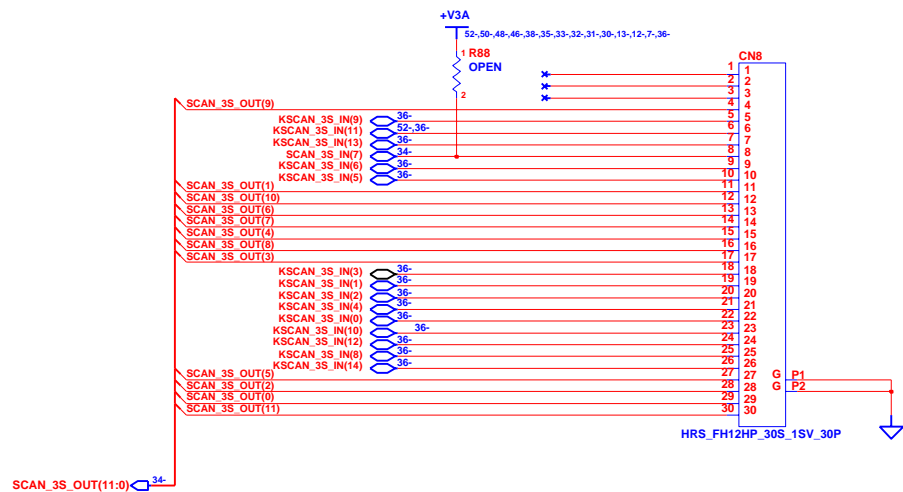

### Touch Pad CONN

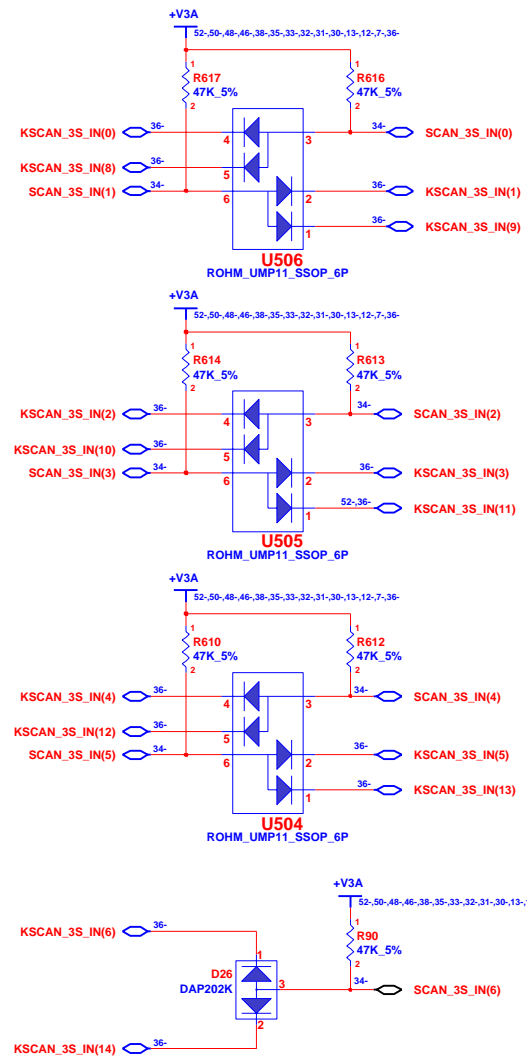
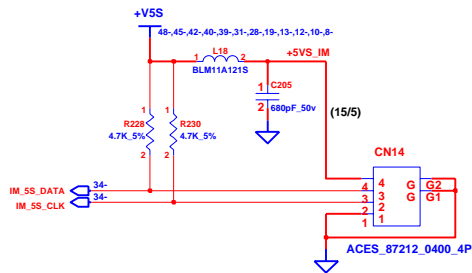

**INVENTEC**

TITLE  
TTL0  
INT.KBC/POINT DEVICES

SIZE CODE DOC NUMBER REV  
A3 CS 1310A21421-0 A02

CHANGE by Jimmy song 2-Mar-2007

SHEET 36 OF 61

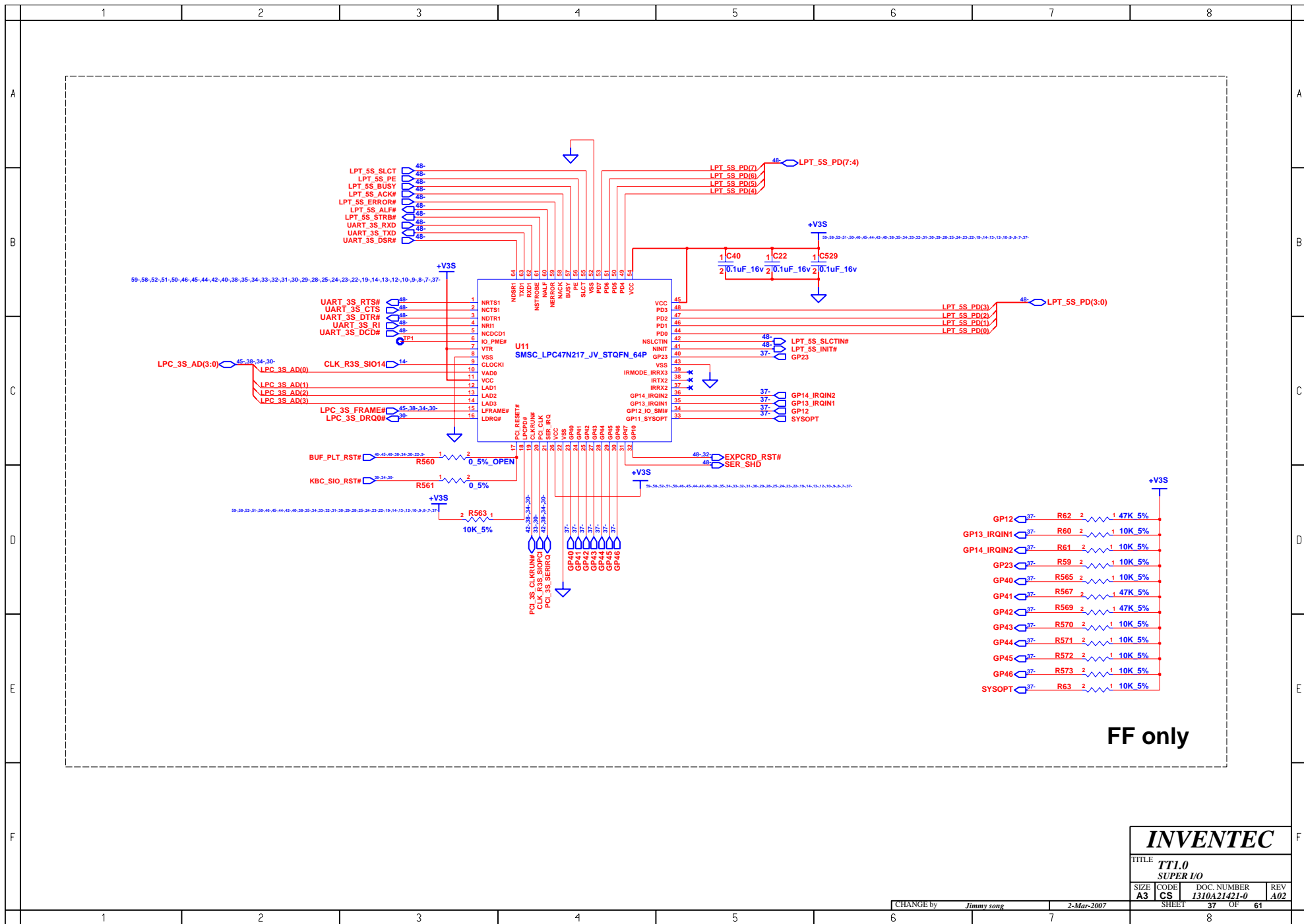

FF only

<b>INVENTEC</b>			
TITLE <b>TT1.0 SUPER I/O</b>			
SIZE <b>A3</b>	CODE <b>CS</b>	DOC. NUMBER <b>1310A21421-0</b>	REV <b>A02</b>
CHANGE by <i>Jimmy song</i>		2-Mar-2007	
SHEET <b>37</b>		OF <b>61</b>	

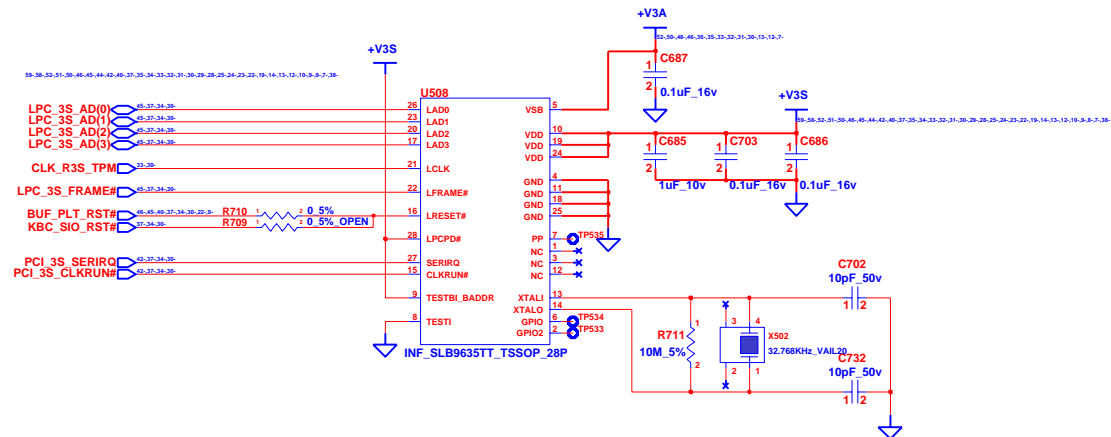

FF only

**INVENTEC**

TITLE			
TTL0			
TPM V1.2			
SIZE	CODE	DOC. NUMBER	REV
A3	CS	1310A21421-0	A02

CHANGE by Jimmy song 2-Mar-2007

SHEET 38 OF 61

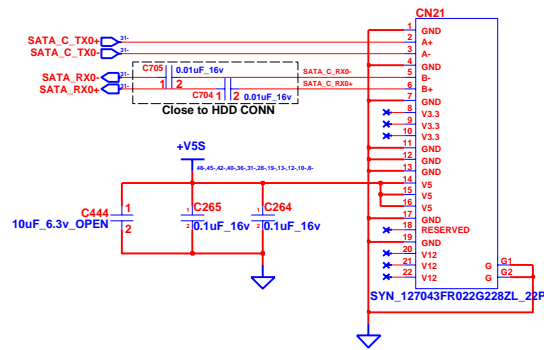

# HDD CONN

**INVENTEC**

TITLE			
TTL.0			
SATA HDD CONN			
SIZE	CODE	DOC. NUMBER	REV
A3	CS	1310A21421-0	A02

CHANGE by Jimmy song 2-Mar-2007

SHEET 39 OF 61

1	2	3	4	5	6	7	8
A							
B							
C							
D							
E							
F							
1	2	3	4	5	6	7	8

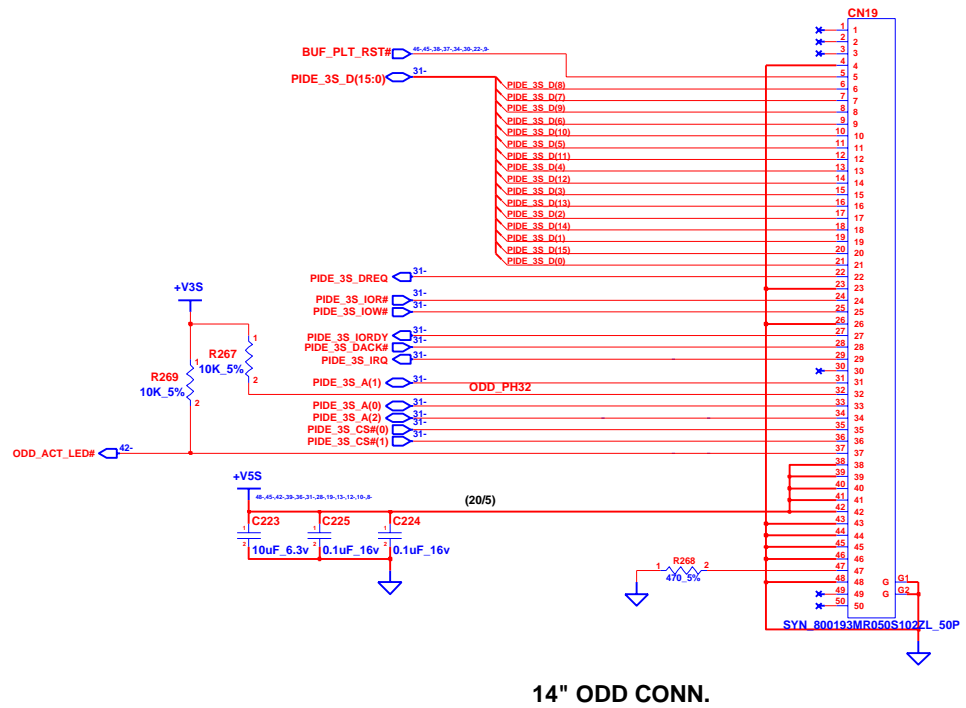

14" ODD CONN.

<b>INVENTEC</b>			
TITLE <i>TTL0</i> <i>Fixed ODD</i>			
SIZE	CODE	DOC. NUMBER	REV
A3	CS	1310A21421-0	A02
CHANGE by		SHEET	OF
Jimmy song		40	61

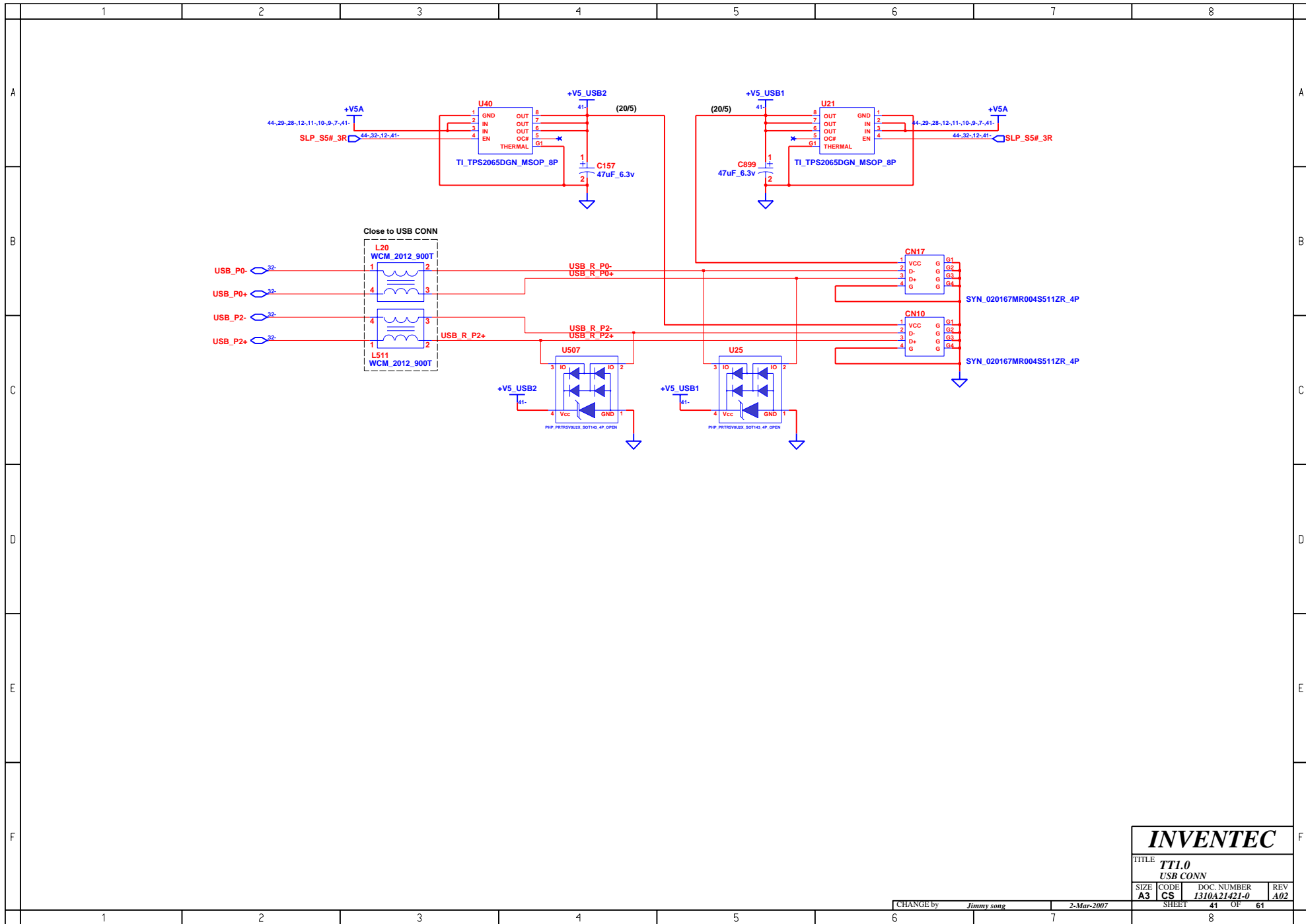

**INVENTEC**

TITLE			
TTL.0			
USB CONN			
SIZE	CODE	DOC. NUMBER	REV
A3	CS	1310A21421-0	A02

CHANGE by	Jimmy song	2-Mar-2007	SHEET	41	OF	61
-----------	------------	------------	-------	----	----	----

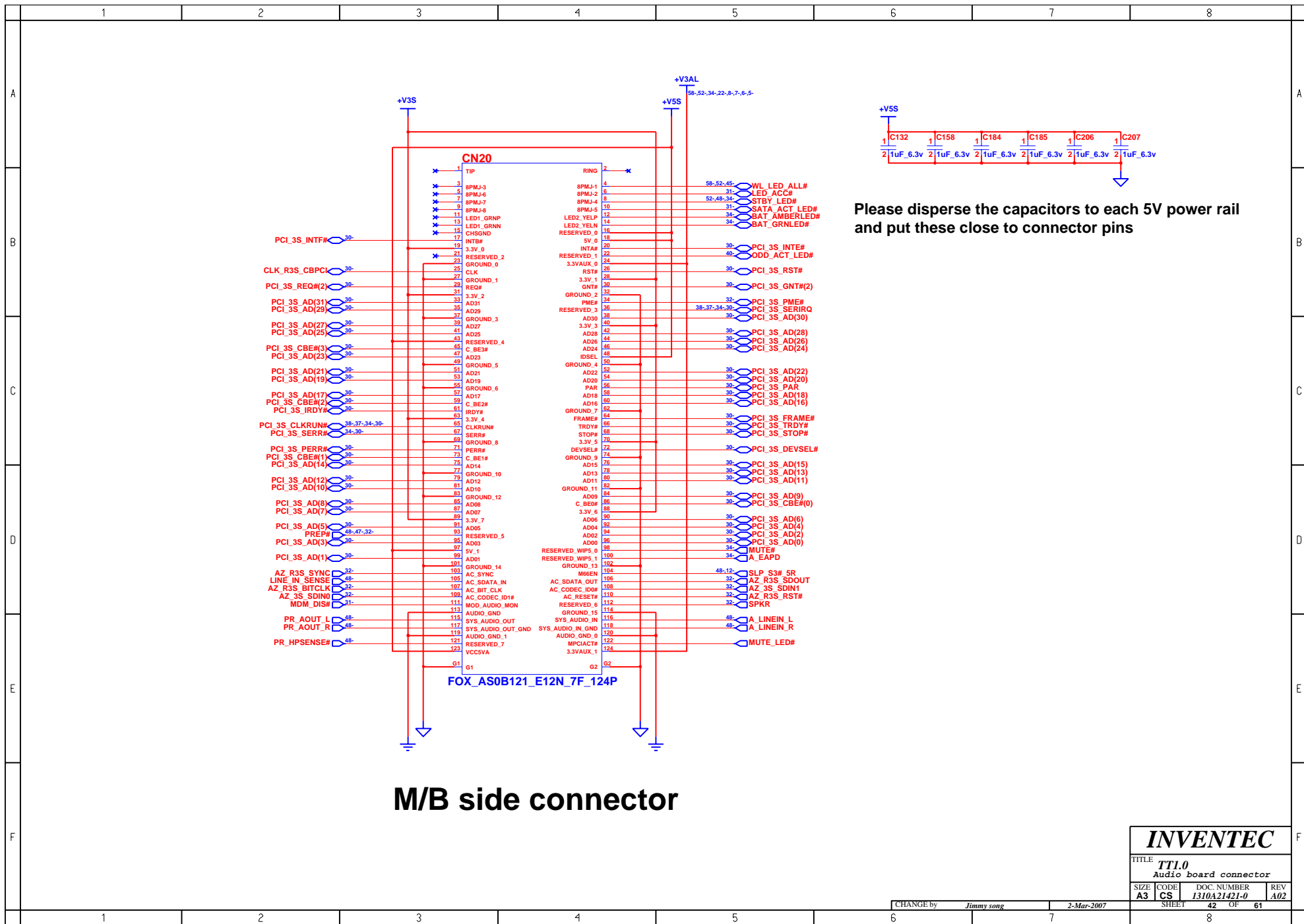

<b>INVENTEC</b>			
TITLE <b>TT1.0</b>			
Audio board connector			
SIZE <b>A3</b>	CODE <b>CS</b>	DOC. NUMBER <b>1310A21421-0</b>	REV <b>A02</b>
CHANGE by <i>Jimmy song</i>		2-Mar-2007	
SHEET 42		OF 61	

**BLANK**

<b>INVENTEC</b>			
TITLE <i>TT1.0</i> <i>BLANK</i>			
SIZE <b>A3</b>	CODE <b>CS</b>	DOC. NUMBER <i>1310A21421-0</i>	REV <i>A02</i>
CHANGE by <i>Jimmy song</i>		2-Mar-2007	
SHEET		43	OF 61

	1	2	3	4	5	6	7	8	
A									A
B									B
C									C
D									D
E									E
F									F
	1	2	3	4	5	6	7	8	

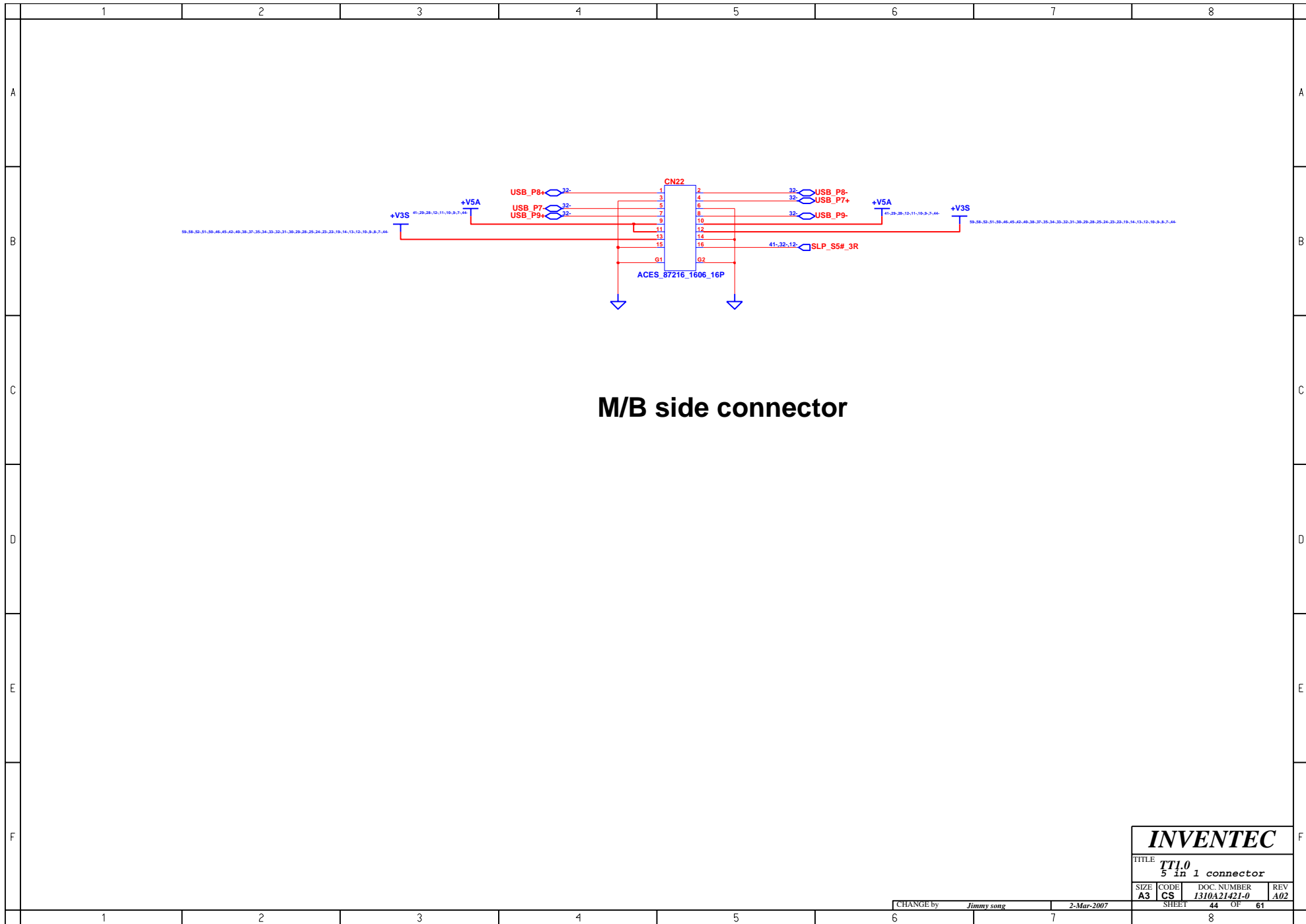

<b>INVENTEC</b>			
TITLE <b>TT1.0</b>			
5 in 1 connector			
SIZE	CODE	DOC. NUMBER	REV
A3	CS	1310A21421-0	A02

CHANGE by *Jimmy song* 2-Mar-2007

SHEET 44 OF 61

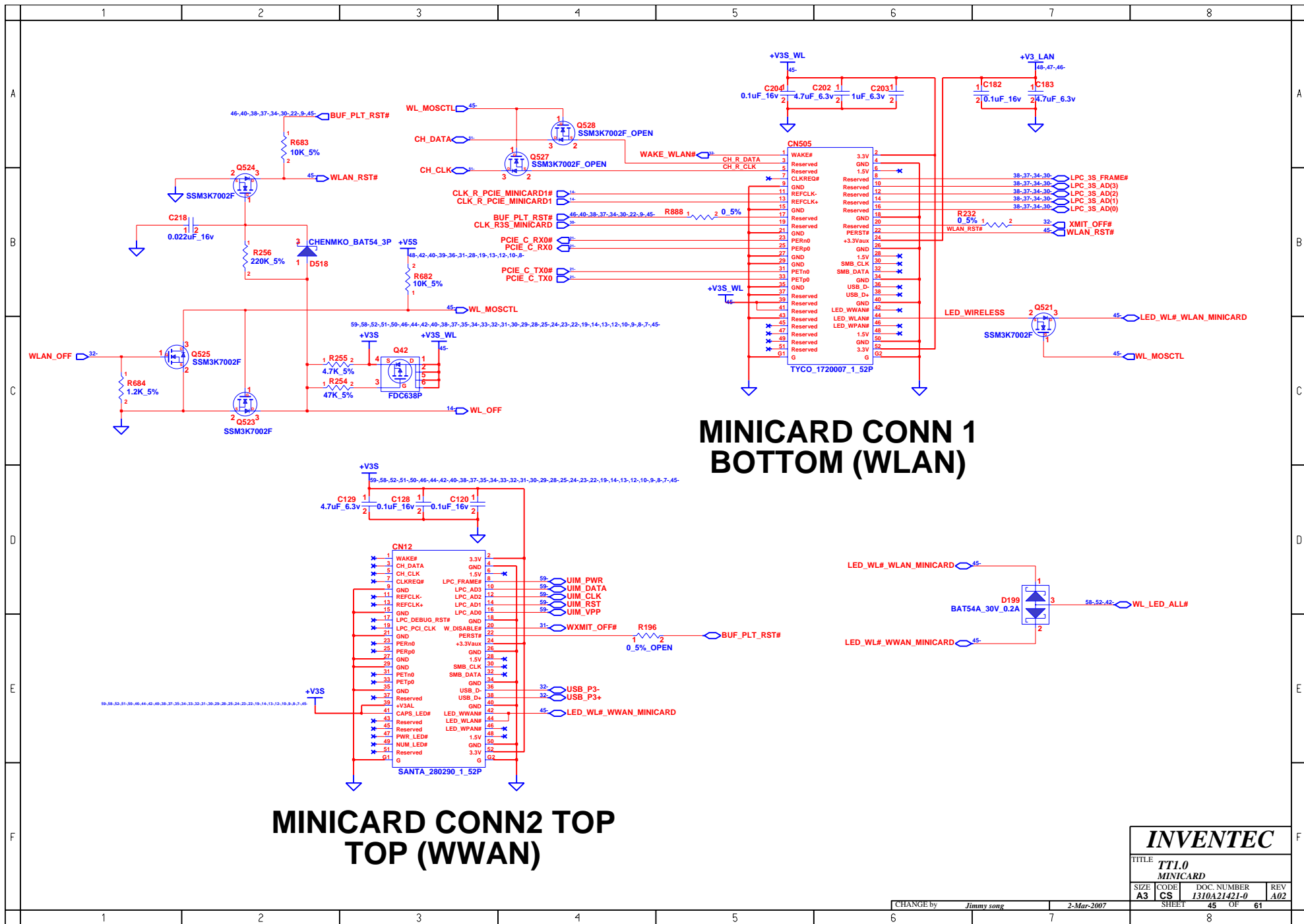

# MINICARD CONN 1 BOTTOM (WLAN)

# MINICARD CONN2 TOP TOP (WWAN)

**INVENTEC**

TITLE			
TTL0			
MINICARD			
SIZE	CODE	DOC. NUMBER	REV
A3	CS	1310A21421-0	A02

CHANGE by Jimmy song 2-Mar-2007

SHEET 45 OF 61

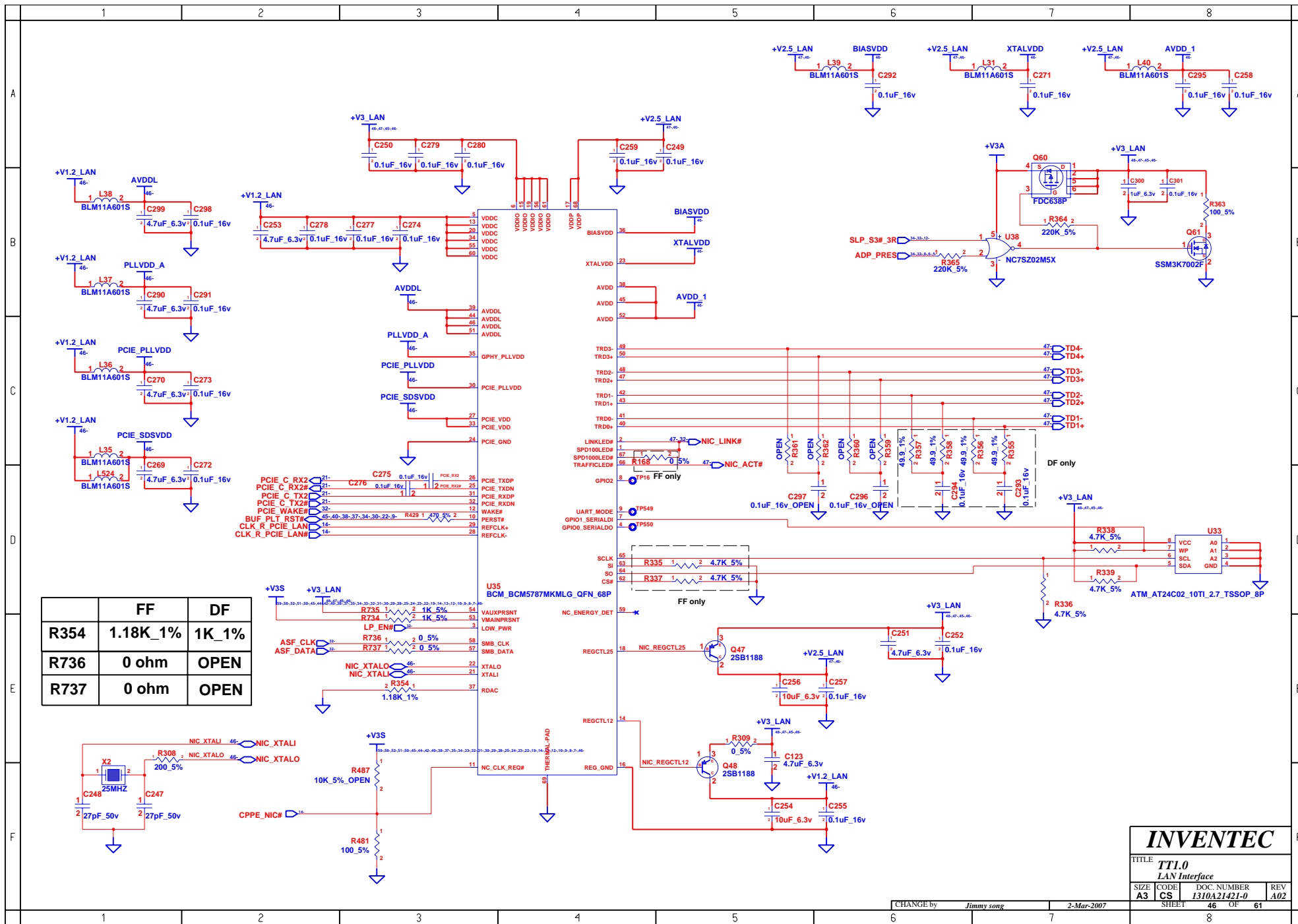

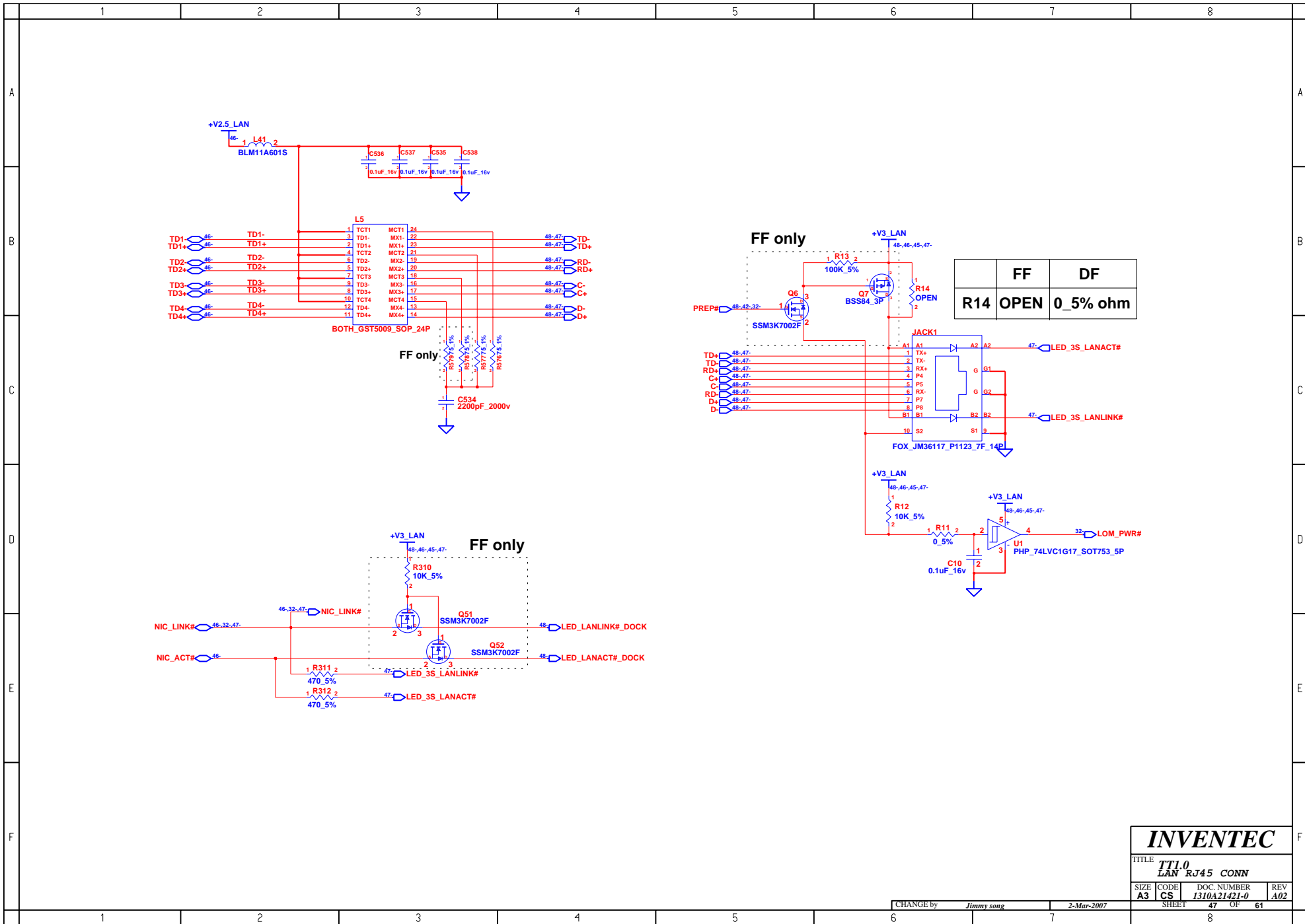

<b>INVENTEC</b>			
TITLE <i>TTL0</i> <i>LAN RJ45 CONN</i>			
SIZE <b>A3</b>	CODE <b>CS</b>	DOC. NUMBER <i>1310A21421-0</i>	REV <b>A02</b>
CHANGE by <i>Jimmy song</i>		2-Mar-2007	SHEET 47 OF 61

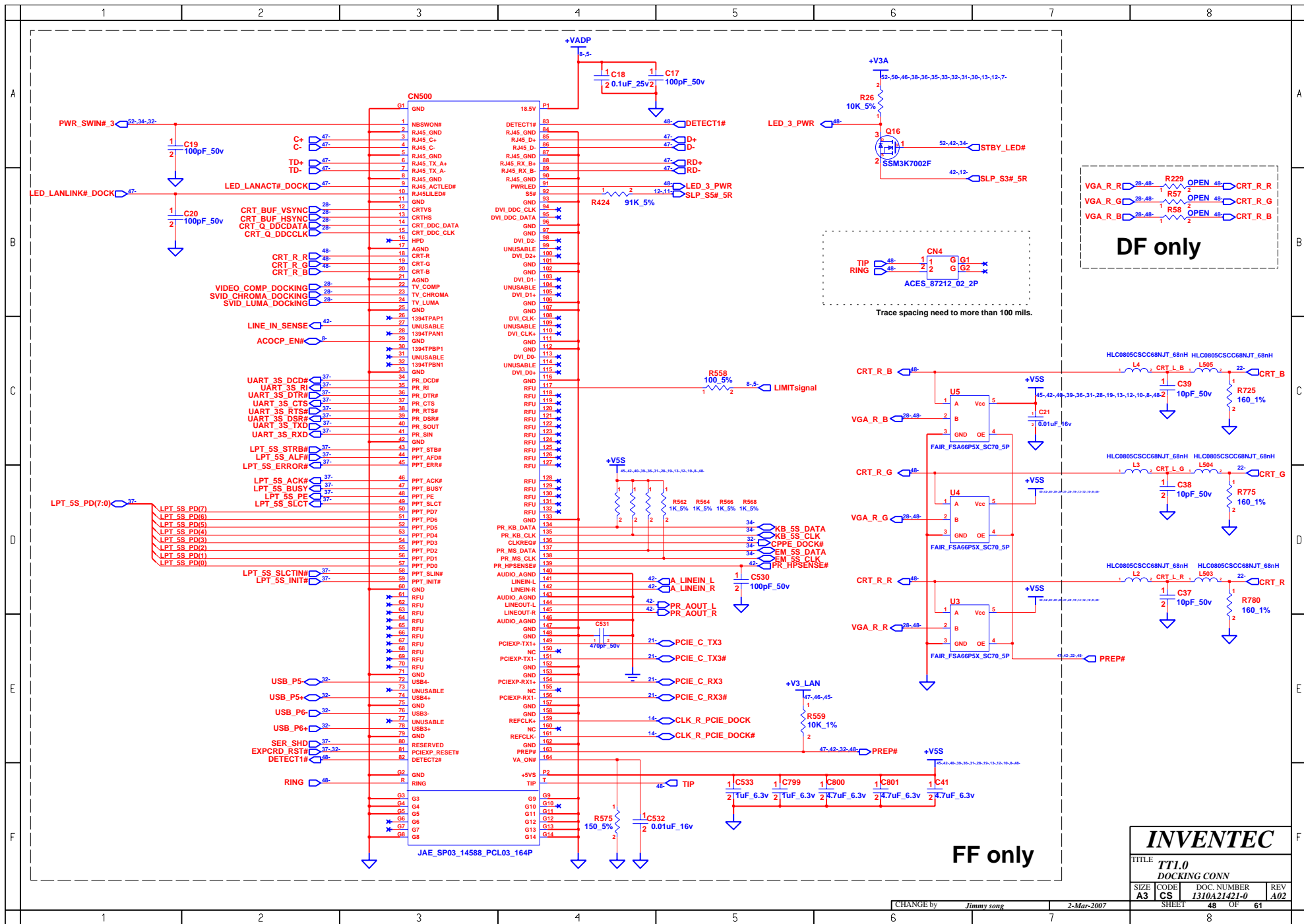

CHANGE by Jimmy song 2-Mar-2007

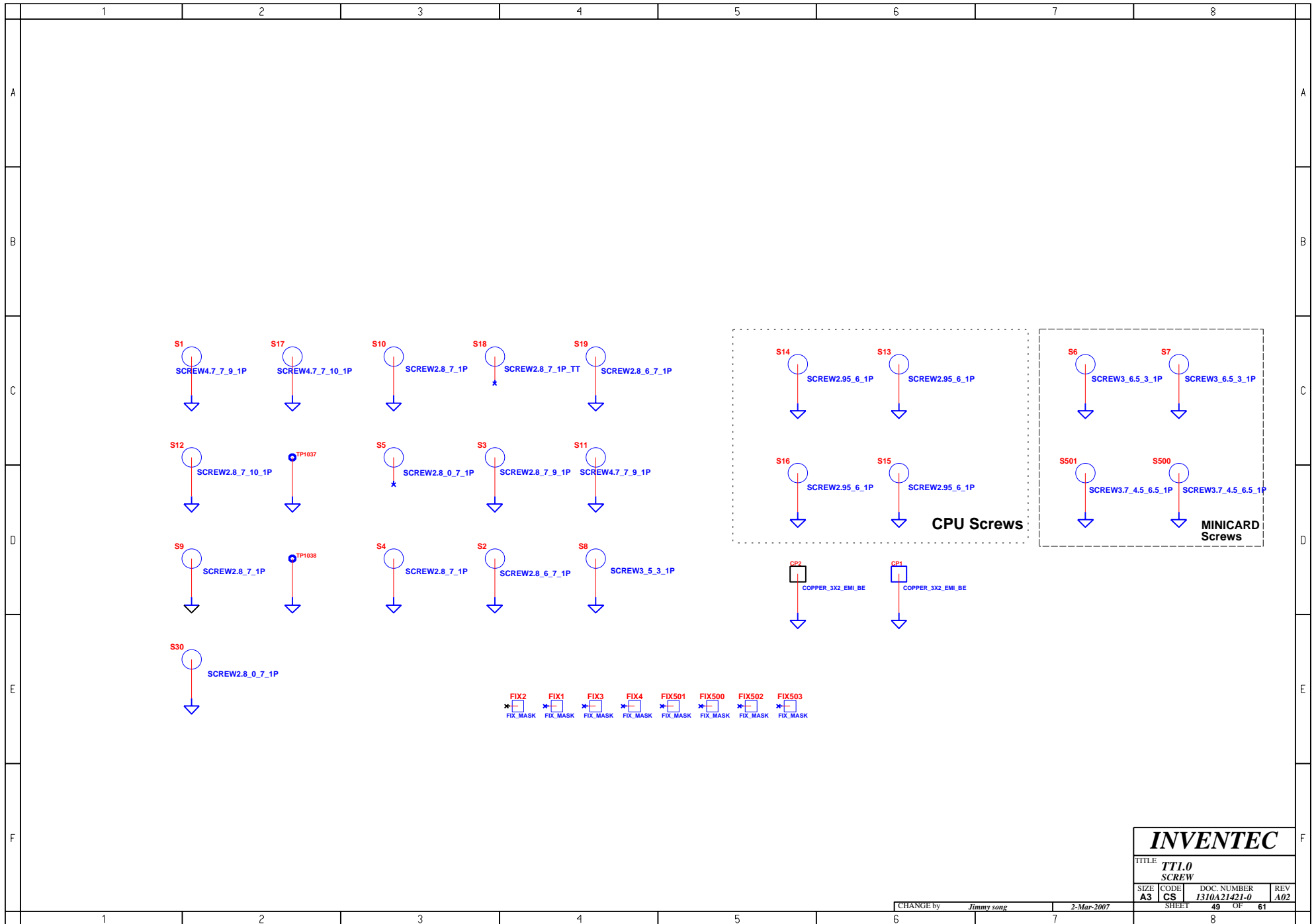

**INVENTEC**

TITLE			
TT1.0			
SCREW			
SIZE	CODE	DOC. NUMBER	REV
A3	CS	1310A21421-0	A02

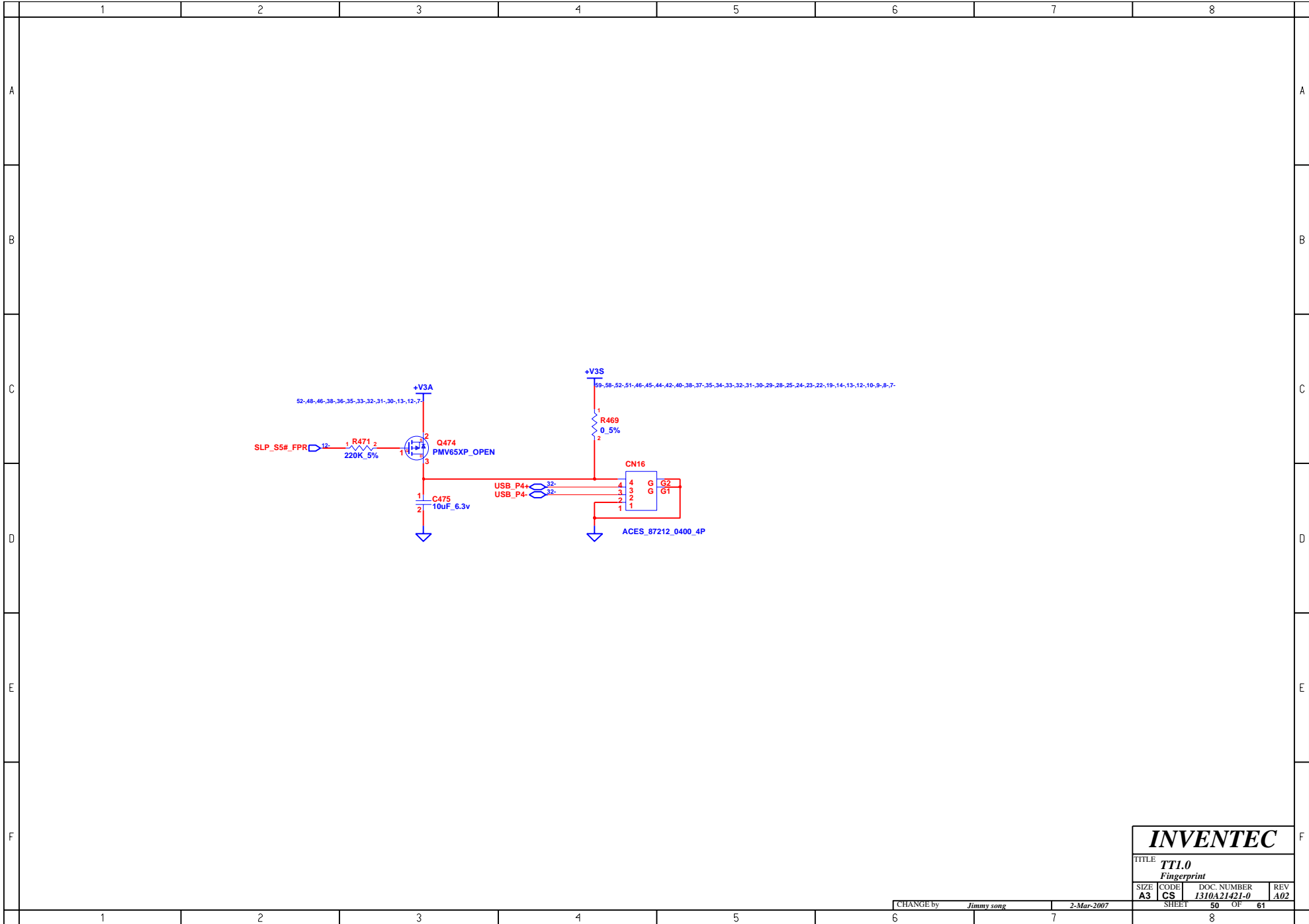

# INVENTEC

TITLE <b>TT1.0</b> Fingerprint			
SIZE <b>A3</b>	CODE <b>CS</b>	DOC. NUMBER <b>1310A21421-0</b>	REV <b>A02</b>
CHANGE by <i>Jimmy song</i>		2-Mar-2007	SHEET 50 OF 61

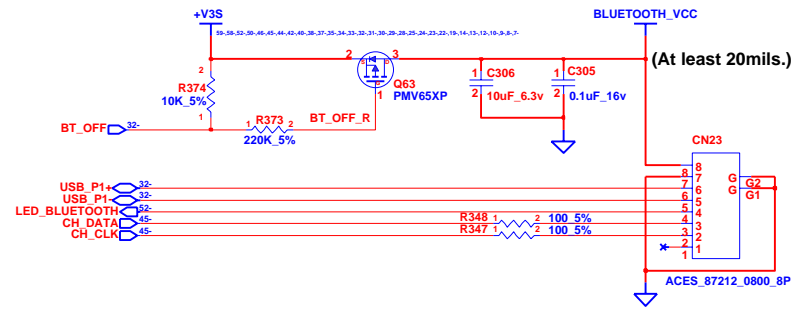

# INVENTEC

TITLE			
TT1.0			
BLUETOOTH			
SIZE	CODE	DOC. NUMBER	REV
A3	CS	1310A21421-0	A02
SHEET		51	OF 61

CHANGE by Jimmy song 2-Mar-2007

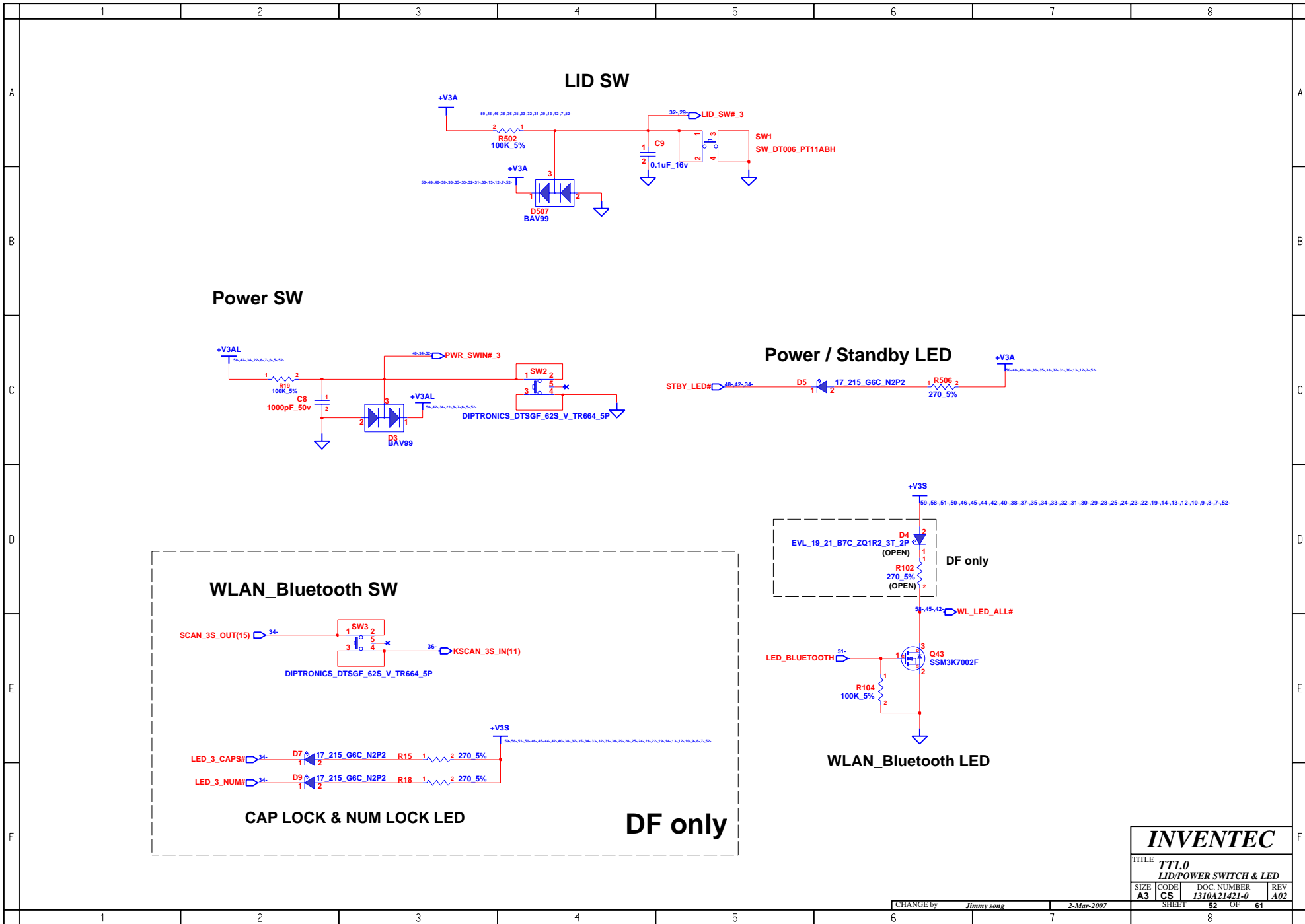

**INVENTEC**

TITLE			
TTL0			
LID/POWER SWITCH & LED			
SIZE	CODE	DOC. NUMBER	REV
A3	CS	1310A21421-0	A02

CHANGE by	Jimmy song	2-Mar-2007	SHEET	52	OF	61
-----------	------------	------------	-------	----	----	----

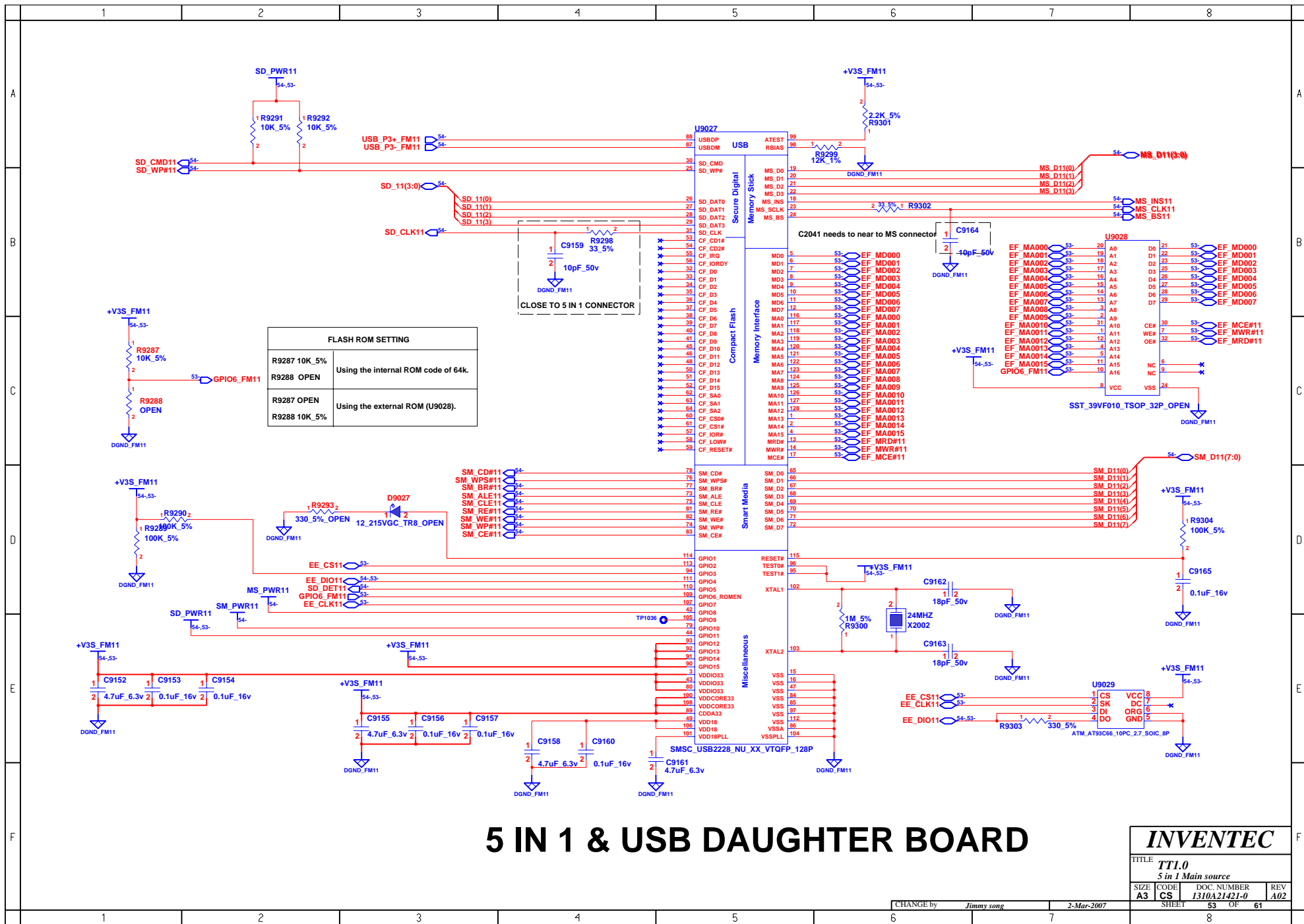

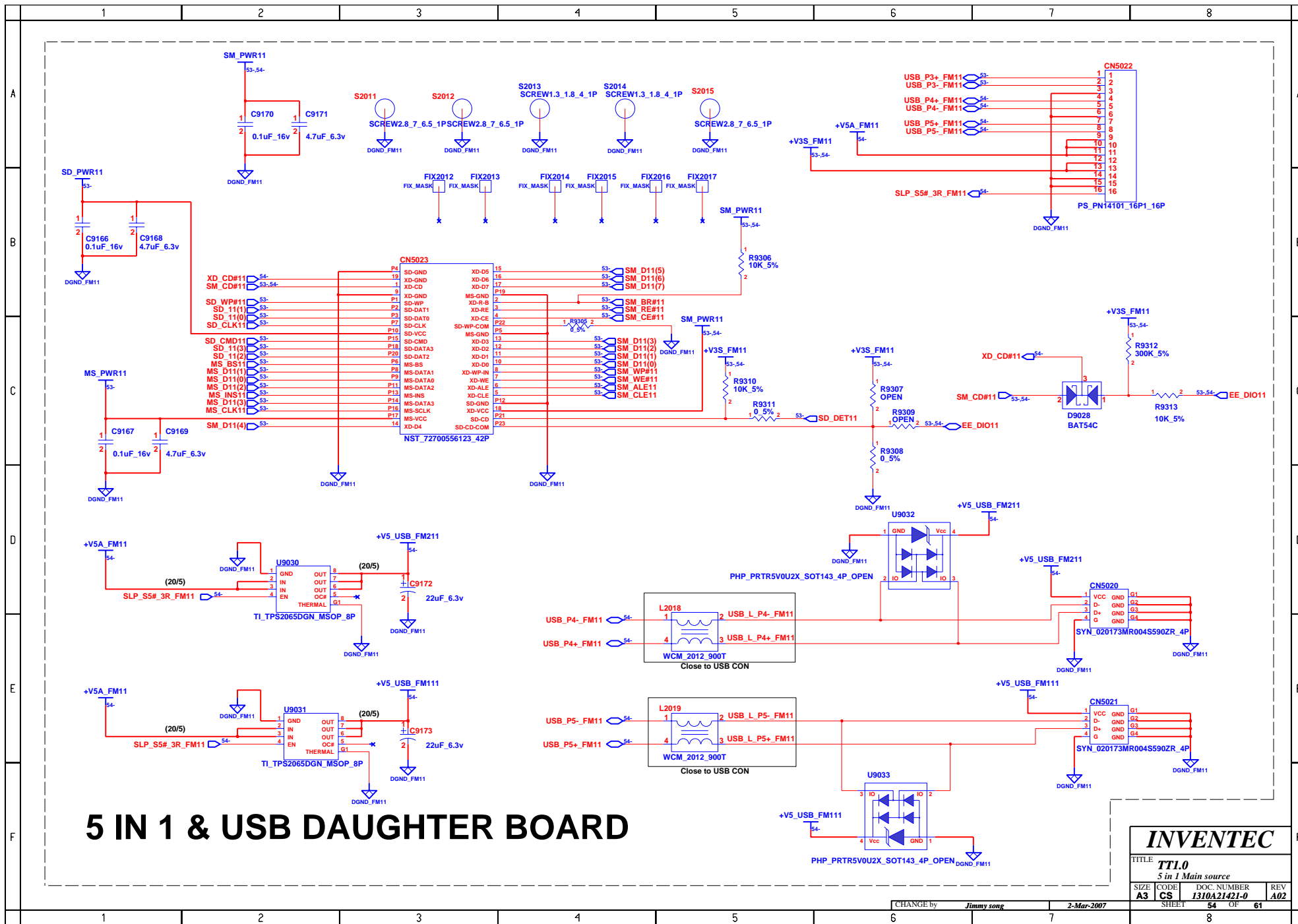

<b>INVENTEC</b>			
TITLE <b>TT1.0</b>			
5 in 1 Main source			
SIZE <b>A3</b>	CODE <b>CS</b>	DOC NUMBER <b>I310A21421-0</b>	REV <b>A02</b>
CHANGE by <i>Jimmy song</i>		2-Mar-2007	
SHEET <b>54</b>		OF <b>61</b>	

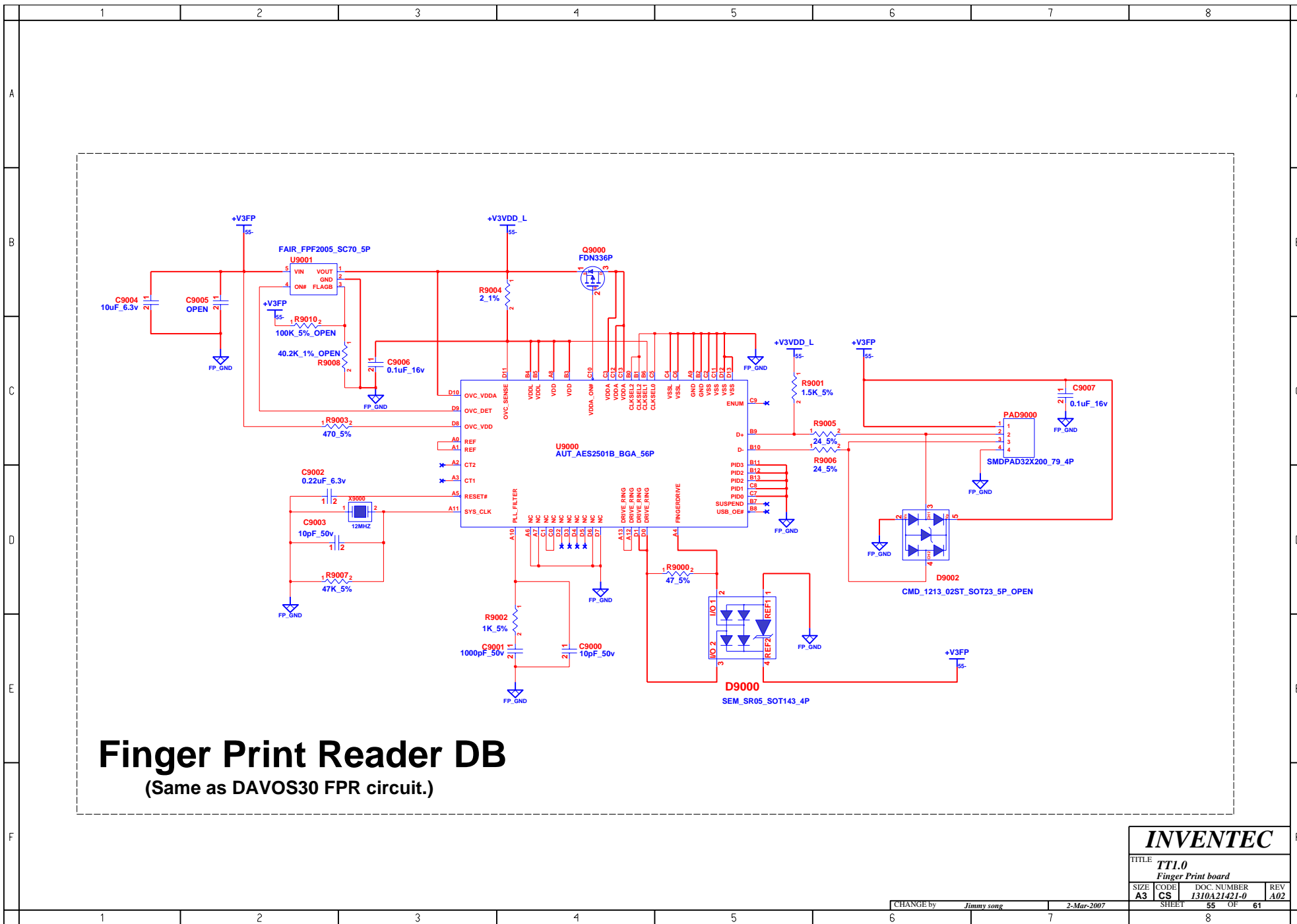

**INVENTEC**

TITLE			
TT1.0			
Finger Print board			
SIZE	CODE	DOC. NUMBER	REV
A3	CS	1310A21421-0	A02
CHANGE by		SHEET	
Jimmy song		55 OF 61	

2-Mar-2007

**BLANK**

<b>INVENTEC</b>			
TITLE <i>TT1.0</i> <i>BLANK</i>			
SIZE <b>A3</b>	CODE <b>CS</b>	DOC. NUMBER <i>1310A21421-0</i>	REV <i>A02</i>
CHANGE by <i>Jimmy song</i>		2-Mar-2007	
SHEET		56	OF 61
		8	

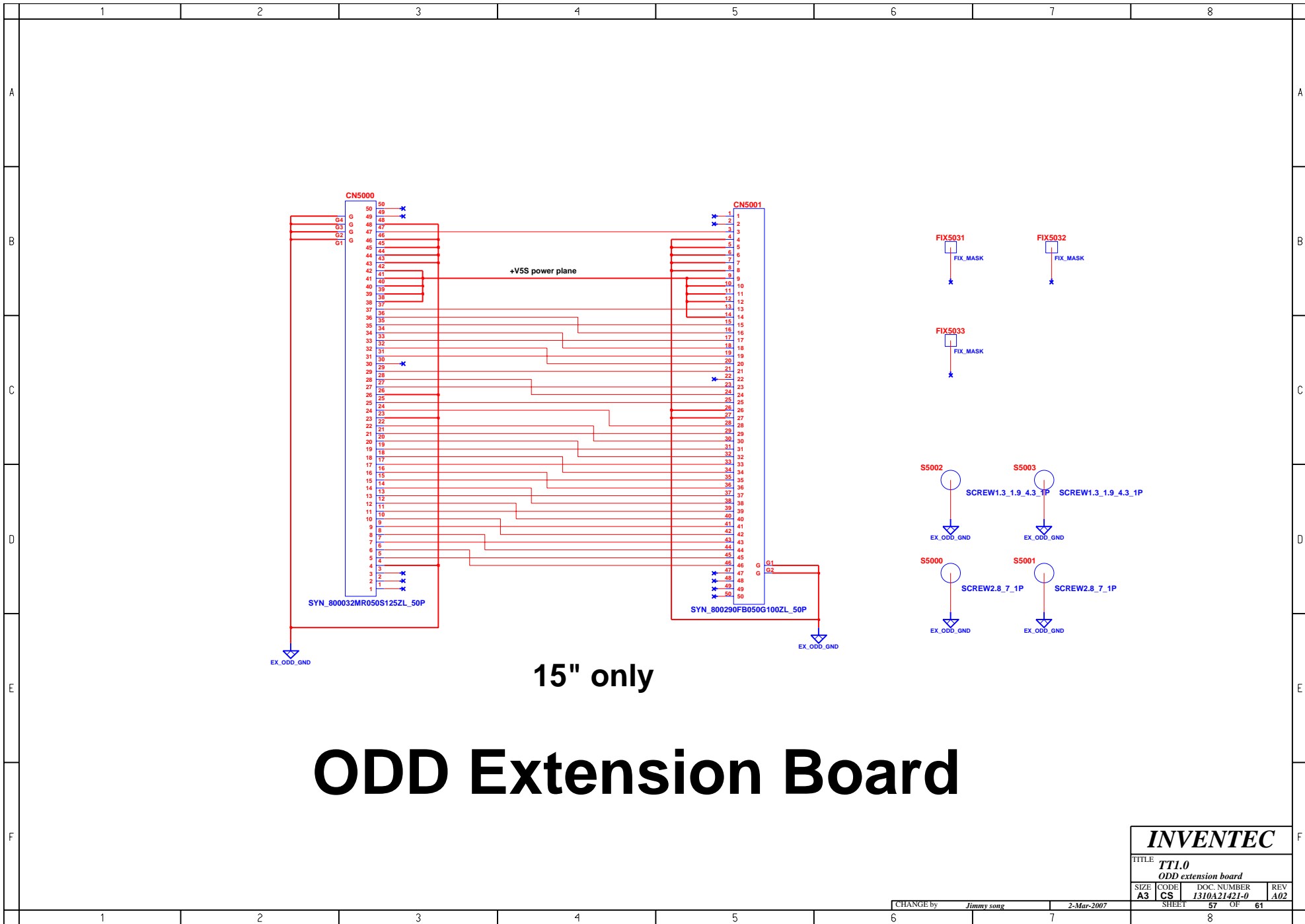

**INVENTEC**

TITLE			
TT1.0			
ODD extension board			
SIZE	CODE	DOC. NUMBER	REV
A3	CS	1310A21421-0	A02

CHANGE by Jimmy song 2-Mar-2007

SHEET 57 OF 61

	FF+WWAN	DF	FF
CN28,C448,C449	Install	uninstall	Install
R53,R54,R55	Install	Install	Install

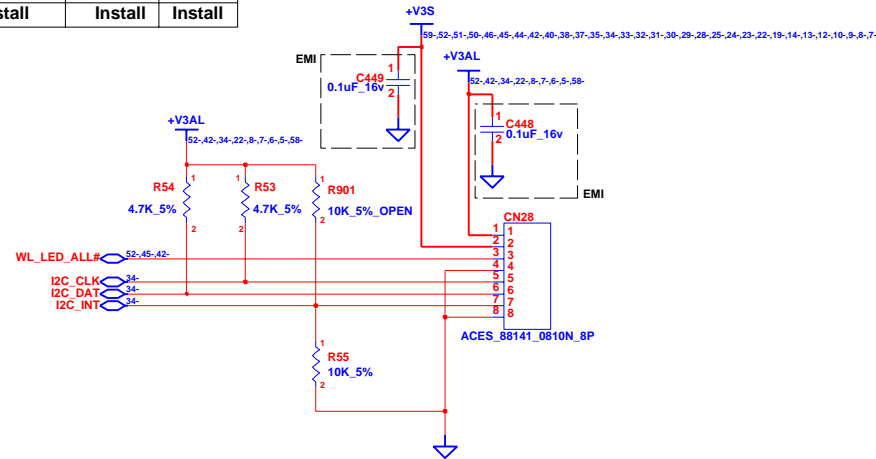

**INVENTEC**

TITLE <i>TT1.0</i>			
SW/B connector			
SIZE <b>A3</b>	CODE <b>CS</b>	DOC. NUMBER <b>1310A21421-0</b>	REV <b>A02</b>
CHANGE by <i>Jimmy song</i>		2-Mar-2007	
SHEET <b>58</b>		OF <b>61</b>	



